

artstyle.international

# ART STYLE

Art & Culture  
International  
Magazine

Volume 10 | Issue 10 | September 2022

## MULTIMODALITY

The Sensually Organized  
Potential of Artistic Works

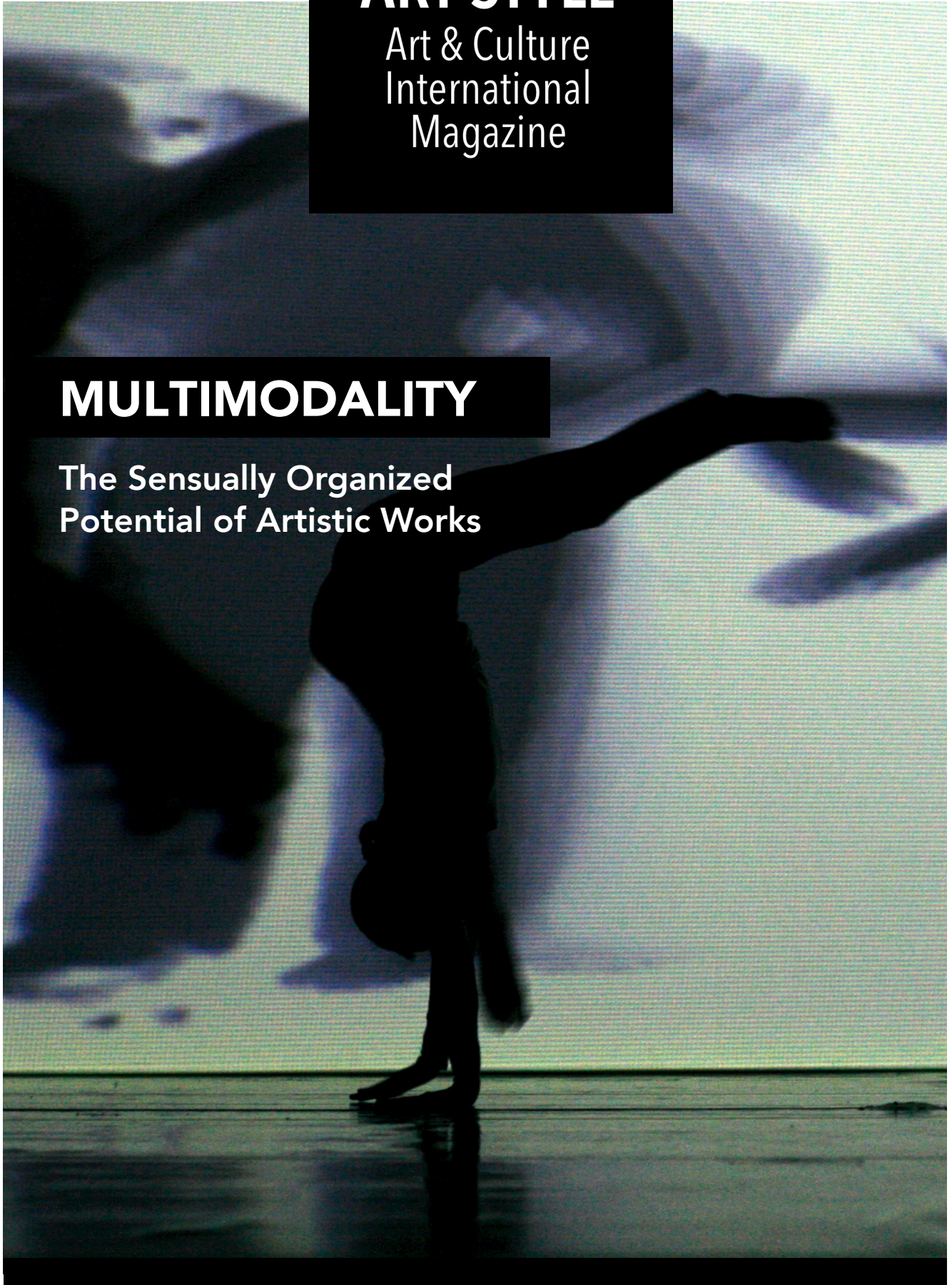

**ART STYLE**  
Art & Culture  
International  
Magazine

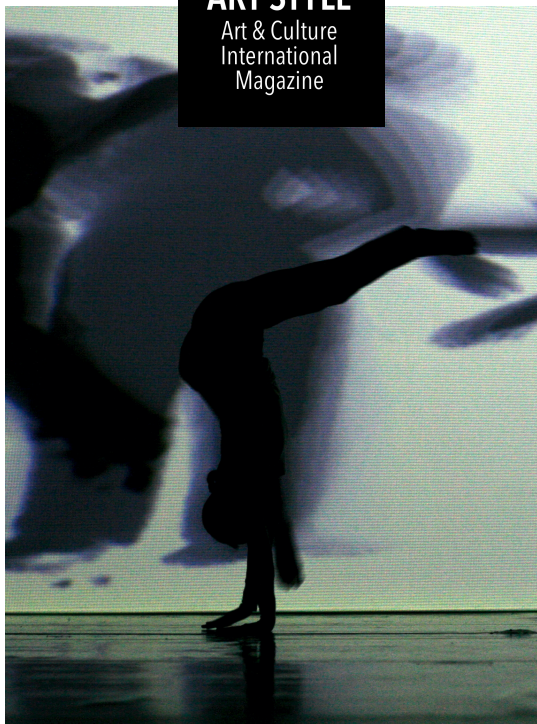

Cover: Theater der Klänge (Germany), *SUITE intermediale*.  
Dancer: Catalina Gomez. Video: Falk Grieffenhagen.  
Photo: Oliver Eltinger 2010.

#### Academic Editors

Editor-in-Chief and Creative Director  
Christiane Wagner

Senior Editor  
Martina Sauer

Associate Editors  
Laurence Larochelle  
Katarina Andjelkovic  
Natasha Marzliak

Collaborators  
Charlotte Thibault  
Denise Meyer  
Jan Schandal  
Marjorie Lambert

#### Art Style | Art & Culture International Magazine

[editorial@artstyle.international](mailto:editorial@artstyle.international)

+1 347 352 8564 New York  
+55 11 3230 6423 São Paulo

The Magazine is a product of Art Style Communication & Editions.  
Founded in 1995, the Art Style Company operates worldwide in the fields  
of design, architecture, communication, arts, aesthetics, and culture.

ISSN 2596-1810 (Online)  
ISSN 2596-1802 (Print)

Theodor Herzi, 49 | 05014 020 Sao Paulo, SP | CNPJ 00.445.976/0001-78  
Christiane Wagner is a registered journalist and editor: MTB 0073952/SP  
© 1995 Art Style Comunicação & Edições / Communication & Editions

**Art Style | Art & Culture International Magazine** is an open access, biannual, and peer-reviewed online magazine that aims to bundle cultural diversity. All values of cultures are shown in their varieties of art. Beyond the importance of the medium, form, and context in which art takes its characteristics, we also consider the significance of socio-cultural and market influence. Thus, there are different forms of visual expression and perception through the media and environment. The images relate to the cultural changes and their time-space significance—the spirit of the time. Hence, it is not only about the image itself and its description but rather its effects on culture, in which reciprocity is involved. For example, a variety of visual narratives—like movies, TV shows, videos, performances, media, digital arts, visual technologies and video game as part of the video's story, communications design, and also, drawing, painting, photography, dance, theater, literature, sculpture, architecture and design—are discussed in their visual significance as well as in synchronization with music in daily interactions. Moreover, this magazine handles images and sounds concerning the meaning in culture due to the influence of ideologies, trends, or functions for informational purposes as forms of communication beyond the significance of art and its issues related to the socio-cultural and political context. However, the significance of art and all kinds of aesthetic experiences represent a transformation for our nature as human beings. In general, questions concerning the meaning of art are frequently linked to the process of perception and imagination. This process can be understood as an aesthetic experience in art, media, and fields such as motion pictures, music, and many other creative works and events that contribute to one's knowledge, opinions, or skills. Accordingly, examining the digital technologies, motion picture, sound recording, broadcasting industries, and its social impact, Art Style Magazine focuses on the myriad meanings of art to become aware of their effects on culture as well as their communication dynamics.



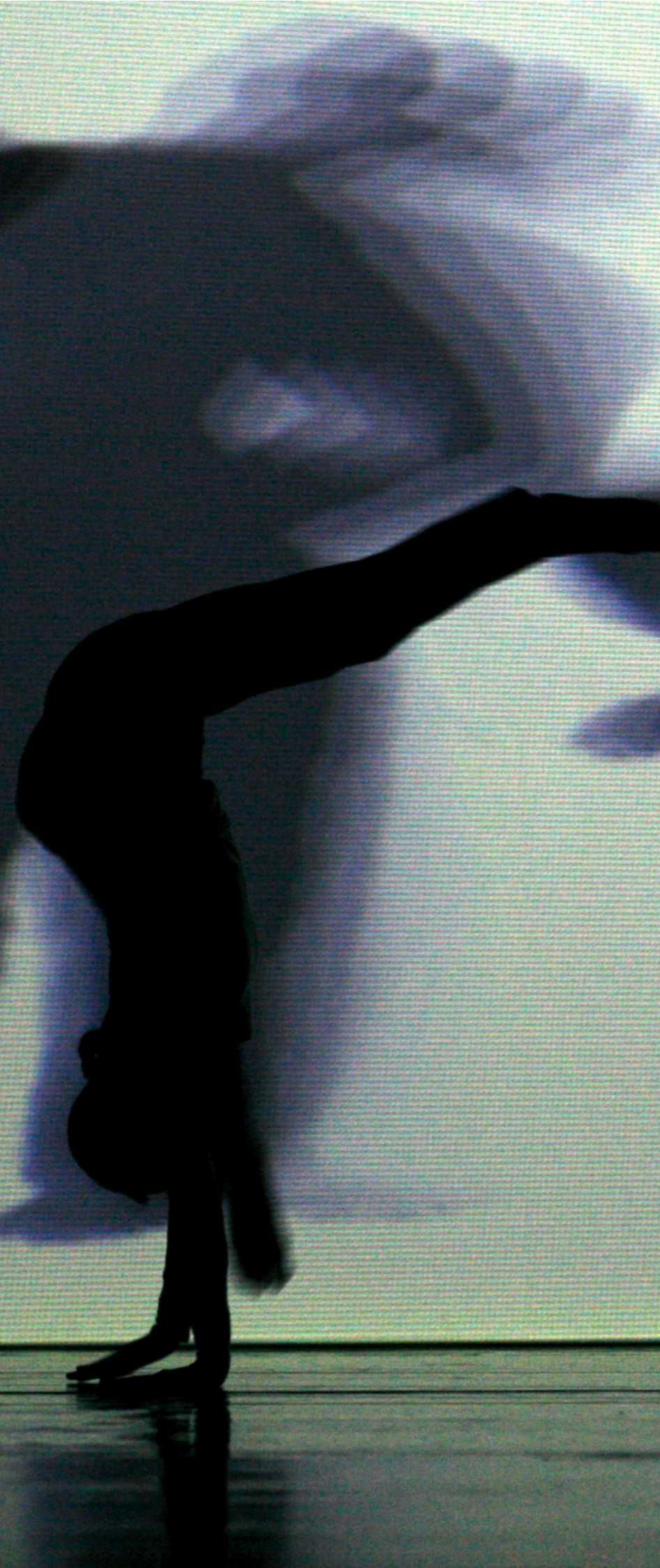



# Content

## Editorial

Christiane Wagner  
Editor-in-Chief and Creative Director

## Introduction

Christiane Wagner  
Editor-in-Chief

Martina Sauer  
Senior Editor

## Essays and Articles

- 11** **From Neuroscience to Art:  
The Role of 'Vitality Forms' in the  
Investigation of Multimodality**  
by Giada Lombardi and Giuseppe Di Cesare
- 25** **Abstract - Affective – Multimodal:  
Interaction between Medium and Perception of Moving  
Images from the Viewpoint of Cassirer's, Langer's and  
Krois' Embodiment Theories**  
by Martina Sauer
- 49** **The Secrets of Plastic Language Revealed:  
Multimodality, Polysemiosis, and Iconicity**  
by Göran Sonesson
- 71** **Making Sense of the Material:  
Multisensory Reader Involvement  
in Contemporary Multimodal Novels**  
by Natalia Igl
- 87** **Art is All: Proust's Life Lessons  
Through Perception and Art**  
by J. Philippe Thompson
- 107** **Philippe Parreno and the Exhibition  
as a Multimodal Aesthetic Experience**  
by Hans Dieter Huber
- 135** **The Performing Human Being  
in a Media Interaction Space:  
Multi- and intermodal productions by the  
Düsseldorf Theater der Klänge (Theatre of Sounds)**  
by Jörg U. Lensing
- 163** **Scientific Committee  
Editorial Board & Information**

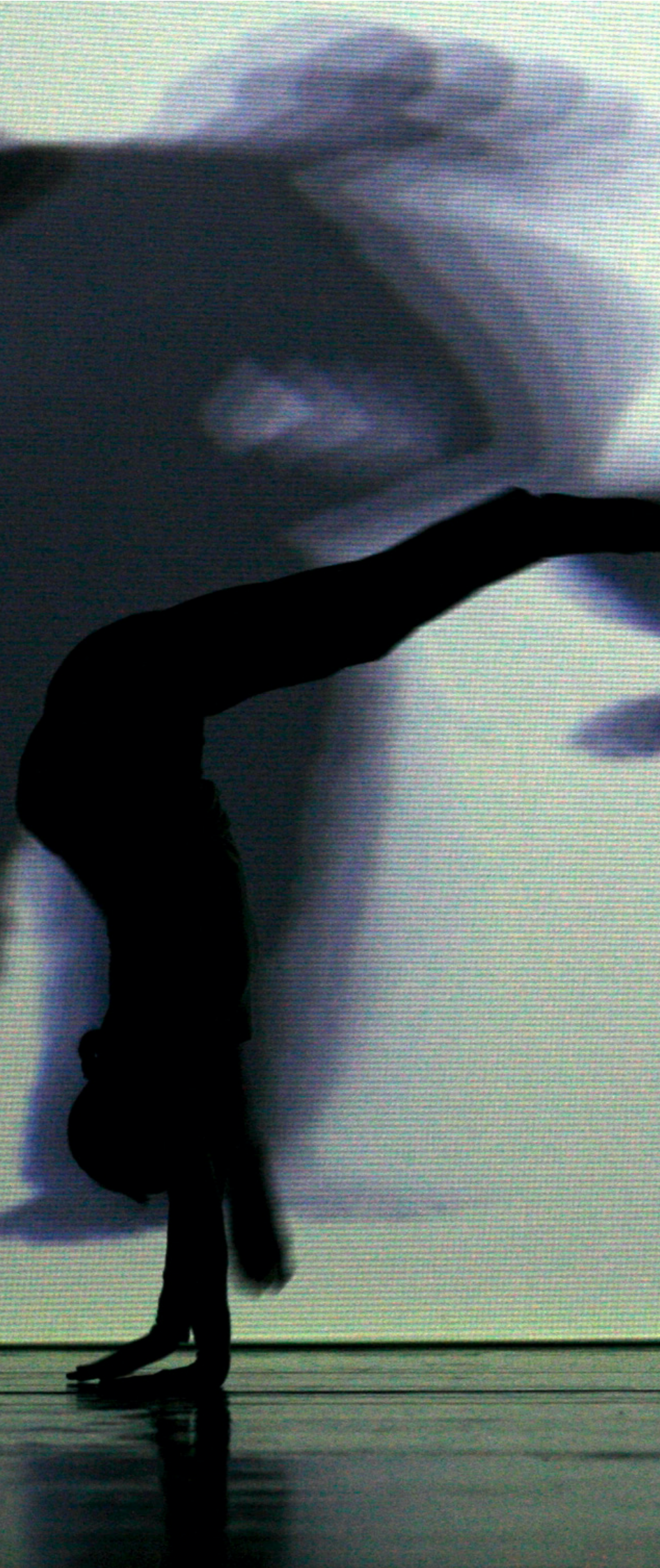



## Editorial

Dear readers,

With great pleasure, we bring to completion another edition of *Art Style, Art & Culture International Magazine*. In our editorial journey, seeking to meet the criteria for academic publications and improve the quality of our publications, many achievements have already taken place and can be checked in our issues. Furthermore, publication opportunities for researchers and academics are always open, and other contributors are also welcome. So *let's stay tuned* to our social networks and news! Moreover, to give continuity to the special issues, we have prepared a series of editions that follow a scheduled plan according to our biannual periodicity. All the information can be found on our webpage, Guest Editors' Guidelines, for those interested in developing a special issue.

Accordingly, each new edition presents a different focus. Recently, given the diversity of themes, the relation between art and science has been highlighted, stimulating discussions about the evolution of knowledge through arts. It has been verified that in the last decades, universities, research institutions, and funding agencies have intensely invested in the relationship between art and science. However, this relationship is not new; it is part of the history of the evolution of knowledge. Furthermore, the connection between science and art is part of logical reasoning. That is, they are guided by creativity, the development of techniques, and the capacity of reflection and abstraction to construct knowledge. So, one of the main characteristics of our editions is to mediate the academic production with interested readers on art and culture in its aesthetic and functional aspects. The aim is to synthesize the relationship between reason and sensitivity to understand the human being and the environment surrounding them. In addition, new methodologies, approaches to the scientific method, and ways of applying digital resources to the interaction between the artistic work and the observer must be considered regarding the amplitude of art and science in the face of cultural diversity.

Thus, in response to this demand, the current issue on *multimodality*, organized by Martina Sauer and myself, addresses the main theoretical currents that seek to understand the arts related to science, grounding them epistemologically, linking the aesthetic and scientific understanding of the historical context that is, to the sociocultural influences in their modes of representation and perception of art. In this sense, a detailed introduction to the theme of this issue is presented hereafter.

Christiane Wagner  
Editor-in-Chief and Creative Director

## Multimodality

### The Sensually Organized Potential of Artistic Works

In research, multimodality is usually seen as closely connected with perception, which is addressed via specific “medialities” of information carriers. From a perspective focused on our perception, however, we respond not only to technical media and their multimodally structured sign systems but also to our bodies’ very own. In this way, the originally materially bound background concept of media can be expanded. Also, sounds and gestures or artifacts performed or realized with the body or the hands (speech, music, gestures, and images), which are not classically considered media, can be included. That is because multimodal communication is also possible through their respective structural conditions or sign systems. Thus, essential for the concept of multimodality, besides the specific addressing of the senses, is the respective mode or dynamic side of processing (communicative) meanings via signs, as Jan Schneider and Hartmut Stöckl (2011) indicated in *Medientheorien und Multimodalität (Media Theories and Multimodality)*.

It is also true (especially for the arts) that their abstract structures—modes—hardly meet the claim of concrete meanings or codes. For example, brushstrokes, different colors, shapes, gestures, and sequences of tones have no concrete meaning. Instead, they prove to be fundamentally open to meaning so that compositions can be created from them that correspond to the producers’ different expressive needs and statements. However, the cognitive processing of the modes by the recipients is also correspondingly open because it depends on their situation, time, and socio-cultural preconditions. If we consider this open, dynamic side of the arts, further questions arise concerning the foundations of aesthetics in sensations (*aisthēsis*). Do the various perceptual stimuli evoked by the modes of the arts also have a communicative function? Are the energetic impulses received through sounds and gestures or colors and shapes communicatively relevant with regard to possible thematic statements of works of the arts? What consequences can be drawn from this in sociocultural terms? Therefore, concrete multimodal analyses are needed in addition to the theoretical proposals indicated here to understand better the possible reaches and communication potentials (affordances) of the arts. For this purpose, this issue welcomed contributions exemplifying both the structural and signification potential of artistic works through multimodal analysis. Particular attention was given to contributions clarifying how the structural features—the modes—of the arts, their perception, and their possible meanings in terms of content are interrelated and how they are to be understood in communicative and, thus, socioculturally relevant terms.

From a neuroscientific point of view, in this issue on multimodality, this approach is addressed by Italian researchers at the Italian Institute of Technology (IIT) in Genoa and Parma, Giuseppe di Cesare and Giada Lombardi. Starting from mirror neuron research, introduced in 1996 by the group of Giacomo Rizzolatti in Parma, they related this approach to art and the thesis of affective perception of forms, as described by the American child psychologist Daniel Stern in 1985. The empirical study suggests the possibility of internalizing the vitality forms transmitted by artistic creation and remapping them in the human motor scheme. Beyond reliving the artist’s action and affective state, this process ensures a complete aesthetic viewer experience. It is forms, degrees of intensity, and temporal patterns—and, thus, multimodally and affectively processed abstract forms—that trigger the experience of art and the world. With this thesis, the German image and cultural scientist and co-editor of the special issue, Martina Sauer, ties in the research tradition of mirror neurons and vitality forms.



She recognizes explicit references to notions of embodiment in the philosophy of Ernst Cassirer, John Krois, and Susanne Langer. Using video art as an example, she shows to what extent the methodical application of these aspects can provide information about the socioculturally shaped self-image of the producer and the viewer. Next, in contrast to the blocking axiom that all meaning is conventional, Göran Sonesson focuses on the formative level or plastic layer. He analyzes it on the basis of theories from French structuralism and German Gestalt psychology. Thus, he assumes that its indeterminate potential for similarity is based on structural oppositions, or more precisely on proportionalities, that is, relationships between two pairs of opposing terms, as he shows by means of Doodles. Their overt meaning becomes significant through the sociocultural setting of labels. Natalia Igl, a German, conducts research at Norwegian institutions in the field of literature, cognition, and emotion. Using the contemporary novel as an example, she discusses its multi-semiotic strategies and foregrounded (medial) materiality to engage readers in multisensory experiences in which they are “present” with the book and not just the story. She highlights the importance of understanding reading as a process that engages the mind as well as the body. Then, we have the contribution of Philippe Thompson examining the narrator’s “aesthetic of a re-rooting in perspective” in *In Search of Lost Time* through Impressionism. Through a structuralist analysis of the codes, the author questions how Proust perceived art in his novel and the functionality of the paintings presented in their symbolic and metaphorical aspects. Thompson decodes the text and highlights the complexity of the established codes of interpretation that, according to “Roland Barthes, in *The Death of the Author*, notes in the case of Marcel Proust’s *In Search of Lost Time* as Proust was visibly concerned with the task of inexorably blurring, by an extreme subtilization, the relationships in the novel.”

In the following, we present the article by Hans Dieter Huber addressing two installations by French artist Philippe Parreno, with discussions and analyses on how the multimodality of perception and action can be transferred to algorithmic or biological systems capable of registering and processing sensory inputs and performing motor controls on the objects on exhibit. These artworks are hyper-objects controlled by various multimodal sensory inputs, algorithmic intelligence, or biological organisms and their motor output. Overall, Huber shows how this type of art exemplifies the multisensory aesthetic experience and “how the choreography of the exhibition functions multimodally.” Finally, to close this special issue, Jörg U. Lensing presents the new research results involving the German Düsseldorf Theater der Klänge, of which he is the artistic director. The Theater der Klänge has been working on multimodal, and especially intermodal, manifestations—form, movement, sound design, and light as dynamic concentrations of action—following the guidelines of Bauhaus master Laszlo Moholy-Nagy from 1925 for a theater of the future, with a total of nine intermediate productions for 35 years. The article’s primary focus is on the different approaches to the sensory stages selected and developed based on the question about the meaning of such action and the definition of the performances on stage, besides taking us to the legacy left by the Bauhaus.

Christiane Wagner  
Editor-in-Chief

Martina Sauer  
Senior Editor





# From Neuroscience to Art The Role of “Vitality Forms” in the Investigation of Multimodality

Giada Lombardi and Giuseppe Di Cesare

## Abstract

By observing how actions are performed or by listening to how words are pronounced, people can understand the affective state of others. For example, someone can perform a hand gesture vigorously or kindly or can use a pleasant or unpleasant tone of voice. These fundamental aspects of social interactions, named “vitality forms” by Daniel Stern, enable the receiver and bystanders to understand if the attitude of the agent is negative or positive. Several fMRI studies have investigated the neural correlates of these forms of communication, showing that the dorso-central insula is selectively involved in the processing of vitality forms, regardless the modality in which they are conveyed. In addition to multimodal properties, the dorso-central insula is endowed with a mirror mechanism which, differently from the original one discovered in the parietal and frontal areas, specific for the action goal understanding, might allow us to express our own mood and to understand those of others. Besides social interactions, the mirror mechanism located in the insula plays a crucial role in other aspects of human life. One is the aesthetic experience. In this regard, many studies have proposed that particular artist’s creative gestures, like brushstrokes or cuts on the canvas, are the visible traces of goal-directed movements and they should be capable of activating motor areas in the observers’ brain. More interestingly, if we associate the same idea to the mirror mechanism of the insula, some properties of the artwork would be processed in the dorso-central insula as results of specific vitality forms. This fascinating hypothesis suggests the possibility of internalizing the vitality forms transmitted by the artistic creation and remapping them in our motor scheme. This would allow not only to relive the artist’s action but also his/her affective state, ensuring a complete aesthetic experience.

## Introduction

From birth humans interact with the world: even before learning to speak, infants can communicate their needs and as soon as they learn how to perform simple actions, such as reaching or transporting objects, they immediately start to understand the consequences of others performing the same action. This natural and not necessarily verbal communication is something that characterizes social interactions also in adults. Indeed, humans show a natural ability at interacting with each other, producing behaviors that go beyond conscious control. To better understand this point, let's think about our everyday life: we automatically and unconsciously express our internal states through gestures, sounds and touches, which assume different properties depending on the mood we have in that moment. At the same time, we understand if others have a positive or negative attitude towards us, by observing their gestures or by listening to their voices. Indeed, one can pick up a glass resolutely or delicately, just as one can shake a hand coldly or warmly. A caress can be kind or rushed and also the tone of voice can be gentle or rude. These subtle aspects of social communication have been named *vitality forms* (Stern 2010). If research has always focused on the goal ("what") of actions, vitality forms represent the style, the form, the "how" and thus, in their absence, all social interactions will be devoid of any affective colour (Di Cesare, Gerbella and Rizzolatti 2020). In the last years of research, several fMRI studies have investigated the neural correlates of these forms of communication, showing that the dorso-central insula (DCI) is selectively active during the perception and expression of different vitality forms conveyed through actions, sounds and touches. In the first section of this review, we explain the multimodal role of the dorso-central insula in the processing of vitality forms, by presenting fMRI data obtained by our research group. Starting from these findings, in the second section we describe a mirror mechanism located in the dorso-central insula, which allows us to express our own vitality forms and to understand those expressed by others. Finally, in the third section, we discuss the fundamental role that this mirror mechanism could cover during the aesthetic experience.

## The Dorso Central Insula: A Multimodal Key Node for Vitality Forms Processing

The first evidence for the localization of neural correlates specific for vitality forms was obtained in a fMRI study performed by Parma team in collaboration with Daniel Stern (Di Cesare et al. 2013). In this study participants were presented with video-clips showing two actors (a male and a female), sitting at a table facing each other and performing transitive and intransitive actions (Figure 1AB), each performed with two different vitality forms (gentle or rude). Participants performed two tasks. In the “what” task, they were required to pay attention to the aims of the actions observed and decide whether the two actions were the same or different, regardless of their vitality form. On contrary, in the “how” task, they had to focus on the action vitality forms and decide whether the vitality forms were the same or different in the two consecutive videos, regardless of the type of action performed. In both tasks, activations were found in the parieto-frontal circuit, typically involved in the observation and execution of actions (Figure 1C), but the most relevant result derived from the contrast “how” vs “what”, which revealed a specific activation of the dorso-central insula (Figure 1D). The question that came immediately after was: what happens when an action conveying vitality forms is imagined or executed in first person and not just observed? To address this issue, in a subsequent fMRI study (Di Cesare et al. 2015) participants were required to perform three different tasks: observation (OBS), imagination (IMA) and execution (EXE). In the observation task, they observed video clips showing the right arm of an actor performing actions toward another actor, with either a gentle or a rude vitality form. In the imagination task, participants had to imagine themselves performing the actions seen during the observation task, again with gentle or rude vitality forms. In the execution task, participants moved a packet of crackers located on a plane lying on their chest as if offering them to another person, with a gentle or rude vitality form. Finally, in a control condition, the participants were requested to observe video clips showing the hand of an actor placing a small ball in a box, imagine themselves performing the same action, or finally, place a small ball inside one of two boxes placed inside the scanner. The main result of this study was the demonstration that, besides the observation, also the execution and the imagination of actions performed with a vitality form, relative to control actions, determines a specific activation of the dorso-central insula.

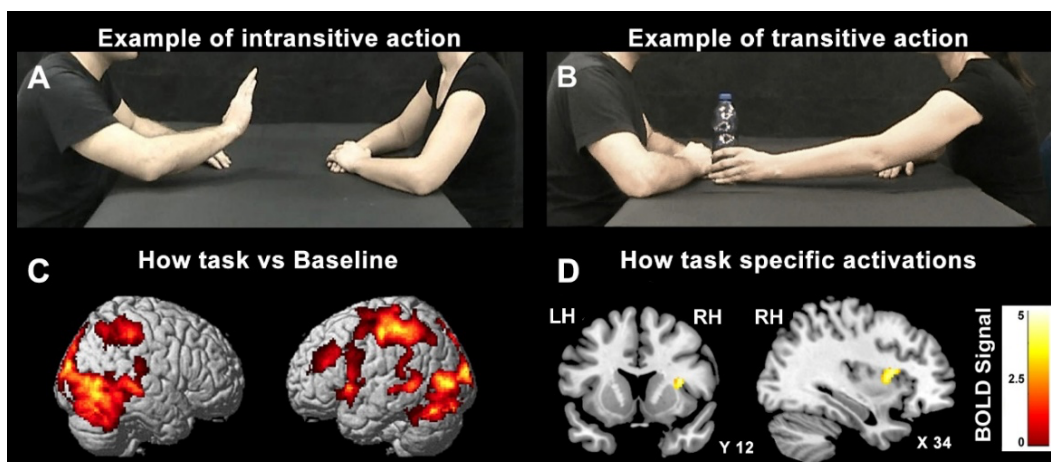

Figure 1. Example of video clips observed by participants showing an intransitive action (stop gesture) (A) or a transitive action (passing a bottle) (B). Brain activations resulting from the contrast how task vs baseline condition (fixation cross) (C). Brain activations specific for vitality forms processing (dorso-central insula) resulting from the contrast how task vs what task. Figure adapted by Di Cesare et al. 2013.

Vitality forms can be conveyed, not only through gestures and actions, but also through verbal communication. In this respect, as stressed by Stern (1985), listening to words pronounced with different vitality forms plays a crucial role in the attunement between mother and child. In particular, infants manifest an intense interest in the prosodic intonation of maternal talk, and they try to synchronize their expressions with those of the mother. Moreover, during social interactions words conveying vitality forms enable the speaker to communicate his or her internal state and allow the listener to understand the speaker's mood. An interesting question to clarify is whether the dorso-central insula, which is involved in the processing of action vitality forms, is also involved in the encoding of speech vitality forms. For this purpose, in a fMRI study conducted by Di Cesare et al. (2016) participants were presented with audio stimuli consisting of four Italian action verbs (*dammi*: give, *prendi*: take, *tocca*: touch, *strappa*: tear) pronounced by a male actor and a female actress, using two different vitality forms (rude and gentle). Additionally, for each verb, two audio stimuli controls were presented: a robot voice, which pronounced the same verbs maintaining the meaning but not conveying a vitality form and a scrambled version of the four verbs, which maintained the physical properties (pitch and amplitude) of the verbal stimuli but did not convey any meaning. The direct contrasts of vitality forms vs. robot and vitality forms vs. scrambled condition showed, in all cases, a significant activation of the left dorso-central insula (Figure 2).



Interestingly, in a subsequent fMRI study (Di Cesare et al. 2017), the same research group showed that the dorso-central insula involved in the perception of speech vitality forms becomes also active during the imagery of action verbs internally generated with different vitality forms.

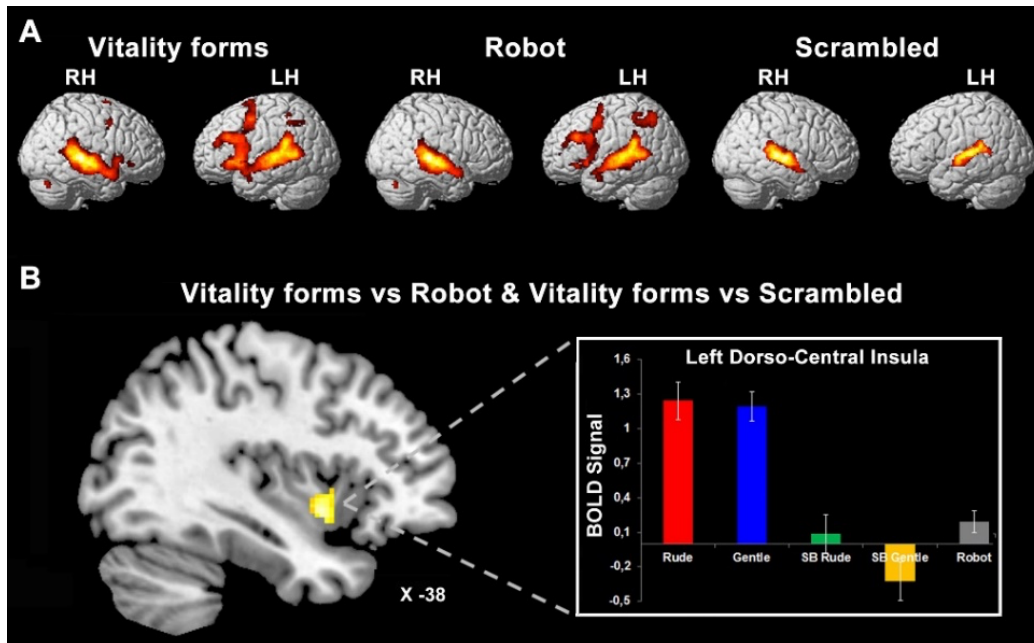

Figure 2. Brain activations obtained in the hearing of three different types of stimuli (vitality forms, robot, scrambled) (A). Specific activation of the left dorso-central insula resulting from the direct contrasts vitality forms vs robot and vitality forms vs scrambled (B, left side). BOLD signal change in the left dorso-central insula (x-38, y 6, z-6) in the vitality forms, robot and scrambled conditions (B, right side). Figure adapted from Di Cesare et al. 2016.

Now, let's think what happens to us when we hear a family member who returns at home after a long day. It's not just by observing the way he walks towards us or listening to his tone of voice that we intuit his state of mind, but it is also through the way he closes the door. From the sound that accompanies this gesture, we understand if he is energetic, tired, calm or nervous. This is a simple example to say that every action performed with a certain vitality form produces a sound characteristic that tells us if the attitude of the agent is positive or negative. Starting from this interesting suggestion, in a recent fMRI study (Di Cesare et al. 2019) participants were presented with five sounds (Figure 3A) coming from daily actions (e.g., stir the coffee, knock the door). In a condition, sounds were characterized by rude or gentle vitality forms and in another condition (control) the vitality form was masked. Results showed that listening to sounds from actions produces an activation of the parieto-frontal circuit, involved in the execution of the same actions and, once again, the activation of LH of the dorso-central sector of the insula is present only in the condition with vitality (Figure 3 B2).

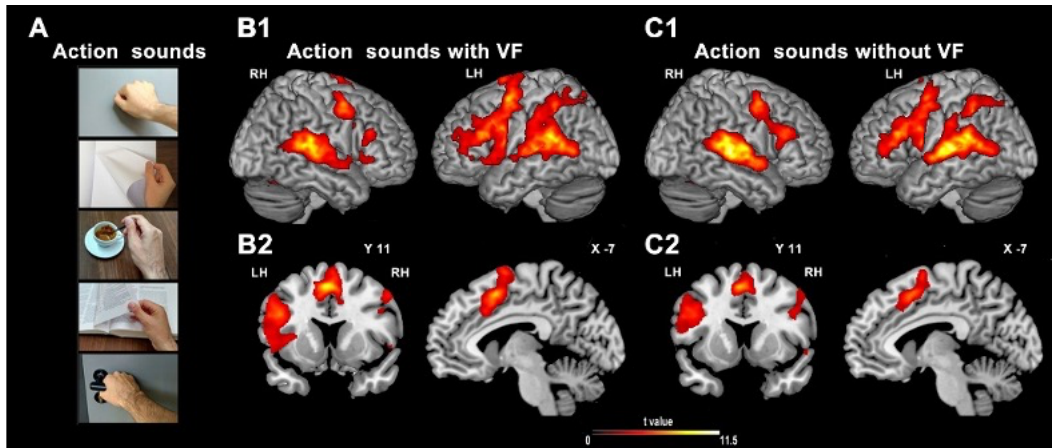

Figure 3. Stimuli consisted in five action sounds (A). Brain activations resulting from the hearing of actions sounds with (B1) and without (C1) vitality forms (VF) vs baseline. Brain sections showing the activation of the insula and the cingulate cortex obtained in the vitality (B2) and control (C2) conditions vs baseline. Figure adapted from Di Cesare et al. 2019.

Recently, Rizzolatti et al. (2021) showed that, besides actions, speech and sounds, vitality forms can be also expressed through tactile modality. The handshake, for example, is a common greeting behavior which conveys information about the affective state and the personality of an individual. Indeed, some handshakes may reveal friendliness and sociability, while others may reveal shyness and introversion. Moreover, a gentle or aggressive handshake may allow the receiver to understand whether the agent is a kind or a rude person. In order to assess the neural correlates of tactile vitality forms a fMRI experiment consisting of three situations was carried out. In the first situation (Figure 4A), the experimenter shook with his right hand the right hand of the participant, while the participant observed video clips showing dynamically facial expression (angry, neutral and happy). The handshake (HS) was performed in an aggressive, neutral, or gentle way and was congruent with the expression conveyed by the facial expression (FE) (e.g. gentle handshake and happy face, aggressive handshake and angry face). In the second situation, participants were presented with the same facial expressions, but did not receive a handshake. Finally, in the third situation, participants received only a handshake (aggressive, gentle or neutral), without the presentation of facial stimuli. Results showed that handshakes conveying tactile vitality forms produced, relative to control, a strong activation of the dorso-central insula and of the middle cingulate cortex (Figure 4B).

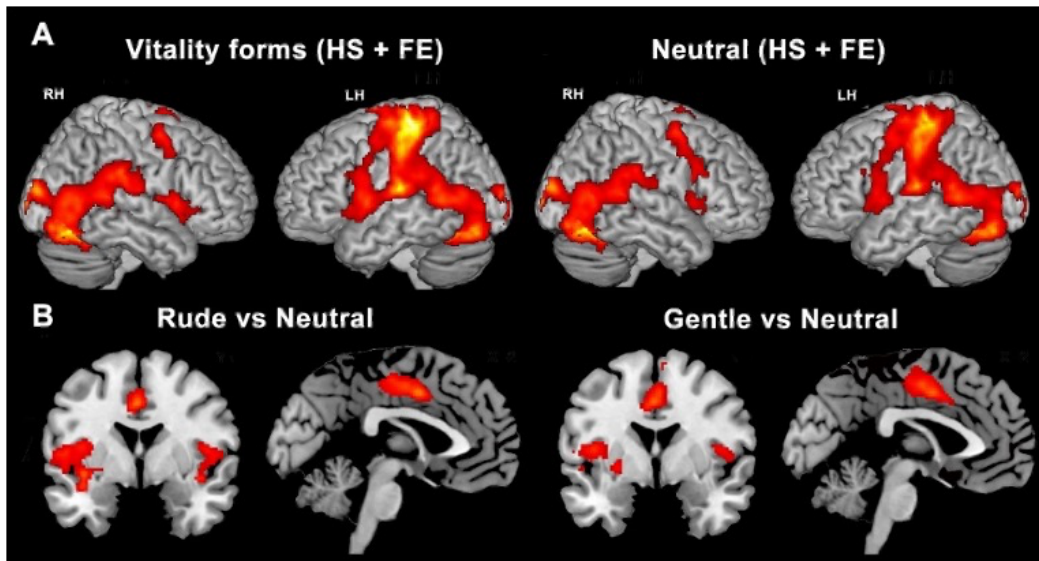

Figure 4. Brain activations resulting from the first situation (handshake HS + facial expression FE) during the vitality forms (rude and gentle) (A) and neutral (control) conditions vs baseline (A). Brain sections showing the activations of the insular and cingulate cortices obtained in situation 1 (HS + FE) for the contrasts rude vs neutral and gentle vs neutral (B). Figure adapted from Rizzolatti et al. 2021.

## A Mirror Mechanism for Vitality Forms Encoding in the Dorso Central Insula

The results reviewed so far indicate that the dorso-central insula (DCI) is the key node for the processing of vitality forms, conveyed through actions, sounds and touches and thus it has multimodal properties. Most interestingly, the presence of a specific activation during both perception and expression of vitality forms suggests that this brain area is endowed with mirror properties. The mirror mechanism was first discovered in a class of motor neurons in the ventral premotor cortex of the macaque monkey and subsequently found in other species including humans (Rizzolatti and Craighero 2004). The property of these neurons is to discharge both when someone performs a given motor act and when someone observes another individual performing a motor act with a similar goal. Differently from the mirror mechanism located in the parieto-frontal circuit, the mirror mechanism of the insula allows us to express our own vitality forms and at the same time to understand those expressed by others (Di Cesare et al. 2021). This means that, as sensory representations of the action goal are transformed into motor representations of the same goal in the parieto-frontal circuits (original mirror mechanism), a similar mirror transformation also occurs in the dorso central insula, transforming the sensory representation of perceived vitality forms into

their motor or visceromotor representation. This finding fits with the general organization of the insula in humans (Di Cesare, Gerbella, and Rizzolatti 2020). According to Kurth and colleagues (2010) the human's insula is composed by four main different sectors: the sensorimotor, the socio-emotional, the olfactory-gustatory and the cognitive domains. Craig (2002) described the insula as a sensory "interoceptive cortex" that integrates homeostatic, visceral, nociceptive, and somatosensory inputs. Based on these sensory inputs, the insula is considered to generate a representation of the internal state of the body in which somatic and visceral components are integrated and ultimately give rise to a "feeling of the body" (Singer et al. 2004). Moreover, the dorso-central insula is anatomically connected with the three main nodes of the parieto-frontal circuit (Inferior Parietal Lobe, Ventral Premotor Cortex and area 46) involved in reaching/grasping arm movement (Di Cesare, Gerbella and Rizzolatti 2020). Thus, these data suggest that during vitality forms expression the DCI plays a role in transforming information regarding the internal state into the affective component of an action, while during vitality forms perception it allows the receiver to understand the affective state of the agent.

## How Does the Aesthetic Experience Relate to the Mirror Mechanism?

The neuroscientific investigation of the relationship between art and brain started to emerge in works by Changeux (1994) and Zeki (1999) in the 1990s. Such studies emphasized the specific correspondence between the cortical organization of the visual nervous system and the visual attributes that artists use to express their art. After the discovery of mirror neurons and thus the existence of visual and motor responses embedded in the same brain structures, vision started to represent a multimodal process that implies the activation of cerebral circuits not only "visual," but also sensory-motor, visceromotor and affective (such as the insula). According to Gallese, the mirror mechanism (which in the previous section we have associated also to vitality forms processing) represents one of the multiple neural expressions of a basic functional mechanism of our brain-body system, called "embodied simulation" (Gallese and Sinigaglia 2011). By means of embodied simulation, the same brain structures involved in performing vitality forms, for example, are also active when such vitality forms are recognized in others and, referring to the aesthetic experience, observed in a work of art. In this regard, the multimodality of the insula, deputed to vitality forms encoding,



matches with the multimodality of art. Indeed, as during everyday life we expressed and perceived vitality forms through actions, speech, sounds and touches (multimodality of vitality forms), the artist leaves us traces of his/her vitality forms through lines, colors, materials, shapes (multimodality of art) and we immediately catch these affective states thanks to our mirror neurons (multimodality of the insula specific for vitality forms). It was recently proposed that some artist's creative gestures, like brushstrokes or cuts on the canvas, are the visible traces of goal-directed movements and they should be capable of activating the relevant motor areas in the observers' brain (Freedberg and Gallese 2007). A study conducted by Umiltà et al. (2012) aimed to investigate whether the visual perception of static images from abstract art works might be associated with specific cortical motor activation in their perceivers. In particular, using high-density electroencephalography (EEG), they measured the intensity of mu rhythm suppression from the cortical central areas during the observation of high-resolution digitized images of abstract works by Lucio Fontana (Figure 5A) and of graphically modified versions of them (Figure 5B). Results showed that only the original artworks evoked cortical motor activation, as exemplified by mu rhythm suppression recorded from two selected clusters of 8 electrodes in each hemisphere located around standard C3 and C4 sites. The same clusters were used in previous studies showing mu rhythm suppression during the observation of hand motor acts (Muthukumaraswamy and Johnson 2004).

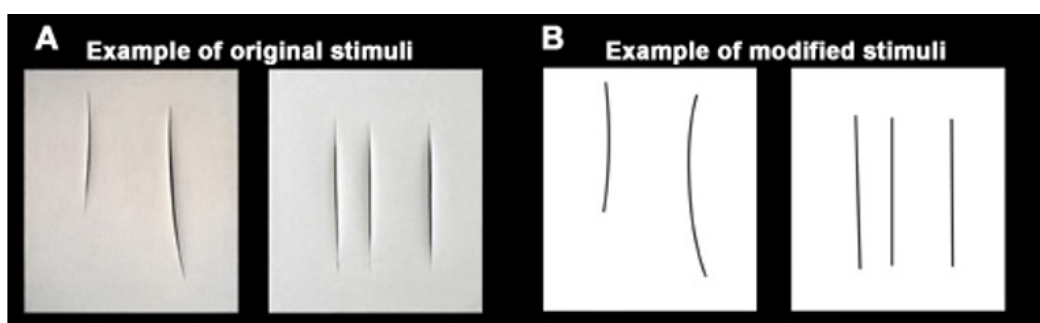

Figure 5. Example of stimuli presented to participants: original art works by Lucio Fontana (A) and modified versions of them (B). Figure adapted by Umiltà et al. 2012.

Following a similar approach, in another study conducted by Sbriscia-Fioretti et al. (2013), participants were presented with two categories of stimuli: Paintings and Modified stimuli. Paintings stimuli (Figure 6A) consisted of digital images of black and white brushstrokes by Franz Kline, an artist belonging to the Abstract Expressionism. Modified stimuli (Figure 6B) were instead obtained by removing

the dynamic components of the original Paintings and by replacing them with graphic dense black stripes of a similar thickness and length, with the intent of removing the visible consequences of the artist's gesture. The results of the ERP mean amplitude analyses showed that the observation of Paintings produced a significantly greater cortical activation compared to the observation of Modified stimuli.

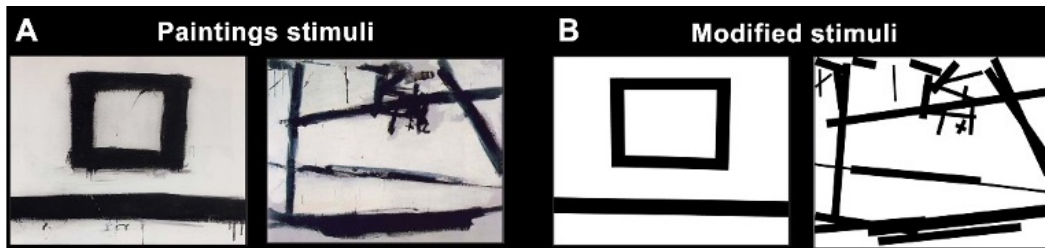

Figure 6. Example of stimuli presented to participants: original art works by Franz Kline (Paintings stimuli) (A) and modified versions of them (Modified stimuli) (B).  
Figure adapted from Sbriscia-Fioretti et al. 2013.

All these findings support the hypothesis postulating the role of embodied simulation of artist's gestures in the perception of his/her works of art. In particular, the observation of the cut on canvas and brushstrokes activates the motor representation of the same artistic gestures in the brain. On contrary, the modified versions of works do not elicit this mechanism because they are not processed as consequence of someone's gesture. If we reformulated this idea in vitality forms terms, the observation of the original artworks would activate the insular mirror mechanism and thus specific properties such as the depth of Fontana's cuts or the width and thickness of Kline's brushstrokes would be processed in the dorso-central insula as results of specific vitality forms. For example, deep cuts or dense and wide brushstrokes could be the result of rude gestures performed by the artist. This suggestion opens an interesting perspective for future works, with the final aim to create a deeper connection between art and neuroscience. In this regard, we conclude presenting an abstract artwork found in the web: "Throw Ups" by Niels "Shoe" Meulma. The complete work is shown in figure 7A. If we observe figure 7B, showing the final artistic product, our scientific questions are: does our dorso-central insula is active? Are certain properties of the picture encoded in our brain as result of specific vitality forms? Are we able to understand the action (Figure 7C) that has produced this work and process its dynamic properties? Future studies need to be carried out in order to address these issues.

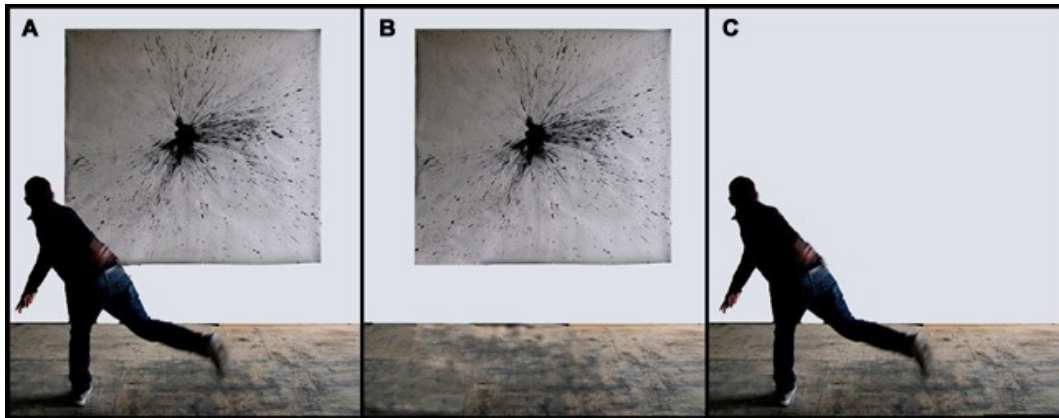

Figure 7: Complete and original artwork "Throw ups" by Niels "Shoe" Meulma (A). Modified version of Figure7A representing only the abstract work (B). Modified version of Figure7A representing only the human's gesture.

## Conclusions

To conclude, in the present essay we have tried to highlight the crucial role that vitality forms play in our lives, modulating the human behavior in a continuous manner. These aspects of social communication are unfortunately still little known and studied but, as deeply described, several fMRI experiments conducted by our research group have even shown the presence of a brain region selectively involved in their processing: the dorso-central insula. This insular sector is characterized by a mirror mechanism which makes the expression and the understanding of vitality forms possible. In the final section, we described the importance of this mechanism during the aesthetic experience, showing important correlations between the observation of original abstract artworks and cortical activations typically involved in action goal understanding. The idea we described in the final part is the possibility to investigate if the dorso-central insula is also involved in the encoding of specific details of the artwork as results of an artistic gesture endowed with vitality forms. Stern himself had already discerned a connection with the perception of art, so that the artist's style can be seen as a pendant to the spontaneous behavior in the field of 'vitality affects' (Sauer 2019). With this in mind, for the future we addressed the interesting perspective to extend the neuroscientific study of vitality forms to art, a discipline traditionally dealt with exclusively within the camp of the humanities.

## Authors Biography

**Giada Lombardi** (Genova, 1997) obtained her Bachelor's degree in Biomedical Engineering at the University of Genova, Italy (DIBRIS) and specialized at the same University in Neuroengineering (110 cum laude). She carried out her Master thesis at the Italian Institute of Technology (IIT) of Genova, where she discovered Giuseppe Di Cesare's project on vitality forms. She continued her research applying for a PhD on the same research theme. From November 2020, she is a PhD student, supervised by Dr. Giuseppe Di Cesare and Dr.ssa Alessandra Sciutti, at the IIT of Genova (CONTACT lab). Thanks to a collaboration with the Department of Neuroscience at the University of Parma, Italy, she is improving her skills with neuroimaging techniques such as fMRI and DTI.

**Giuseppe Di Cesare** (Matera, 1983) graduated in Biology at the University of Rome and obtained the PhD in Neuroscience from the University of Parma, Italy. During his PhD he improved fMRI skills applying this technique to several studies. Lead author of "Vitality Project," aiming to study the neural basis of these forms of communication by using the fMRI technique, expanding this study to autism and robotics. Since August 2019, he is working at the Italian Institute of Technology (IIT) in Genova, Italy (CONTACT lab) where he is carrying out experiments on human-robot interactions involving fMRI and kinematics data collection as part of the ERC starting grant awarded to Dr.ssa Alessandra Sciutti (G.A: 804388). ORCID: 0000-0002-3666-8059

## Bibliography

- Changeux, Jean Pierre. "Art and neuroscience." *Leonardo* 27 (1994): 189–201.
- Craig, Arthur D. "How do you feel? Interoception: the sense of the physiological condition of the body." *Nat Rev Neurosci.* 3 (2002): 655–66.
- Di Cesare, Giuseppe et al. "The neural correlates of 'vitality form' recognition: an fMRI study." *Soc. Cognit. Affect. Neurosci.* 9 (2013): 951–60.
- . "Mirroring the social aspects of speech and actions: the role of the insula." *Cereb Cortex* 28, no. 4 (2018): 1348–1357.
- . "Understanding the internal states of others by listening to action verbs." *Neuropsychologia* 89 (2016): 172–179.
- . "Understanding the attitude of others by hearing action sounds: the role of the insula." *Sci Rep* 9, no. 1 (2019): 14430.
- . "The middle cingulate cortex and dorso-central insula: A mirror circuit encoding observation and execution of vitality forms." *Proc Natl Acad Sci U S A.* 118, no. 44 (2021): e2111358118.
- Di Cesare, Giuseppe, Marzio Gerbella, and Giacomo Rizzolatti. "The neural bases of vitality forms." *Natl Sci Rev* 7, no. 1 (2020): 202–213
- Freedberg, David, and Vittorio Gallese. "Motion, Emotion and Empathy in Aesthetic Experience." *Trends Cogn Sci* 11 (2007): 197–203.
- Gallese, Vittorio, and Corrado Sinigaglia. "What is so special with Embodied Simulation?" *Trends Cogn Sci* 15, no. 11 (2011): 512–19.



- Kurth, Florian et al. "A link between the systems: functional differentiation and integration within the human insula revealed by meta-analysis." *Brain Struct Funct.* 214 (2010): 519–34.
- Muthukumaraswamy, Suresh D., and Blake Johnson. "Primary motor cortex activation during action observation revealed by wavelet analysis of the EEG." *Clin. Neurophysiol.* 115 (2004): 1760–66.
- Rizzolatti, Giacomo, and Laila Craighero. "The mirror-neuron system." *Annual Review Neuroscience* 27 (2004): 169–92.
- Rizzolatti, Giacomo et al. "The neural bases of tactile vitality forms and their modulation by social context." *Sci Rep* 11 (2021): 9095.
- Sauer, Martina. "Framing Emotional Perception: Affect and Effect of Aesthetic Experience, or Extensions of Aesthetic Theory Towards Semiotics." *Art Style, Art & Culture International Magazine* 4, no. 4 (2019): 73–87.
- Sbriscia-Fioretti, Beatrice et al. "ERP Modulation during Observation of Abstract Paintings by Franz Kline." *PLoS ONE* 8, no. 10 (2013): e75241.
- Singer, Tania et al. "Empathy for pain involves the affective but not sensory components of pain." *Science* 303 (2004): 1157–62.
- Stern, Daniel N. *Forms of vitality exploring dynamic experience in psychology, arts, psychotherapy, and development.* New York: Oxford University Press, 2010.
- Stern, Daniel. N. *The Interpersonal World of the Infant: A View from Psychoanalysis and Developmental Psychology.* London: Routledge, 1985.
- Umiltà Maria Alessandra et al. "Abstract Art and Cortical Motor Activation: an EEG study." *Front Hum Neurosci.* 16, no. 6 (2012): 311.
- Zeki, Semir. "Inner Vision: An Exploration of Art and the Brain.", Oxford: *Oxford University Press*, 1999.



## Abstract - Affective - Multimodal<sup>1</sup>

Interaction between Medium and Perception of Moving Images  
from the Viewpoint of Cassirer's, Langer's and Krois'  
Embodiment Theories

Martina Sauer

### Abstract

Everyday media consumption leaves no doubt that the perception of moving images from various media is characterized by experience and understanding. Corresponding research in this field has shown that the stimulus patterns flooding in on us are not only processed mentally, but also bodily. Building on this, the following study argues that incoming stimuli are processed not only visually, but multimodally, with all senses, and moreover affectively. The classical binding of a sensory organ to a medium, on whose delimitation the common understanding of multimodality is based, is thus abolished. Can arguments for this assumption be found? Building on the research of cultural anthropologist Ernst Cassirer and his successors, the two American philosophers Susanne K. Langer and John M. Krois, and supported by research from the life sciences in which, in parallel, the arts also play an important role in understanding image formation, as in the work of Heinz Werner and, following on from this, in the more recent research of the child psychologist Daniel N. Stern in collaboration with mirror neuron research by the group of neuroscientists around Giacomo Rizzolatti in Parma, justifications for this will be provided. What the multimodal processing of film images is concretely based on will finally be made clear by means of an exemplary analysis of a video film by the Swiss artist Pipilotti Rist. It aims to prove, that the prerequisites for the thesis can only lie in the fact, that both the modes of perception (visual, tactile, auditory, olfactory, gustatory) as well as the medially conditioned modes of image formation are based on non-discursive, formal-abstract structures that are also processed affectively. At the same time, the analysis thus shows how the selection and composition of the vital experienced forms can provide information about the socio-culturally shaped self-image of the producer and the viewer.

## Derivation

The virulent discussion about the question of the connection between perception and image formation at the beginning of the 20th century can be observed in various research perspectives that dealt with it without mentioning the concept of medium or multimodality. Rather, the question of how the world is perceived was examined by means of (mostly painted) pictures. In this regard, the initial focus was on the mode of image formation, which was considered to be informative for this purpose. The fact that it not only addresses the visual, but above all the tactile perceptual ability was a central starting point. The discussion was further stimulated by the fact that, in addition to the obvious multimodality, the affective capacity of the recipient was also addressed. It quickly became clear that in addition to the mental processing of the composition, which aims to give it meaning, there is also a physical processing. It was precisely the aesthetically, bodily sensory arousal potential of the works that stimulated reflection. How can we understand the experience, the felt liveliness that is able to flow through the recipient of a work? Do the works have to be configured in a certain way in order to appear meaningful and, moreover, to appeal to different senses as well as to arouse sensations? But if this is so, what is the relationship between the experience of images and the perception of the world? Can a difference be shown between the two? Are the mechanisms of perception not universal? Alongside the sciences of art and philosophy, the life sciences have thus made an important contribution to the clarification of these questions from the very beginning, be it psychological, biological and zoological or neuroscientific research results. Already these early researches opened up that both, the perception of an image and the perception of the world, have to operate according to the same rules. It was implicitly assumed that there must be an analogy between the perception of worldly and creative aspects. What does it consist of? What connects worldly and medially mediated phenomena in such a way that they can be perceived, felt and understood with all senses?

Remarkably, it is precisely the early research on these questions, which remain open to this day, that I consider to be able to contribute to their clarification. Their focus on organizational forms can be seen crucial in this respect. They already emphasize that the principles according to which they are organized are purely formal and to that extent abstract. This basic idea will be adhered to in what follows. For from it can be derived according to the thesis put forward here, the common ground that can be regarded as the precondition of the analogy between worldly and medially conditioned perception.

Against this backdrop, it is assumed that the non-discursive mode of appearance of formal-abstract elements have no intrinsic meanings, as already Hans Jürgen Wulff states (Lexikon der Filmbegriffe: diskursiv/präsentativ, latest update 2022). The proof that basically every medium is based on such non-discursive and thus abstract-formal elements has been elaborated by the philosopher Susanne K. Langer in four successive writings ([1953] 1967, 103, 369, 372). In this she coincides with research in developmental psychology, presented since the beginning of the century by the influential researcher Heinz Werner in 1926 and 1940, also confirmed by the current research of the American Daniel N. Stern since the 1980s, according to which all senses and, beyond that, the affective capacity of the recipient can potentially be addressed through them. In this sense, formal-abstract structures are not only multimedial, but also multimodal or basically amodal in nature (Werner [1926] 1959, 66-7, [1940] 1957, 96-7; Stern 1985, 47-68, 2010, [1985] 1992, 74-103, 2011). Against this background, it is natural to assume, as first advanced by the cultural anthropologist Ernst Cassirer, among others, in his exchange with Werner, and as taken up by the two pragmatist-influenced researchers Susanne K. Langer and John M. Krois, that the perception of world is also guided by the same principles (Sauer 2014b).

## Research Background

In retrospect, it seems like a unique historical event how the University of Hamburg, newly founded in 1919, created a space in which researchers from different disciplines pursued the most pressing questions of the time together in close exchange, if only for a short time, until most of them had to emigrate with Hitler's seizure of power in 1933. One central question that researchers have asked themselves can certainly be seen as the one that arose in the wake of Darwinian research: what distinguishes humans from animals? (Hartung [2001] 2004, 11-82). In addition to the human being's power to form images and to act, it is above all in-depth questions of perception theory that have become the focus of common interest with regard to the formation of consciousness. Through them, the interests of the philosopher Ernst Cassirer met with those of the art and cultural scientist Aby M. Warburg and of the art historian Erwin Panofsky, but also with the research of the biologist Jacob von Uexküll, the psychologist Heinz Werner and the Bauhaus master Gertrud Grunow, to name just a few.<sup>2</sup>



Remarkably, their questions are primarily related to those from art history or formal aesthetics, in which the relationship between modes of perception and modes of image formation has been focus of discussion (Wiesing [1997] 2008, 25–205). Until the 1980s, their research was based on the concept that the particular view of the producer determined the method of image formation (Sauer 2016). Thus, an optical view of the world produces different images from a haptic one (Riegl 1901), a painterly one from a linear one, as can be seen in the example of Baroque and Renaissance artifacts (Wölfflin [1915] 1923) and a dynamic (painterly) one from a representational (linear) one (Imdahl 1974, 325, 1987, 14–34, esp. 33). Only Gottfried Boehm, who founded the research center *Eikones* in Basel in 2006, departed from this specification, although he too explicitly followed Imdahl's terminology and distinguished between processes of perception that take place simultaneously (visual, dynamic seeing) and successively (object seeing), to which, however, he did not assign any specific modes of image formation, be they painterly or linear (Boehm 1980, 120–22). This in turn has far-reaching consequences, since with the separation of perception and image formation no functional connection can be established on which a semiological and thus historically-culturally relevant theory could be built. This is also reflected in the research that follows Boehm's theory of images (Alloa 2014, cf. review of Sauer 2015a) and in the far-reaching critique that his approach, but also that of Horst Bredekamp, has triggered, as will be shown below (Wiesing 2013, cf. review of Sauer 2014a).

In contrast to the approach of formal aesthetics, which was well known in the Hamburg circle (Panofsky [1932–1964] 1984, 187), the Hamburg researchers took a different approach. Basically, it was Ernst Cassirer who made the new considerations public with his main work, the three volumes of the *Philosophy of Symbolic Forms* published in 1923, 1924–25 and 1929. They are expressed in a theory of perception he developed, which is based on the premise that humans fundamentally do not perceive objectively, but are subjectively shaped by the affective reading of forms of motion and spatial forms; it forms the core of his theory of culture (Sauer 2008). Cassirer called this original perceptual activity expression-perception (Cassirer [1929] 1964, 94, [1929] 1979, 80). It concerns perception in general as well as image perception in particular, as he partly recorded in his late writing *An Essay on Man*, which he set down during the time of his American exile in 1942 ([1944] 1953, 190, [1944] 2007, 229). In distinction to formal-aesthetic assumptions, it can be stated, without this being explicitly addressed by Cassirer, that it is not intentional decisions to process the world be

it optically-dynamically or haptically-objectively, but that the differences in the stylistic conception of motifs (painterly and linear) observable over epochs are based on the premise that humans always and insofar directly experience the world as dynamically organized. This gives rise to the thesis—not to be developed further in the context of this study—that the variation in the stylistic elaboration then depends on the respective unconscious, culturally shaped mood.

For the question pursued here, which is interested in the interaction between perception and medium, it is rather essential to point out that Cassirer—just like formal aesthetics—assumes a functional connection between modes of perception and modes of images forming. According to both approaches, it is based on formal-abstract principles. But the one, what constitutes the perception in the world as dynamically-moved, are, according to Cassirer, not the objects as such, but precisely the forms of motion and spatial forms and thus also non-discursive, formal-abstract aspects. In the perception of the image, it is again abstract-formal elements and explicitly not the recognizable motifs that are grasped as “living forms” ([1944] 1953, 194, [1944] 2007, 233–34). Anthropologically conditioned, man is, as Cassirer put it following research from the life sciences<sup>3</sup> in particular, determined by a “libidinal underlayer”, so that man always interprets everything as a dynamic event (Cassirer [1929] 1964, 78, 94, [1929] 1979, 66–7, 80). Anything that is perceived through the original form of perception, expressive perception, can therefore always be seen as symbolically significant (Cassirer [1929] 1964, 222–37, esp. 234–35, [1929] 1979, 191ff.). Aby M. Warburg, in particular, followed Cassirer in this view, creating, for example, a *Mnemosyne Atlas*, which collected the migrations of sensations, the so-called *pathos formula*, captured by expressive perception, as they are capable of expressing themselves, according to the initial thesis, in images of all cultures, and to this end compiled a comprehensive library (Böhme 1997). On the other hand, the methodological distinctions of the art historian Erwin Panofsky between phenomenon sense, meaning sense and document sense (sense of essence) or pre-iconographic, iconographic and iconological method ([1932–1964] 1984, [1939–1955] 1984) do not allow a direct connection to Cassirer’s theory of perception, even if he apparently oriented himself with it on the threefold division of the modes of consciousness that Cassirer introduced. According to them, the mythical, descriptive-aesthetic, and theoretical modes of consciousness allow man to distance himself from the original living mode of perception of the world (expression perception) through processes of detachment, without, however, ever losing the connection to it (Cassirer [1929]

1964, 103, [1929] 1979, 87). Thus Panofsky, too, initially emphasized the primarily perceptible layer of sense, the “phenomenal sense”, through which man grasps both the expression of what he sees and the factual sense. In contrast to Cassirer, however, he immediately inferred discrete emotions such as sad or happy and thus concrete impressions that we can get from a face, for example (Sauer 2020).

Cassirer, on the other hand, understands what is grasped by expressive perception as something much more indeterminate, namely only impulses and directions (forms of motion and spatial forms) that can be perceived as vigorous or weak (Cassirer [1929] 1964, 94, [1929] 1979, 80). Thus, Panofsky already loses touch with Cassirer’s distinctions with the introduction of the so-called pre-iconographic method. With the iconographic method, Panofsky then provided a set of instruments by means with which the stylistic differences and their corresponding meanings in the representation of a motif were comparatively recorded. In this way it was possible to create a catalogue of typologies, which is still used today, and in which, for example, the characteristic differences of the depictions Mary are recorded (Lexikon der christlichen Ikonographie, 1968–76). In this methodological approach, analogies to the descriptive-aesthetic mode of consciousness become apparent. Points of reference to theoretical consciousness are furthermore evident in Panofsky’s iconological approach, through which the respective historical significance of the works can be developed by exploring their context. From a methodological point of view, Panofsky’s criteria of distinction have a pragmatic function in that, comparable to Cassirer’s approach, they can reveal the cultural-historical foundations of man, which he himself creates by means of symbolic forms (Cassirer [1929] 1964, 222–37, [1929] 1979, 191ff.; Panofsky [1939–55] 1984, 212). But just as formal aesthetics eventually loses its reference to the historical-cultural lifeworld, Panofsky’s iconological method, which is still valid for (cultural) visual studies and art history today, also tends to neglect the specificity of the image formation level. But just as formal aesthetics ultimately loses touch with the historical-cultural lifeworld (Prange 2004, 174–215, esp. 214–15), Panofsky’s iconological method, which is still valid for visual studies and art history today, tends to neglect the specificity of the formal level (Imdahl 1979, 14–5; Boehm [1978] 1985, 452–53). This, in turn, fundamentally contradicts the approach of Cassirer, who, however, only in his late writing, i.e. after the appearance of Panofsky’s first essays on the subject, explicitly stated that the perception of the recipient is ignited precisely by the formal-abstract elements, the “living forms” of the artworks, and in this way reality conveys reality via the works in a heightened

manner (Cassirer [1944] 1953, 194, [1944] 2007, 233). Indirectly, however, this approach has already been presented in the third, summary volume on the philosophy of symbolic forms:

Within this horizon, actually, the expressive perception is not only psychologically earlier than the perception of things .... It has its specific form, its own essentiality, which cannot be described, much replaced, by categories valid for other regions of being and meaning. ... The linguistic designation of movement, for example, almost always discloses this factor: instead of describing form of the movement as such, as the form of an objective spatial temporal process, language names and fixates the condition of which movement in question is an expression. "Quick," "slow," and if even "abrupt"—writes Klages, ...—may be understood in terms of pure mathematics; but "hurried," "restrained," "circumspect," "exaggerated" are just names for conditions of life as for kinds of movement, and describe the latter by indicating their characters. Anyone who to characterize forms of motion and spatial forms, finds himself pectedly entangled in a characterization of psychic attributes, forms and movements have been experienced as psychic phenomena before they are judged by the understanding from the standpoint objectivity, and because language can express objective concepts through the mediation of the experience of impressions. (Cassirer [1929] 1979, 80, [1929] 1964, 94)

Accordingly, Cassirer characterizes this original form of perceiving as one that is characterized by experiencing and suffering. What is apprehended thereby receives an expression (Cassirer [1929] 1964, 88, [1929] 1979, 75). What is grasped in this way thus acquires a direction of meaning.

Against the backdrop of the ambivalent reception of Cassirer's approach in the art sciences, it is not these who take up the theory of perception in the immediate aftermath. This can also be blamed on Cassirer himself, since he no longer explicitly addresses the approach that is fundamental to his philosophy in his late writings. Thus, due to Cassirer's emigration via several stations to the US, it is the two American researchers who stand in the tradition of pragmatism, who follow up to him. Among them, starting in the 1940s, are the Whitehead's student Susanne K. Langer and, much later, the co-founder of *Bildakt* at the

Humboldt University in Berlin John Michael Krois, also from America, who refers fundamentally on Peirce (Sauer 2014b). Even before Cassirer's late work appeared in America in 1944, Langer building on the latter's theory of perception and that of Whitehead, developed her own approach to art theory, which she published in 1942 and systematically expanded in further writings in 1953, 1967, and 1972 (54–60). In doing so, she concretely tied in with the affective-emotional experience of the human being, which both researchers had made strong, and which accordingly does not already express itself in discrete emotions, be it sadness, joy, anger, etc., but only in directional impulses, rhythms, and forms Cassirer ([1929] 1964, 88, 94, [1929] 1979, 75, 80; Whitehead 1927, 26–59, esp. 45, 2000, 101, 106; Sauer 2014b, 12–7, 2022). As Cassirer then elaborates in his late work, this kind of experience is retrieved precisely in the encounter with art. Thus, the content of art is “the verbally ineffable, yet not inexpressible law of vital experience, the pattern of affective and sentient being.” (Langer 1942, 209, [1942] 1965, 252). Understanding them demands familiarity with the “implicit” (rather than discursive or presentational) meaning of the works, which requires its own “non-discursive” forms of understanding (Langer 1942, 212–16, [1942] 1965, 256–60). The non-discursive forms of understanding correspond, as already indirectly discernible in Cassirer, to formal-abstract modes of image formation. According to Langer, the latter are based in music in the “tonal dynamic form” and in painting, sculpture, and poetry in the “play of lines, masses, colors, and substances.” Whereby the content of artistic expression itself, as Langer still suggested as a presumption in this early writing and made it a topic in *Feeling and Form* 1953, was the same in all arts as in music (Langer [1953] 1967, 103, 369, 372). Accordingly, Langer defined art as “the creation of forms symbolic of human feeling” (40). The concrete symbol-forming power lies in the fact that a “virtual” image of organic life emerges through the tensions and resolutions of the artistic means (206–07, 47–59, 372). It is based on the close relationship between organic (bodily, the present author) or mental processes (“vital forms”) and artistic (“artistic forms”). There must be an analogy between them. This is the basis of Langer's (image-)act theory as presented in the double volume *Mind. A Philosophy of Human Feeling*, the first volume of which appeared in 1967 and the second in 1972 (Langer [1967] 1985, 199–253). Only in interaction, according to Langer, do they become symbolically (emotionally) significant. In the logical or dialectical pattern (“tension and resolution”) of the possible relations (“potential acts”), the meaning of appearance is formed as a “living form” or “illusion of bodily existence” (206).



However, to exclude this mode of action with reference to entertainment and ritual, as Langer assumes, because they pursue purposes, can hardly tenable. The assumption contradicts her own approach, according to which the processes of superordination and subordination of acts (“tensions and resolutions”) not only constitute the behavior and thus the development of humans, but affect all areas of life. Thus, they can already be observed at the molecular level, which is controlled by physical and chemical processes. From a functional point of view, the foundation of developmental processes in dialectical acts thus enables the transfer of action-relevant information from one level to another. Understanding them consciously and translating them accordingly into media can therefore be regarded as the basis of human communication and development. Meanwhile, as mentioned in the introduction, recent studies in developmental psychology and neurosciences support this assumption (Stern 1985; 2010, [1985] 1992, [2010] 2011; Freedberg and Gallese 2007; Rizzolatti et al. 2013, Di Cesare et al. 2020).

Langer’s (image-)act understanding coincides in many respects with that of Cassirer expert John M. Krois (Sauer 2014b, 54–60). He, too, assumes that expressive understanding fundamentally constitutes human access to the world; it is physically bound (Krois 1987, 57, 85f.) and can accordingly be understood as a function of all higher symbolic forms (with symbolic conciseness). It is “the logical structure of experience” (47). Only late, however, in the last year of his life in 2010, does it become concrete for the researcher, in an engagement with enactivism (Freedberg and Gallese 2007; Krois [2011] 2010b, 237f.), that the understanding of an expressive meaning cannot only be related to the formation of will and thus to the desires and purposes pursued by it in a process of weighing (“evaluation process”, Krois 1987, 155, 167, 102–05), but is related to the perceptual processes themselves. Thus, the theory of embodiment addressed by Krois in several recent essays gains contour (Bredenkamp and Lauschke 2011; Sauer 2013). It is based on the assumption that both the image and the body (or the perception of humans, but also of animals and robots) are built on comparable principles or schemata. Accordingly, it can be summarized that there is an analogy between image schemata and body schemata: “In all of them, body schemata are built up from the same image schemata. These image schemata are dynamic, non-optical forms [...]” Experiencing and feeling them consciously (as “qualities”, Krois [2011] 2010a, 231) through “expressive perception” (Krois 2011a, 270) distinguishes humans from animals.

Nevertheless, Krois asserts at various points—ultimately in contrast to his own statements—that although there are dynamic, affectively effective aspects in the image, which, as Cassirer and Langer also formulated, are based on abstract-formal principles, these are independent of the intentions of the producers and thus of the interpretation of the recipients (Krois, 2011a, 269; 2011b, 278; 2011c, 306).

The usurpatory character of pictorial objects—the fact that they possess affective meanings independently of the artists' intentions and the viewer's deliberate interpretations—results from the fact that like the viewer, they too embody dynamic affective image schemas. (Krois 2010b [2011], 251)

Against this backdrop, it can be stated with Krois, that the image is not a communication and consequently has no relevance for action. This contradictory ambivalence also characterizes the art historical research of Horst Bredekamp, who founded *Bildakt* with Krois in 2008 (Bredekamp 2010, 51–6). In doing so, he disappointed the hopes of historians in particular, who, inspired by his lecture at the German Historians' Conference in Constance in 2006 (2007, 289–309), hoped that the publication of *Bildakt* 2010 would provide operationalizable solutions for analyzing images in such a way that their agency would emerge (Jäger 2011; Sauer 2015b). Finally, it is the implicit presuppositions in Bredekamp's approach, which can also be found in Gottfried Boehm's work, that triggered fierce criticism because they would present images as independent actors and thus anthropomorphize them (Wiesing 2013, 78–107; Sauer 2014a).

### Pipilotti Rist: *I'm Not The Girl Who Misses Much*, Video, 5'02, 1986

Contrary to this criticism, as it was formulated not entirely unjustifiably by Wiesing, both in Boehm's and Bredekamp's approach, against the background of the tradition of formal aesthetics within the art studies shown here and the cultural anthropological research as founded by Cassirer, an approach can be presented that is able to overcome the discrepancies. For if we assume that not only the perception of images, but already that of the world is based on non-discursive, formal-abstract aspects which can be taken in multimodally with all senses and, moreover, can be interpreted affectively-emotionally by us, then a conclusive concept emerges as to what extent unconscious, bodily processes can be seen as a prerequisite for how information and sensations translated by us into media can be understood. In particular, developmental psychologist

Daniel N. Stern has elaborated in research how fundamental this mode of perception is to social behavior and, moreover, to the perception of art (1985, 157–61, 2010, [1985] 1992, 228–30, [2010] 2011). However, unlike the interpretive processes in everyday perception, whose mechanisms of action go unnoticed, they become visible to us in the face of art. This reflects an assumption not only expressed by Stern (1985, 160–61, [1985] 1992, 225–230) and earlier by Werner ([1926] 1959, 61–73, [1940] 1957, 59–72) but was also articulated in this way by Cassirer and Langer (Cassirer [1929] 1964, 88, [1929] 1979, 75, [1944] 1953, 189, [1944] 2007, 228; Langer 1942, 199–216, esp. 211, [1942] 1965, 241–260, esp. 254). Moreover, it seems self-evident that it is not in the interest of advertising and propaganda to reveal those processes through which they can unconsciously influence the sensations and thus the decisions of recipients (Sauer 2012a: 11–23, 194, 266–67, 283). It is noteworthy that in my view this contrasting interest is also reflected in recent film production in comparison to the computer game industry. While films such as *Inception* (USA 2010) or *Gamer* (USA 2009) are concerned with openly exploring the fictional possibilities of immersive processes, computer games aim to blur the boundaries between fiction and reality.

The following exemplary analysis of a video by the well-known Swiss video artist Pipilotti Rist is intended to show the extent to which the arts are not only concerned with revealing processes of perception and formation and their effects, but also with provoking reactions (Sauer 2012b). This is a video that the artist realized in 1986 during her formative years at the Basel Kunstgewerbeschule, now the Academy of Art and Design, and through which she became known at a stroke: *I'm Not The Girl Who Misses Much* (Fig. 1).

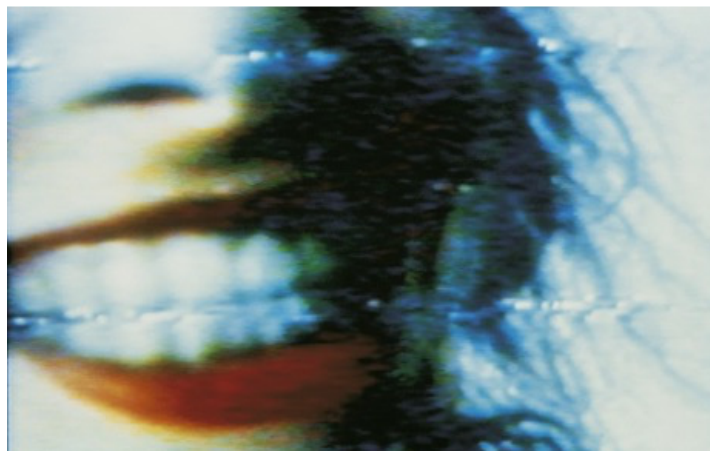
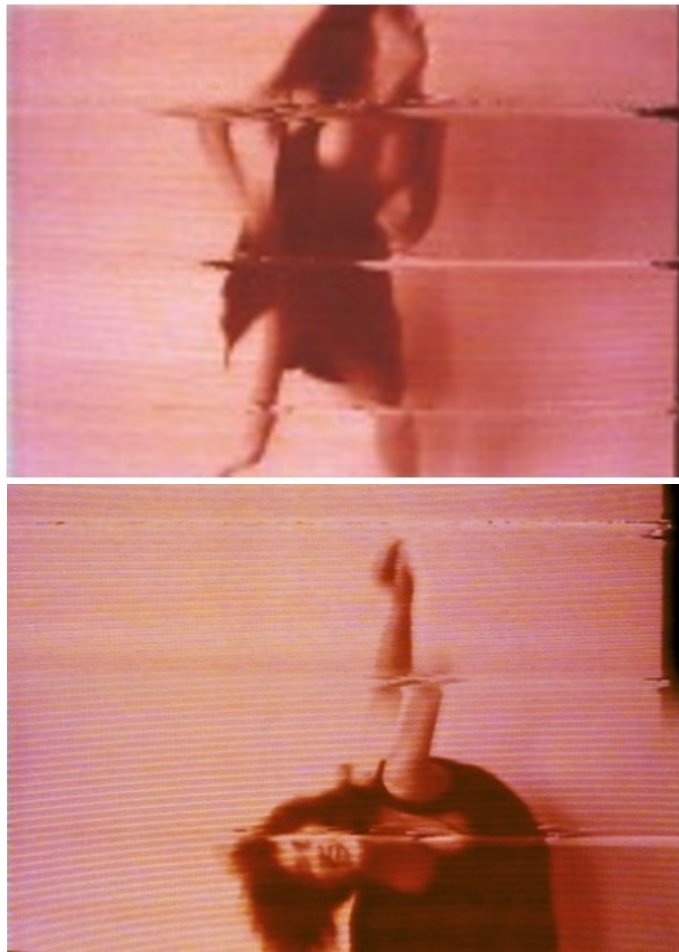

Figure 1. Pipilotti Rist, *I'm Not The Girl Who Misses Much*, 1986.

Video (video still), © Pipilotti Rist, Courtesy the artist, Hauser & Wirth and Luhring Augustine

With the playful use of partly bizarre, partly funny effects and parallel video-technical procedures, the video artist not only caricatures a Beatles song, which also gave the video its title, but at the same time reveals the mechanisms of effect of the formation possibilities with moving images and thus also the modes of perception of the recipient. The following analysis pursues the opposite approach. It attempts to work out, via description, the specific formal-abstract aspects which, it is assumed, are affectively evaluated by us in parallel with our perception of the world and thus independently of culture. What influence this mode of perception has on the interpretation of the simultaneously recognizable elements and on the possibilities of active engagement with them must be shown, because this influence, according to the thesis, can be considered fundamental for the possibility of interaction and communication via media.

What the artist shows with the video is quickly told. In the tape, which lasts only five minutes, a young woman in a small black dress with open bosom dances and sings only blurred visible. Initially pixelated large, with a red filter and audible sequence soundtrack, the title of the video appears, enlarging and shrinking again. A sequence of events that we immediately follow and whose ambivalence we just as immediately transfer to the content of the text. It is this experience that shapes the interpretation of the meaning of the words, this can be emphasized here. The hectic movements and the face of a dancer behind the writing can be seen in fast forward and changing zoom settings, at first only very blurred. Then the shots switch to normal color. The lettering disappears and the dancer herself appears and becomes the subject. Still pixelated-blurred, color reduced to black and white with a slight red-green-blue shadow, her movements seem distorted puppy-choppy by the time-lapse. A short song lyric "I'm not the girl who is missing much" is repeated by her over and over again. The rhythm of the repetition and the time-lapse connects with the choppy movements. The performance style adds to this effect: the voice is breathless, high-pitched and squeaky. This performance experiences a new interruption as the medium itself becomes the subject through the flickering of the recording and the stripes in the scrolling. It becomes obvious, that the scene was shot with a still camera, and the dancer moves partly out of the frame or directly toward the camera. The performance is distorted or transformed by the use of a red filter (Figs. 2–3).



Figures 2–3. Pipilotti Rist, *I'm Not The Girl Who Misses Much*, 1986.

Video (video still), © Pipilotti Rist, Courtesy the artist, Hauser & Wirth and Luhring Augustine

The image space is thus once again considerably flattened. In slow motion, as if from off-screen, the song lyrics are heard again, the dancer now lies below the field of vision, apparently on the floor, and slowly straightens up again. She takes the lead again and sings and dances even faster than before. Slow motion and fast motion, as well as the color change and the accompanying changing spatial impression, contrast violently with each other and intensify the effect. The performance, already bizarre at the beginning, takes on comic, slapstick traits in its urgency. Almost incantatory, the dancer sings the text over and over to herself and to us during her performance. All that happens through the staging of the formal elements and becomes affectively experienceable for us is here transferred to the scene and the text. Their context and meaning are suddenly called into question by the intensification of the effects. Then the film breaks down. Once again, the shot flickers and tear marks distort the scene (Figs. 4–5).



Figures 4–5. Pipilotti Rist, *I'm Not The Girl Who Misses Much*, 1986  
Video (video still), © Pipilotti Rist, Courtesy the artist, Hauser & Wirth and Luhring Augustine

Questions about the meaning of what has been experienced and seen are not left out. But only with a deeper search for the references and background of the text it becomes clear that the video is directly related to a Beatles song written by John Lennon and Paul McCartney and published in the same year as the video, 1968. It talks about a girl and/or drugs, who lacks nothing sexually / intoxicatingly, but instead of “she’s” Rist says “I’m not the girl who misses much” from the song *Happiness Is a Warm Gun*. Ultimately, however, it is not so much the song and the girl as the staging techniques that irritate us. Both the girl and we with her are electrified by it: We experience the frenzy of the movements, dive into the red space, sink to the floor with her, become breathless, feel the rhythm and the turmoil. At the same time, we are able to reconcile these experiences with our own prior experiences and knowledge, so that we also simultaneously grasp the distortions or artificiality of the scene and the recording.



At a third level of experience, we relate all the information conveyed by the distortions to the dancer, her movements, and the song line she performed. In this way, we see how the artist's creative actions or formal choices become essential to the production of meaning.

Understanding here proves to begin with an immediate experience and a "suffering"<sup>4</sup> which "are at first a mere passivity, a being acted-upon rather than action" (Cassirer [1929] 1979, 75), and takes on concrete forms in comparison with one's own prior experiences and prior knowledge. Accordingly, in retrospect, conclusions can be drawn about what the artist wants to tell us with the video: instead of having everything and thus missing nothing, as the girl pretends with the constant repetition of the song's lyrics, she never seems to achieve this goal. Her attempts take on almost desperate-grotesque features. In the process, her performance never for a moment becomes concrete or clearer. On the contrary, what she wants to show herself and us threatens to slip away. She sings and fakes something for herself and for us. What she then shows us is the dancing and singing itself with bosom exposed and high-pitched squeaky voice. It does not gain any depth. In this respect, it is only a cliché or the image of a role that she wants to convincingly play for herself and for us. But just as the role-image does not work for the girl, the recipient also fails: instead of watching a seductive young girl herself/actualizing herself, this takes on clownish traits. It degenerates into a farce. This production, like others by the artist, completely eludes a possibly lustful, voyeuristic gaze or a possibly imitable role model function.

## Conclusion

Perception in general, and thus also the perception of moving images produced with technical aids, is, as it was to be clarified against the background of cultural anthropological research and the exemplary analysis of the Rist video, not oriented solely factually to the recording of things and course of action, but allows itself to be affected by their formal-abstract modes of appearance. That is, it is oriented not only to what, but at the same time to the way something shows itself to us. In relation to moving images, these are the staging techniques and thus the respective settings with which the 18 or so images and their sequence are realized. Basically, it is they and thus the formally abstract modes of appearance that are consequently not only interpreted in terms of their possible nameable meanings, but at the same time captured in a bodily, affectively vital way. Decisive for the latter is, as a closer look reveals, how fast or slow, here how hectic or artificially slowed down a perceived movement turns out to be. Which direction it takes, whether it comes towards us or moves away. Equally significant are the sounds that accompany the movement, whether they appear suddenly and loudly like the rustling of the film reel or develop into a breathless, hectic, almost no longer intelligible chant, or whether they come from a distance, slowed down in tempo like the voice from off-screen. In addition, the shapes of the figures prove important, whether they elude us or constantly change their size and extension, as in the beginning of the song line and then in the case of the dancer through the blurred contours and abrupt movements. Finally, the constant change of space, alternating between real and color space and eventually culminating in the view of the tearing film reel, also contributes to the uncertainty. For the experience of the video, in this respect, it is the changes of form, the changes of direction, and the vehemence or degrees of intensity of the movements, as well as the changing speeds or time patterns of the movements and sounds, that determine our most immediate affective experience of what is happening.

It is thus both the movements of the dancer herself and the movements initiated by the artistic means, in this case the video staging techniques of the 1980s, that can be held responsible. This means that it is ultimately irrelevant for the experience itself whether it is afflicted by mundane or media-staged stimuli and by which techniques and materials it is to be accounted for. The stimulus value for the experience depends on the forms, degrees of intensity, and temporal patterns that trigger it, and on the immediacy with which it is experienced.

This is a connection that child psychologist Daniel N. Stern first worked out so clearly (Stern 1985, 47–68, esp. 52, [1985] 1992, 74–103, esp. 80; Sauer 2012a: 79–92, esp. 83–6)<sup>5</sup>. The remarkable thing about experience is that there is no difference between the real and the fictional world. Ultimately, it is one's prior experiences and prior knowledge that can be seen as central to the degree of distancing and the corresponding conscious evaluation of what is experienced, depending on the degree to which they are admitted. That is, the less distancing processes are induced during enactment, for example by pauses, the higher the degree of immersion and the stronger the sense of one's own body can fade, as recent empirical studies with reference to the experience of computer game worlds have shown (Weger and Lounghnan 2014).

## Authors Biography

**Martina Sauer** runs the Institute of Image and Cultural Philosophy in Bühl (Baden), Germany: [www.bildphilosophie.de](http://www.bildphilosophie.de). She is a senior editor of *Art Style, Art & Culture International Magazine* and a scientific advisor of the Society of Interdisciplinary Image Science and the German Society of Semiotics. She was a scientific associate in philosophy of art and culture, aesthetics and design in Basel, Zürich, Bremen, Witten as well as a scientific associate at Bauhaus-University Weimar. Currently, she holds seminars on the fundamentals of perception at Fresenius University of Applied Sciences, AMD Düsseldorf and Hamburg. Recently, she also initiated and realized a research project there together with Petra Leutner on "Affective Perception and Design" with the neuroscientists Giuseppe di Cesare and Giada Lombardi from Parma, Genua. For further publications see on: [arthistoricm.net](http://arthistoricm.net), [researchgate.net](http://researchgate.net), [academia.edu](http://academia.edu), [philpeople.org](http://philpeople.org): Contact: [msauer@bildphilosophie.de](mailto:msauer@bildphilosophie.de). ORCID: 0000-0002-4787-3189.

## Notes

1. The study is the result of a close collaboration with the Research Group for Moving Image Studies in Northern Germany, Kiel, which in turn is closely associated with this present edition, following a joint conference. Recent research literature and some text passages have been added. In addition, writings by Ernst Cassirer, Susanne K. Langer, Alfred N. Whitehead, Heinz Werner, and Daniel N. Stern, originally cited from German editions, have been supplemented with text passages from English ones. In this issue this article appears in a revised and updated 2nd edition. Originally, it was published in German in the 2nd volume of the *Yearbook of Moving Image Studies* on the special topic of *Image Bodies (Bildkörper). On the Relationship between Image Technologies and Embodiment*, edited by Lars Christian Grabbe, Patrick Rupert Kruse, and Norbert M. Schmitz (Marburg: Büchner Verlag, 2016), 46–71.

2. In order to provide at least a glimpse of their research within the limited scope of this study, reference is made to some of their writings, most of which have been and continue to be highly influential in their field of study: on Warburg cf. Böhme (1997), on Panofsky ([1932–1964] 1984, [1939–1955] 1984) on Uexküll cf. Krois ([2007] 2011), on Werner ([1926] 1959, [1940] 1957, Sauer 2011), and on Grunow (1923).

3. In addition to the researchers already mentioned, the research approaches of Kurt Goldstein, a Frankfurt neurologist close to him (Krois [1999] 2011, 53–6, [2007] 2011, 188–90), the psychologist Ludwig Klages ([1913] 1950), the philosopher and psychologist Theodor Lipps (1899), and the philosopher, anthropologist, and sociologist Max Scheler ([1913] 1923) played a crucial role in his reflections on the theory of perception or the perception of expression. Cf. on the latter Cassirer's concrete references in the 3rd volume on the philosophy of symbolic forms ([1929] 1979, 58–91).

4. This reference to experiencing and "suffering", goes back to the original text in German, which is much more concrete: "Ausdruck ist zunächst nichts anderes als ein Erleiden; ist weit mehr ein Ergriffenwerden als ein Ergreifen" (Cassirer [1929] 1964, 88).

5. This is initially followed by Stern's joint research with Giacomo Rizzolatti's research group in Parma (Rizzolatti et al. 2013; Di Cesare et al. 2020), which is currently being concretized and referring to art and design by Giada Lombardi and Giuseppe di Cesare (2022). Cf. their contribution in this special issue and the first joint contribution in collaboration with me for the next issue on the topic of *Atmosphere and Mood* (forthcoming 2023).

## Bibliography

- Alloa, Emmanuel, ed. *Erscheinung und Ereignis. Zur Zeitlichkeit des Bildes*, München: Fink, 2013.
- Boehm, Gottfried. "Zu einer Hermeneutik des Bildes". In *Seminar: Die Hermeneutik und die Wissenschaften*, edited by Gottfried Boehm and Hans-Georg Gadamer. 1978. 2nd ed, 444–71. Frankfurt am Main, 1985.
- . "Bildsinn und Sinnesorgane." In *Neue Hefte für Philosophie*, special issue: *Anschauung als ästhetische Kategorie*, vol. 18/19 (1980): 118–32.
- Böhme, Hartmut. "Aby M. Warburg (1866-1929)." In *Klassiker der Religionswissenschaft. Von Friedrich Schleiermacher bis Mircea Eliade*, edited by Axel Michaels, 133–57. München: Beck, 1997. <https://www.hartmutboehme.de/media/Warburg.pdf>.
- Bredenkamp, Horst. "Schlussvortrag: Bild – Akt – Geschichte." In *GeschichtsBilder. 46. Deutscher Historikertag vom 19. bis 22. September in Konstanz. Berichtsband*, edited by Clemens Wischermann et al., 289–309. Konstanz: UVK, 2007.
- . *Theorie des Bildakts. Frankfurter Adornovorlesungen*, Frankfurt am Main: Suhrkamp, 2010.
- Bredenkamp, Horst and Marion Lauschke, eds. *John M. Krois. Bildkörper und Körperschema. Schriften zur Verkörperungstheorie ikonischer Formen*. Berlin: Akademie, 2011.
- Cassirer, Ernst. *Philosophie der symbolischen Formen*. Vol. 3. *Die Phänomenologie der Erkenntnis*. 1929. Darmstadt: Wissenschaftliche Verlagsgesellschaft, 1964.
- . *The Philosophy of Symbolic Forms*. Vol. 3. *The Phenomenology of Knowledge*. Translated by Ralph Mannheim. 1929. 10<sup>th</sup> edn. New Haven: Yale University Press, 1979.
- . *An Essay on Man. An Introduction to a Philosophy of Human Culture*. 1944. New York: Doubleday & Company, 1953.
- Di Cesare, Giuseppe, Marzio Gerbella, and Giacomo Rizzolatti. "The neural bases of vitality forms." *Natl Sci Rev* 7, 1 (2020): 202–13.
- Di Cesare, Giuseppe, and Giada Lombardi. "From Neuroscience to Art. The Role of "Vitality Forms" in the Investigation of Multimodality." Special edition, *Multimodality*, edited by Martina Sauer and Christiane Wagner. *Art Style, Art & Culture International Magazine*, v. 10, no. 10 (September 2022): 11-23.
- Freedberg, David, and Vittorio Gallese. "Motion, emotion and empathy in esthetic experience." In *Trends in Cognitive Sciences*, vol. 11, 5 (2007): 197–203. <https://pubmed.ncbi.nlm.nih.gov/17347026/>.
- Grunow, Gertrud. "Der Aufbau der lebendigen Form durch Farbe, Form, Ton." 1923. In *Ausstellungskatalog, Staatliches Bauhaus Weimar 1919 bis 1923*, edited by Lars Müller in collaboration with Bauhaus-Archiv. Berlin: Museum für Gestaltung, 2019.
- Hartung, Gerald. *Das Maß des Menschen. Aporien der philosophischen Anthropologie und ihre Auflösung in der Kulturphilosophie Ernst Cassirers*. Habil. Leipzig 2001. Weilerswist: Velbrück Wissenschaft 2004.
- Imdahl, Max. "Cézanne, Braque, Picasso. Zum Verhältnis zwischen Bildautonomie und Gegenstandssehen." In *Wallraff-Richards-Jahrbuch XXXVI, Westdeutsches Jahrbuch für Kunstgeschichte*. Köln. DuMont, 1974, 325–65.
- . *Giotto. Zur Frage der ikonischen Sinnstruktur*. München, 1979.
- . *Farbe. Kunsttheoretische Reflexionen in Frankreich*. München: Fink, 1987.
- Jäger, Jens. Review on: Hort Bredenkamp. *Theorie des Bildakts. Frankfurter Adornovorlesungen*, Frankfurt am Main: Suhrkamp, 2010. In *H-Soz-u-Kult*, 14.07.2011. Access date: July 13, 2022. <https://www.hsozkult.de/publicationreview/id/reb-15877?title=h-bredenkamp-theorie-des-bildakts&recno=4&q=2011-3-037&sort=newestPublished&fq=&total=6>.

- Klages, Ludwig. *Ausdrucksbewegung und Gestaltungskraft*. 1913. Leipzig: Wilhelm Engelmann. Accessed July 13, 2022. <https://archive.org/details/ausdrucksbewegu00klag>
- Krois, John M. *Cassirer. Symbolic Forms and History*. New Haven and London: Yale University Press, 1987.
- . "Cassirer's "Prototyp and Model" of Symbolism. Its Sources and Significance." 1999. In *John M. Krois. Bildkörper und Körperschema. Schriften zur Verkörperungstheorie ikonischer Formen*, edited by Horst Bredekamp and Marion Lauschke, 44–66. Berlin: Akademie, 2011.
- . "Philosophical Anthropology and the Embodied Cognition Paradigm." 2007. In *John M. Krois. Bildkörper und Körperschema. Schriften zur Verkörperungstheorie ikonischer Formen*, edited by Horst Bredekamp and Marion Lauschke. Berlin: Akademie, 2011, 176–93.
- . "Tastbilder. Zur Verkörperungstheorie ikonischer Formen." 2010a. In *John M. Krois. Bildkörper und Körperschema. Schriften zur Verkörperungstheorie ikonischer Formen*, edited by Horst Bredekamp and Marion Lauschke, 208–31. Berlin: Akademie, 2011.
- . "Experiencing Emotion in Depictions. Being Moved without Motion?" 2010b. In *John M. Krois. Bildkörper und Körperschema. Schriften zur Verkörperungstheorie ikonischer Formen*, edited by Horst Bredekamp and Marion Lauschke, 232–51. Berlin: Akademie, 2011.
- . "Bildkörper und Körperschema." 2011a. In *John M. Krois. Bildkörper und Körperschema. Schriften zur Verkörperungstheorie ikonischer Formen*, edited by Horst Bredekamp and Marion Lauschke, 252–71. Berlin: Akademie, 2011.
- . "Enactivism and Embodiment in Pictures Acts. The Chirality of Images." 2011b. In *John M. Krois. Bildkörper und Körperschema. Schriften zur Verkörperungstheorie ikonischer Formen*, edited by Horst Bredekamp and Marion Lauschke, 272–89. Berlin: Akademie, 2011.
- . "Was sind und was wollen die Bilder?" 2011c. In *John M. Krois. Bildkörper und Körperschema. Schriften zur Verkörperungstheorie ikonischer Formen*, edited by Horst Bredekamp and Marion Lauschke, 290–306. Berlin: Akademie, 2011.
- Langer, Susanne K. *Philosophie in a New Key. A Study in Symbolism of Reason, Rite, and Art*. 1942. 6th edn. New York: American Library, 1954.
- . *Philosophie auf neuem Wege. Das Symbol im Denken, im Ritus und in der Kunst*. 1942. Translated by Ada Löwith. 4th edn. Berlin: S. Fischer, 1965.
- . *Feeling and Form. A Theory of Art*. 1953. 4th edn. London: Routledge & Kegan, 1967.
- . *Mind. An Essay on Human Feeling*. Vol. 1. 1967. 4th edn. Baltimore, London: John Hopkins University Press, 1985.
- . *Mind. An Essay on Human Feeling*. Vol. 2. Baltimore, London: John Hopkins University Press, 1972.
- Lexikon der christlichen Ikonographie (1968–1976)*, edited by Engelbert Kirschbaum (vol. 1–4) and Wolfgang Braunfels (vol. 5–8). 8 Vol. Freiburg i. Breisgau: Herder 1994.
- Lipps, Theodor. *Die ethischen Grundfragen: Zehn Vorträge*. Hamburg and Leipzig: L. Voss. 1899. Accessed July 13, 2022. <https://archive.org/details/dieethischengru00lippgoog>
- Lombardi, Giada, Martina Sauer, and Giuseppe Di Cesare. "An Affective Perception: How "Vitality Forms" Influence Our Mood." Special edition, *Atmosphere and Mood*, edited by Martina Sauer and Zhuofei Wang. *Art Styl, Art & Culture International Magazine*, v. 11, no. 11, forthcoming 2023.
- Panofsky, Ernst. "Zum Problem der Beschreibung und Inhaltsdeutung von Werken der bildenden Kunst." 1932–1964. In *Bildende Kunst als Zeichensystem*. Vol. 1. *Ikonographie und Ikonologie: Theorien, Entwicklung, Probleme*, edited by Ekkehard Kaemmerling, 185–206. 3rd edn. Köln: DuMont, 1984.



- . "Ikonographie und Ikonologie." 1939–1955. In *Bildende Kunst als Zeichensystem*. Vol. 1. *Ikonographie und Ikonologie: Theorien, Entwicklung, Probleme*, edited by Ekkehard Kaemmerling, 207–25. 3rd edn. Köln: DuMont, 1984.
- Prange, Regine. *Die Geburt der Kunstgeschichte. Philosophische Ästhetik und empirische Wissenschaft*. Köln: Deubner, 2004.
- Riegl, Alois. *Die spätrömische Kunst-Industrie nach den Funden in Österreich-Ungarn im Zusammenhange mit der Gesamtentwicklung der Bildenden Künste bei den Mittelmeervölkern*, Wien: Österreichisches Archäologisches Institut, 1901. <https://doi.org/10.11588/diglit.1272#0001>.
- Rizzolatti, Giacomo et al. "The neural correlates of »vitality form« recognition: an fMRI study." In *Social Cognitive and Affective Neuroscience*, 05.06.2013: 1–34.
- Sauer, Martina. "Wahrnehmen von Sinn vor jeder sprachlichen oder gedanklichen Fassung? Frage an Ernst Cassirer." In *eJournal Kunstgeschichte*, 21.12.2008: <http://www.kunstgeschichte-ejournal.net/63/>, commented by Lambert Wiesing 30.12.2009. Accessed July 13, 2022. <https://www.kunstgeschichte-ejournal.net/296/>.
- . "Entwicklungspsychologie/Neurowissenschaft und Kunstgeschichte. Ein Beitrag zur Diskussion von Form als Grundlage von Wahrnehmungs- und Gestaltungsprinzipien." In *eJournal Kunstgeschichte*, 07.06.2011. Accessed July 13, 2022. <http://www.kunstgeschichte-ejournal.net/134/>.
- . *Faszination—Schrecken. Zur Handlungsrelevanz ästhetischer Erfahrung anhand Anselm Kiefers Deutschlandbilder*, Heidelberg: arthistoricum.net, 2012a: DOI: 10.11588/artdok.00001851.
- . "La beauté de l'ardeur pour la vie." In *Les lettres et les arts: cahiers suisses de critique littéraire et artistique*, no. 14, 11 (2012b): 58–61. DOI: 10.11588/artdok.00002158.
- . Review of John. M. Krois, *Bildkörper und Körperschema. Schriften zur Verkörperungstheorie ikonischer Forme*. Berlin: Akademie 2011. In *sehepunkte* 13, 4 (2013). Accessed July 13, 2022. <http://www.sehepunkte.de/2013/04/22945.html>.
- . Review of Lambert Wiesing. *Sehen Lassen. Die Praxis des Zeigens*, Berlin 2013. In *sehepunkte* 14, no. 3 (2014a). Accessed July 13, 2022. <http://www.sehepunkte.de/2014/03/25039.htm>.
- . "Ästhetik und Pragmatismus. Zur funktionalen Relevanz einer nicht-diskursiven Formauffassung bei Cassirer, Langer und Krois." In *IMAGE* 20, 7 (2014b). Accessed July 13, 2022. [https://www.gib.uni-tuebingen.de/own/journal/pdf/IMAGE\\_20\\_RD.pdf](https://www.gib.uni-tuebingen.de/own/journal/pdf/IMAGE_20_RD.pdf)
- . Review of *Erscheinung und Ereignis. Zur Zeitlichkeit des Bildes*, edited by Emmanuel Alloa München: Fink 2013. In *sehepunkte* 15, 1 (2015a). Accessed July 13, 2022. <http://www.sehepunkte.de/2015/01/25928.html>.
- . "Visualität und Geschichte. Bilder als historische Akteure im Anschluss an Verkörperungstheorien." In *Jenseits des Illustrativen. Visuelle Medien und Strategien politischer Kommunikation*, edited by Niels Grüne and Claus Oberhauser, 30–60. Göttingen: V&R, 2015b. DOI: 10.11588/artdok.00004293.
- . "Das Bild als semiotisches System. Kunst- und kulturwissenschaftliche Überlegungen zu Mechanismen, Prozessen und Praktiken der Bedeutungsgenerierung durch das bzw. im Medium Bild." In *Illustrierte Zeitschriften um 1900: Multimodalität und Metaisierung*, edited by Natalia Igl and Julia Menzel, 137–65. Bielefeld: transcript, 2016. DOI: 10.11588/artdok.00005308.
- . "Panofsky—Warburg—Cassirer. From Iconology to Image Science." In *Homo Pictor. Bildwissenschaft und Archäologien im Dialog*, edited by Jacobus Bracker, 159–171. Heidelberg: Propylaeum, 2020. DOI: 10.11588/propylaeum.709.

- . "Vitality Semiotics: A New Understanding of the *Conditio Humana*." In *The Future Wishpers: Susanne K. Langer's Philosophy*, edited by L. Gaikis. London: Bloomsbury: 2022 (forthcoming)
- Scheler, Max. *Die Sinngesetze des Emotionalen Lebens*. 1913. Vol. 1. 2nd edn. *Wesen und Formen der Sympathie*. Bonn: Verlag Friedrich Cohen 1923. Accessed July 13, 2022. <https://ru.de1lib.org/book/2489121/f92ea2>.
- Stern, Daniel N. *The Interpersonal World of the Infant. A View from Psychoanalysis and Developmental Psychology*. New York: Basic Books, 1985.
- . *Die Lebenserfahrung des Säuglings*. 1985. Translated by Elisabeth Vospohl. Stuttgart: Klett-Cotta, 1992
- . *Forms of Vitality. Exploring Dynamic Experience in Psychology, the Arts, Psychotherapy, and Development*. Oxford: University Press, 2010.
- . *Ausdrucksformen der Vitalität. Die Erforschung dynamischen Erlebens in Psychotherapie, Entwicklungspsychologie und den Künsten*. 2010. Translated by Elisabeth Vospohl. Frankfurt am Main: Brandes & Apsel, 2011.
- Werner, Heinz. *Einführung in die Entwicklungspsychologie*. 1926. 4th ed. München: Barth, 1959.
- . *Comparative Psychology of Mental Development*. 1940. 2th edn. New York: International University Press, 1957. Access date: July 13, 2022. <https://archive.org/details/in.ernet.dli.2015.138929/page/n11/mode/2up>.
- Weger, Ulrich W., and Stephen Lounghnan. "Virtually numbed: Immersive video gaming alters real-life experience." In *Psychonomic Bulletin & Review*, vol. 21, 4 (2014): 562-65.
- Whitehead, Alfred N. *Symbolism. Its Meaning and Effect*. New York: Little and Ives Company, 1927.
- . "Kulturelle Symbolisierung". 1927. In *Alfred North Whitehead, Kulturelle Symbolisierung*, edited by Rolf Lachmann. Translated by Rolf Lachmann, Frankfurt am Main: Suhrkamp, 2000.
- Wiesing, Lambert. *Die Sichtbarkeit des Bildes. Geschichte und Perspektiven der formalen Ästhetik*, 1997. Frankfurt am Main: Campus, 2008.
- . *Sehen lassen. Die Praxis des Zeigens*. Berlin: Suhrkamp, 2013.
- Wölfflin, Heinrich. *Kunstgeschichtliche Grundbegriffe. Das Problem der Stilentwicklung in der neueren Kunst*. 1915. 6th ed. München: Bruckmann, 1923.
- Wulff, Hans Jürgen. Lemmata: "diskursiv / präsentativ." Last update: 2022/03/22 23:22. In *Lexikon der Filmbegriffe*. Institut für Neuere Deutsche Literatur und Medien, Kiel. Accessed July 13, 2022. [https://filmlexikon.uni-kiel.de/doku.php/d:diskursivpräsentativ-4416?s\[\]=diskursiv&s\[\]=pr%C3%A4sentativ](https://filmlexikon.uni-kiel.de/doku.php/d:diskursivpräsentativ-4416?s[]=diskursiv&s[]=pr%C3%A4sentativ).

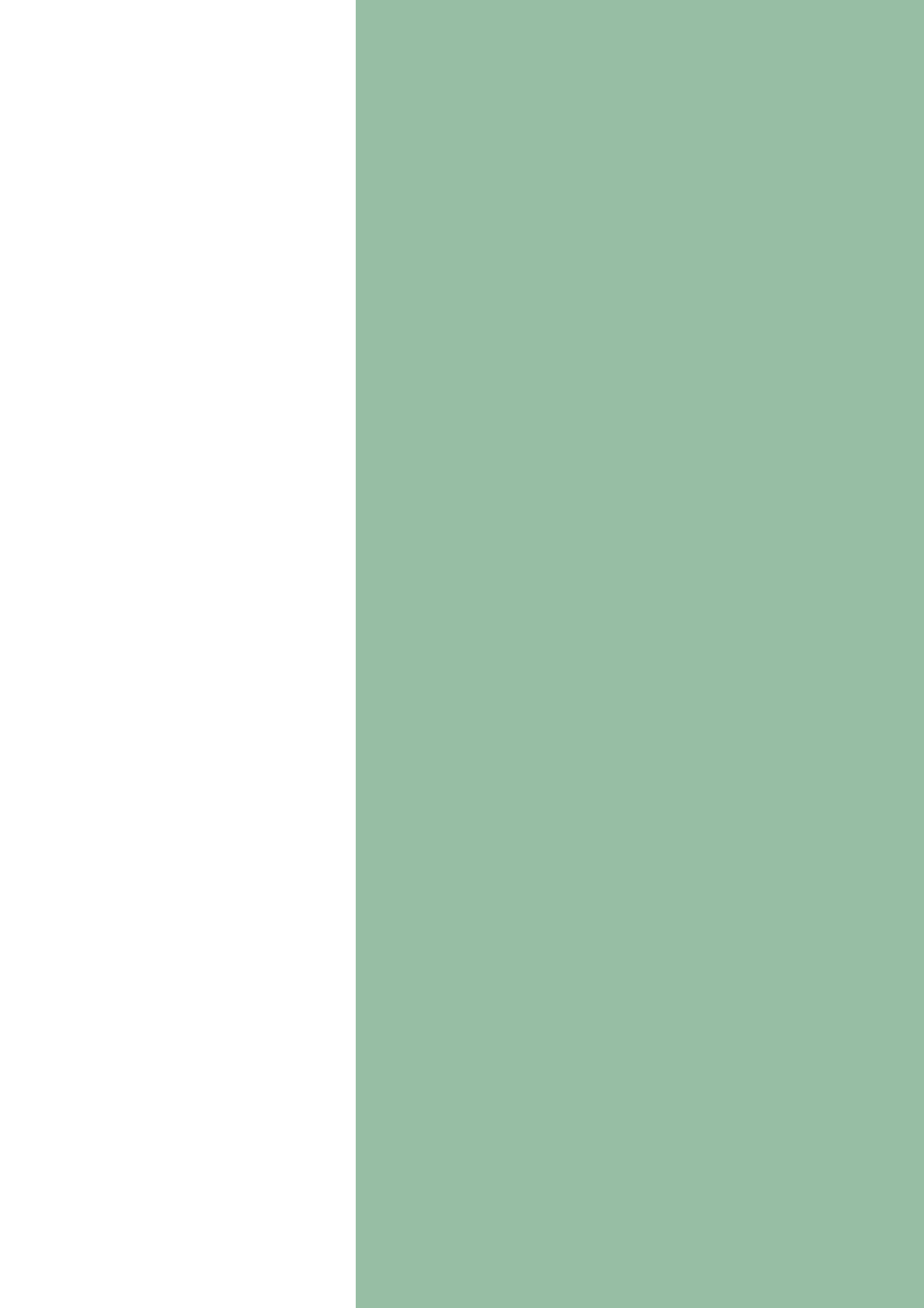



# The Secrets of Plastic Language Revealed

## Multimodality, Polysemiosis, and Iconicity

Göran Sonesson

### Abstract

The notion of “plastic language” (or, as we will say in the following, the plastic layer) of the picture goes back to French structuralism, where it was supposed, just like “iconic language”, to be fundamentally based on arbitrary conventions. Nobody nowadays takes seriously the idea of depiction being purely conventional, but we will argue that the same counterclaim should be made with regard to the plastic layer of the picture. The *Ganzheitspsychologie* of the early 20<sup>th</sup> century, notably that of the Leipzig School, offered fruitful ideas on how to analyze plastic meanings, as did their later followers in the United States, such as Rudolf Arnheim, on one hand, and Heinz Wellek and Bernard Warren, on the other. It is, however, the rather anecdotic evidence presented by Wolfgang Köhler, a member of the more well-known Berlin school of *Ganzheitspsychologie*, customarily known as *Gestalt* psychology, which was taken up more recently by V. S. Ramachandran, and applied in a more systematic way by Felix Ahlner and Jordan Zlatev, which paves the way for a serious study of plastic meanings. In this paper, I try to show that, in semiotic terms, plastic meanings tend to manifest secondary iconicity, which means that they have a rich, but indeterminate, potential for similarity, the meaning of which can only be fixed using structural oppositions, and more precisely, proportionalities, that is, relations between two pairs of opposed terms. From the point of view of the indeterminacy of iconic meaning, the plastic layer of pictures is similar to doodles, which, however, manifest this indeterminacy on the level of depiction, and their meaning are usually settled by the means of labels. Doodles differ from pictures, in the narrow sense, which rely on primary iconicity, and thus convey a determinate meaning on their own precisely on the level of depiction.

## Introduction

It is impossible to determine, at present, who first invented the distinction between “the plastic language” and “the iconic language” of a picture, whether it was Jean-Marie Floch (1986), of the Greimas school, or the notorious Groupe  $\mu$  (1992), but Floch certainly gave the best description extant of plastic language, as the way of considering a picture, in the everyday sense of the term, as if it were an example of nonfigurative art. Nonetheless, there are two terminological problems, which are at least partly conceptual, and a third more fundamental issue which does at least in part results from the latter problems. First, it may be better to talk about layers of meaning, rather than languages, since we are not concerned with anything resembling spoken (or written) language. Second, it is seriously misleading to call the depictive layer of the picture iconic, since iconicity is a much wider notion, including all kinds of similarity, even of the most generic kind. Third, there is every reason to think, contrary to what is taken for granted by both Groupe  $\mu$  and Floch, that meanings of the plastic layer are preponderantly iconic, whether based on similarity within a specific sense modality, or on correspondences between the senses.

Before proceeding, it is urgent to clear up some of the mess resulting from the current use of the term multimodality. We can derive some secours from the distinction proposed by some of my close colleagues (Louhema et al. 2019; Stampoulidis, Bolognesi, and Zlatev 2019) between multimodality in a narrow sense, as involving different senses, such as visuality, audition, tact, etc., and polysemiosis, in the sense of distinct semiotic systems, which, for instance, accounts for the difference between pictures, gesture, and written language, which are all ordinarily conveyed by visuality. There may in fact be more issues involved in the current notion of multimodality than can be covered by these two distinctions, but, in the following, I will attend to the difference between multimodality and polysemiosis. No doubt, the separation between the Peircean categories of iconicity, indexicality, and symbolicity, is often also taken to be part of multimodality. Nevertheless, iconicity, as indeed indexicality and symbolicity, clearly spans the distinction between sense modalities and polysemiosis.



## The Plastic and Pictorial Layers of the Picture

Since the final decades of the last century, there has been something of a consensus in pictorial semiotics, according to which standard pictorial signs can be divided into two layers: the iconic function, which is thought to be the features by means of which the picture depicts one thing or another, normally corresponding to a fragment of a scene as perceived in real experience; and the plastic function, which is the meaning conveyed by the picture as a surface on which colour spots are disposed in a particular way, i.e. the picture considered as it if had been a piece of abstract art. Indeed, as Jean-Marie Floch (1986) points out, studying the plastic function of any picture amounts to treating figurative pictures as being “non-figurative”, in the sense in which “figurative” means depicting. Something that is, on one level, a sun, or a flower, and even a human body huddled together, Groupe  $\mu$  (1992) chimes in, may on another level appear as a circle or another roundish shape.

To reduce iconicity to the illusion of seeing a scene from the real world, as given in direct perception, is, of course, quite contrary to Peirce’s definition, which embraces all kinds of similarity. While what is here called the iconic layer connects relatively concrete expressions and contents corresponding to familiar objects within the individually perceptible world of our experience, the plastic layer uses shapes the properties of which are abstract, to convey to us meanings usually at even higher levels of abstraction (“roundness” for “nature”, etc.). In this sense, the latter may well be iconic, to the extent that they are synesthetic and/or physiognomic, which is part of the secret of abstract art. To avoid confusion, however, it is important not to use the same term for two notions which do not have to coincide: we use the term “pictorial function” to epitomize the rendering of perceptual appearances, while opposing it to the plastic function which has to do with the meanings of shapes and colours. The pictorial function is always iconic, but there are also other types of iconicity, some of which are characteristic of the plastic layer.

The classical Greimas school was wedded to the proposition that all meanings had to be conventional. I have abundantly discussed elsewhere the antinomies produced by this proposition in the case of the pictorial level (Sonesson 1989, 1994b, 2008, 2015a). But, if the plastic level is also conventional, the question becomes how we will be able to discover its meanings. Floch (1981) sets out to do this in his analysis of Kandinsky’s *Composition IV* (Fig. 1).<sup>1</sup> Not even the structuralist principle of binary contrasts, on which Floch relies, is sufficient to tell us how to find the first element of the pair, as I have pointed out elsewhere (Sonesson 1987, 1989, 152): once we have A, we can find non-A, but that leaves us with the problem of finding A. This first phase must therefore remain intuitive.

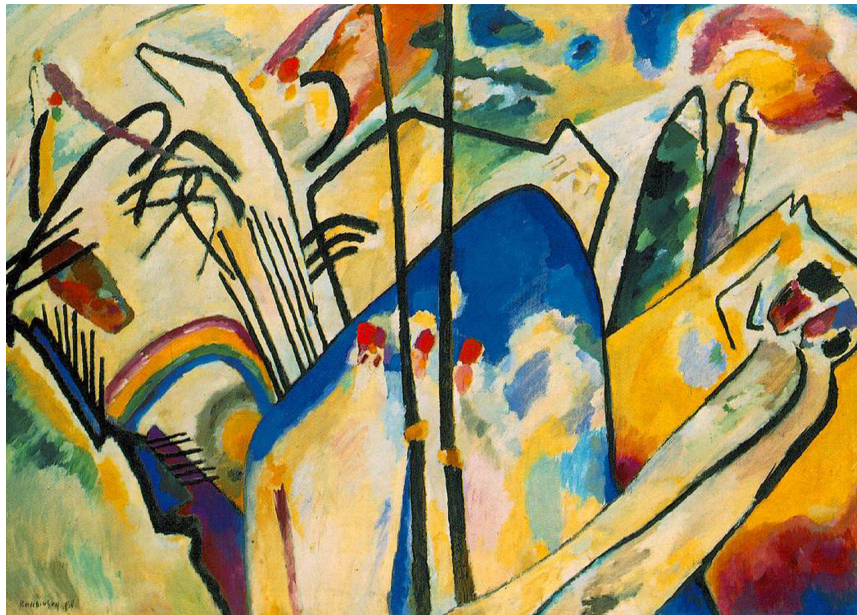

Figure 1. Wassily Kandinsky, *Composition IV*, 1911, oil on canvas, 159,5 x 250,5 cm, Kunstsammlung Nordrhein-Westfalen, Düsseldorf, Copyright: U.S. public domain.

In the specific case of Kandinsky's *Composition IV*, Floch aims to discover the meanings expressed in this abstract piece of work by scrutinizing other works of Kandinsky made more or less at the same time, in which he deems the plastic layer to be more or less similar to that of *Composition IV*, and which happen to be figurative paintings, that is, they come closer to represent objects of the real world, and they have titles saying something about their content.<sup>2</sup> Sometimes, Floch (1981, 145) goes beyond this principle to pay attention also to the particular context: the light area in the middle field of *Composition IV* should only be compared to other light fields also found below dark, bluish masses. Thus, while Floch is supposedly searching for the content plane of the plastic layer, he actually is all the time concerned with the content plane of, in his terms, the iconic language (our pictorial layer), because he presupposes, instead of demonstrating, that they must be identical.

But why should we bother to analyse the plastic layer if what it tells us is anyhow the same thing that the iconic language tells us, and in fuller detail? While Floch is perhaps not aware of this problem, there seems to be at least one interpretation which makes this procedure worthwhile: perhaps different artists will correlate the plastic and the pictorial layers in different ways, so that the correlation itself becomes significant. For instance, using the same plastic shape for a captive princess, a person in a fight, a woman holding her chin, etc., Kandinsky seems to

suggest that they have something in common, i.e., he creates a new category that no other artist would have used. Now, if we can attribute specific meanings to the figures on the plastic layer, the correlation between the plastic layer and the pictorial layer may tell us something worth considering about some pictures as opposed to others, for instance, about Kandinsky's pictures, which would not be true of all other pictures. Elsewhere, I have tried to show that something like this holds true of the work of Rothko, relying on plastic meanings which are fairly well established, such as those of roundness and angularity (Sonesson 1994a, 2014). However, most plastic meanings are so far unaccounted for, and need to be established by experiments, in the tradition of what has already been done by Gestalt psychologists, as well as by René Lindekens (1976) and Hartmut Espe (1983), who however, in concord with the spirit of the age, take for granted that these meanings are conventional. But we can already conclude that the way in which meaning is conveyed by the pictorial and the plastic layer of the picture pertain to different kinds of polysemiotic systems, while being, so far, addressed to the same sense modality, *visuality*. We will understand more about this difference, after we have explored the notions of primary and secondary iconicity.

## The Two Brands of Iconicity

In many of my papers, I have discussed the notion of iconicity, in the sense suggested by Charles Sanders Peirce (Sonesson 1989, 1994b, 1998, 2008, 2016), which is to be distinguished, to begin with, from the meaning of terms such as orthodox icon, iconic codes (in cognitive science), computer icons, cultural icons, and, last but not least, from the idea of producing an illusion of seeing a scene cut out from perceptual reality. It is the latter notion which figures in the definition of iconicity within the Greimas school and the work of Groupe  $\mu$ . No doubt this is a kind of iconicity, but it is by far not the only one extant. Once such potential misunderstandings have been cleared up, we have to start the real work, which consists in trying to find out what Peirce really meant by the term—and to determine if, thus understood, this notion is susceptible of contributing to the advance of semiotic inquiry.

It should be clear that, in Peirce's system, iconicity does not, as such, stand for similarity. Elsewhere I have made use of some terminology, which Peirce seems to have abandoned rapidly, but which I think contributes hugely to clarify the issues (Sonesson 2013b). Comparing Peirce's different definitions, I have suggested that, as an instance of one of the three Peircean categories, Firstness,

iconicity can be paraphrased as “something there.” If we add Secondness to such a Firstness, we arrive at a relation, that is, a ground, which, as long as we are still concerned with iconicity connects two instances of Firstness, which can be considered a kind of similarity. Accordingly, we can paraphrase it as “something connected.” But to arrive at a similarity which is also a sign, we need to enter into Thirdness, which, in this case, means the sign function. Since there must be more to Thirdness than the sign function (which Peirce at least sometimes admits), its proper paraphrase is “something reflected upon.”

Everything hinges on what this “something there” is. If we think about our most common everyday experience, that is, what Husserl terms the experience of the Lifeworld, what is immediately given to us is the thing presented from a peculiar perspective and in a particular environment, that is, in Husserlean terms, a noema. This seems to concord with the interpretation of Peirce’s *quale* offered by Marc Champagne (2018, 38ff). Nevertheless, there are too many passages in Peirce’s writings which suggests that analytical philosophers are more correct in understanding this term coined by Peirce as standing for sense data. This would seem to make iconicity into a kind of non-configurational whole, in the sense first defined by Felix Krueger (as cited by André Wellek in Weinhandl 1960, 385), the original master of the Leipzig Branch of *Ganzheitspsychology*, less familiar to us than the Berlin branch, with such representatives as Köhler, Koffka, and Wertheimer, who made a certain impact in the United States. Indeed, according to the Leipzig School, all wholes (*Ganzheiten*) are oversummative, that is, they are perceived as being something more than their parts, but only configurations (*Gestalten*) are transposable. Emotions, as well as the experiences of small children, are non-configurational wholes. It will help in the following to think of iconicity as an instance of such a non-configurational whole.

An iconic sign is only such, according to Peirce’s stipulation, if its iconicity is not only independent of the relationship between the things involved, as is also the case with indexical signs with respect to indexicality, but the independence, in the sense in which Peirce uses this term,<sup>3</sup> must also obtain between the respective iconicities of the things joined in the sign. If iconicity is simply the (list of) properties of the things concerned, then those properties must certainly inhere in the two things independently.

The case of the relation between the two things, that is, the ground, is different, as I have argued elsewhere. If we want to account for all kinds of signs, and, in this specific case, for all varieties of iconic signs, we have to admit that there are cases in which the iconic ground is not independent of the sign function. I have suggested that we have to distinguish primary iconic signs, in which the perceived similarity between the two things (the ground) is a least part of the reason for positing a sign function, and secondary iconic signs, where, on the contrary, it is

the perception of the sign function which leads us to posit the iconic ground. The picture, to the extent that it depicts something, is clearly an instance of primary iconicity. The plastic layer of the picture, however, is more likely to pertain to secondary iconicity. Secondary iconicity, as I have characterized it elsewhere, simply means that there is indeed a virtual iconic ground, but that the sign character remains indeterminate. This may be so, either because the iconicity is so completely realized, as to suggest that we are rather concerned with an item of the category of things involved, as for instance, the car, not on the road, but at the car show—or because the similarity remains as indefinite and abundant that something is needed to fix its meaning. The latter no doubt applies to the plastic layer of the picture.

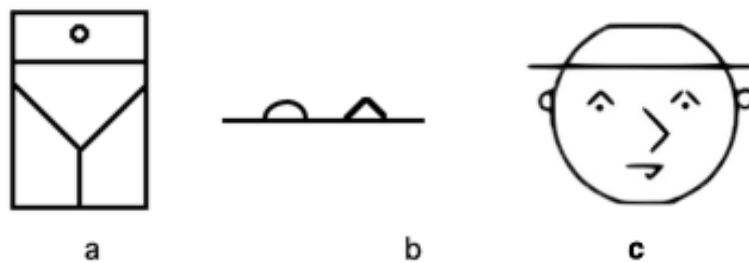

Figure 2. Two doodles and a picture which can be read as a doodle: a. Olive dropping into Martini glass or Close-up of a girl in a scanty bathing suit (inspired from Arnheim as adapted in Sonesson 1992a). b. Carracci's key (Mason behind wall); c. face or jar (inspired by Hermerén 1983, 101). This and all following figures (except Figures 1 and 7, which are in the public domain) were designed by the author.

The difference between primary iconicity, epitomized by pictures, and secondary iconicity, exemplified by doodles, which require a key, can be spelled out by comparing Arnheim's (1969, 92f) figure which can represent "Olive dropping into Martini glass or Close-up of a girl in scanty bathing suit", and no doubt many other things (Fig. 2a), as well as Carracci's mason behind a wall (Fig. 2b), to the face in figure 1c. According to Göran Hermerén (1983, 101), it is only because of "the limitations of human imagination" that we see the latter as a human face, for it can equally well be perceived as "a jar from above, with some pebbles and broken matches on the bottom, and a stick placed across the opening". That is, Hermerén treats it as a doodle. In fact, Gestalt principles, the face as a privileged perceptual object (Eleanor Gibson 1969, 347 ff.), and so on, all conspire to make one of the readings determined. While it is possible to find the elements Hermerén suggests should be there in the picture, it is impossible to see them without the primary interpretation of the figure as a face disturbing this interpretation. Thus, it seems that when an expression has similarities to different contents or referents,

one of these may be favoured because of properties of the expression itself and is not overridden by convention. An example of the opposite confusion is found when Erik von Däniken (1979) points to prehistoric pictures supposedly showing what nowadays could be seen as wristwatches, thus testifying to the presence of visitors from other more advanced civilizations already as far back in the past as when the pictures were made (Fig. 3b). What von Däniken describes as wristwatches are really doodles, that is, cases of secondary iconicity: it is our knowledge of a world in which there are wristwatches which suggests this specific interpretation. A more complex example is offered by the Maya Glyph for the god of writing, which takes the shape of a rabbit (Fig. 3c). Given the context of Maya civilization, we know that the rabbit is incising letters on a stone tablet. I have been using this glyph for a long time already as a signature, because, in contemporary culture, it could easily be interpreted as the rabbit using a portable computer. But we do not confuse the rabbit with something else (although we do not necessarily know that the rabbit is the Maya god of writing). The rabbit is a case of primary iconicity, while the stone tablet/computer only can be made sense of thanks to secondary iconicity. In this case, the part of primary and secondary iconicity in the drawing is clearly separate. But it can also be said about Anati's so-called prayer (Fig. 3a), that it is primary iconicity for a human being, but only (possibly) a secondary iconicity for a person making his prayers. Of course, in the same sense, the rabbit is only on a secondary reading the God of writing, but then this secondary interpretation seems to function more in symbolic, than in iconic terms.

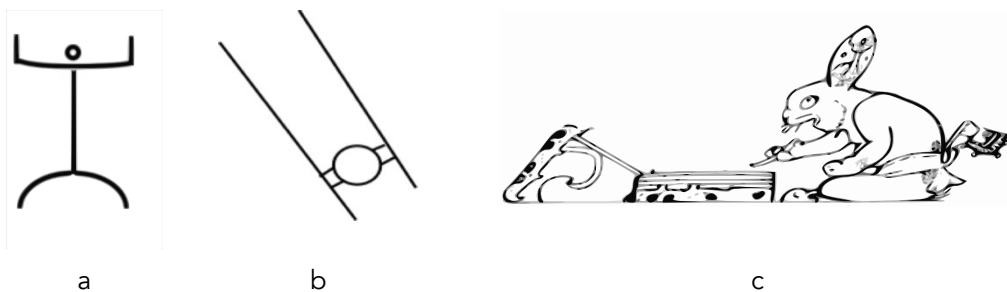

Figure 3 a. Anati's "prayer" (see Anati 1976; Sonesson 1994b); b. Prehistoric watch, according to von Däniken (1979); c. The Mayan Glyph for the rabbit-God of writing.

## The Iconic Sources of Plastic Meaning

Elsewhere, I have discussed the important contributions to the study of plastic meanings offered by the different branches of *Ganzheitspsychology*, and in particular, of the Leipzig School, initiated by Felix Krueger. Although these ideas were explored experimentally by Friedrich Sander and Hans Volkert (1962), as well as, as is more generally known, by Heinz Werner and Bernard Kaplan (1963), and by Rudolf Arnheim (1969), one cannot help feeling that the theory remains very much in advance on the empirical evidence (Sonesson 2004, 2013a, 2015b, 2012).

It will be remembered that, according to the summary of the results of the Leipzig School made by André Wellek, all wholes are oversummative, that is, they are perceived as being something more than their parts, but only configurations are transposable. Adopting additional criteria suggested by Sander & Volkelt (1962, 43ff), I have proposed that the wholeness as such, i.e., the general theme, could indeed be transposed. According to Volkelt, a typical configuration stands out from a background and is internally articulated (*gegliedert*), but other holistic properties may well be externally and internally diffuse (*aussen und binnendiffus*). In his studies of children's drawings, Volkelt comes upon holistic properties, more obviously so than emotions, which are non-configurational, for instance the closure and angularity of the cube. In this and similar drawings, non-configurational, holistic properties like angularity and closure, I have suggested (Sonesson 1989, 81ff, 2004, 2013a, 2015b, 2012), have been transposed, contrary to Wellek's claim; the more specific, inner and outer organization is, of course, not transposed. The newly learned melody is, in that respect, a less extreme example. Volkelt and Sander recognize many degrees of demarcation (*Absetzlichkeit*) and articulation (*Gegliedertheit*). The typical configuration occupies a middle position between diffuseness (*Diffusität*) and dismemberment (*Zerstücktheit*), Volkelt (1962, 45) observes. Later, however, he claims these are two different scales, chaos being both diffuse and dismembered. If so, becoming more diffuse, a percept does not have to become less dismembered, and vice versa. Extreme diffuseness, Sander says (1962, 77), produces a non-configurational whole, the extreme case of dismemberment being the breaking up of a whole into many separate objects. But the multiplication of parts in a configuration will never lead to its dismemberment, because the multiplicity and the unity will grow simultaneously (45). If so, there clearly must be two scales, and a configuration requires a relatively low degree of dismemberment as well as diffuseness.



Many examples similar to the ones considered above are found in the work of Werner and Kaplan (1963, 205 ff., 337 ff.): their “linear names,” notably, are such non-configurational holistic properties that can be transposed in some limited sense of the term.

As I have done elsewhere, I would like to highlight, in this context, a little-known study by Lotte Hoffman (1943), the research paradigm of which, as far as I know, nobody has pursued further since her time, although the empirical results lend themselves to interesting interpretations. The task assigned by Hoffman to the children in this study was to reproduce a series of simple figures, with the help of some elementary objects that could be combined in different ways. The choice of the children was thus limited by the assortment of elements offered, but, whatever one may think about this limitation, the fact that the responses of the children differed with age would seem to suggest that this experimental layout has captured some important differences. The circle turned out to be the shape used by the children when there was no correlation whatsoever between the model and the figure created, i.e., to represent ‘any object whatsoever’, that is, as pure iconicity or as a non-configurational holistic property. Nevertheless, it also reappears later, when other shapes to which it is opposed have been isolated, to represent roundness, in opposition to what is straight, stiff, or angular. At this stage, the circle, as an ideally round object, becomes the exponent of any object containing an element of roundness (Fig. 4). This seems a promising result, but if we are going to get any further, more studies using this paradigm are necessary.

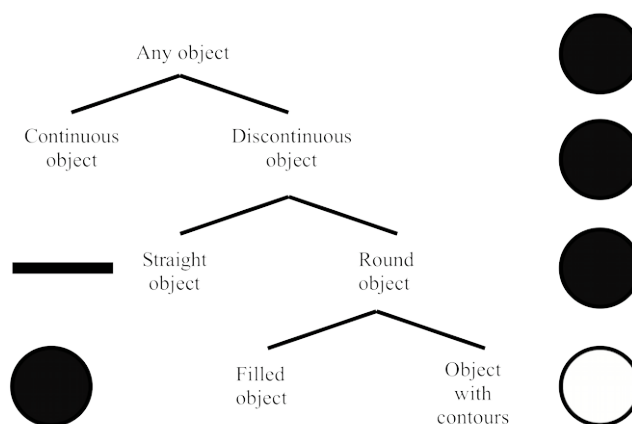

Figure 4. The graphic hierarchy of prototypes, as derived from Hoffman’s work in Sonesson 1989.

This is the sense in which we may say that, at the start, the plastic and the pictorial layers of the picture are not differentiated. Hoffman's children are trying to create equivalents of what they observe, at least when they go beyond 'the object whatsoever.' Their understanding of what is going on is therefore pictorial, but for the addressee, only the plastic meanings are available. This may also be true, as I have pointed out elsewhere (Sonesson 1987, 1994a, 2014) of classical "abstract" paintings, such as those produced by Kandinsky and Rothko.

Werner & Kaplan (1963, 85ff) refer to Piaget's idea of a sensory-motor stage, but, remarkably, they claim that his observations show the pervasive presence of "dynamic-vectorial qualities" such as "direction, force, balance, rhythm, and enclosingness"—properties which are, in part at least, well known to us from topology. What seems to be lacking here is a clear idea of the difference between Piaget's focus and that of Werner & Kaplan. To imitate the opening and closing of eyes by opening and closing one's hands, as in the case quoted by Werner & Kaplan from Piaget, is certainly to attend to figurative properties, but figurativity is essentially a residue concept to Piaget, who is interested in operativity. Just as, according to Piaget, conceptual schemas are abstracted from actions through the many stages of intellectual development, physiognomic properties could also be conceived to take their origin in the actions of one's own body, yet remaining bound up with the body in all their further applications as being the deeper source of their sense.

According to Piaget (1970, 41), "abstraction from the object" permits us to discover the properties of the thing itself, as is the case in the natural sciences, whereas "abstraction from action" starts out from coordinations that are not present in the things themselves, but are added by the particular handling of the object in action. Classification, and even perception itself, to the extent that it gives rise to correct judgment, are to Piaget results of the actions effected by the subject on the object in order to change it, or to change its position. Thus, abstraction from the object accounts for the contents of the sciences, as distinguished from their conceptual framework, and seems to be of no relevance to the activities in the normal social Lifeworld. However, there is a trace of generality, as distinguished from generalization, in the figurative aspects, opposed by the later Piaget to the operative ones. This may be because we do not ordinarily live in the world of the natural sciences, but in the Lifeworld, the world taken for granted. Figurativity, then, would seem to be the imprint of activities to which we submit the world, i.e., a kind of "abstraction from action," though not at the level of the "idealised" practise of the sciences, but of the Lifeworld: the "habits" of Peirce and the "ways things tend to behave" of Husserl.

In the exercise of the cognitive function, according to Piaget (1970), figurative aspects are subordinated to the operative ones, because the former will only acquire meaning when related by transformations. Operativity goes beyond figurativity, since there is no way of rendering it entirely by figurative means, but on the other hand, no thinking is possible without some figurative support. If Piaget's last-mentioned observation is taken seriously, it would seem to imply that figurativity cannot be completely rendered by operative means either. Thus, operativity and figurativity presuppose each other.

### Synaesthetic Meanings and Multimodality

Despite his allegiance to the Greimasean consensus, according to which all meaning is conventional, Jean-Marie Floch (1986), in his exemplary analysis of the advertisement for the cigarette brand "News," explores the parallel between the phonetic properties of the slogan and the arrangement of the corresponding picture. But this only makes sense if the relation between the slogan and the pictorial presentation is iconic (and, as we will see below, synaesthetic). That is, it supposes there to be a transposition of the non-configural holistic properties from the verbally formulated slogan to the layout of the pictorial elements, or the reverse. However, the most famous study of the transposition of non-configurational holistic properties being transposed, without using these terms, is due to Wolfgang Köhler (1930), whose analysis of the distinction between "maluma" and "takete" (Fig. 5) and the corresponding drawings has more recently been replicated by Ramachandran and Hubbard (2001) under better controlled circumstances, using the examples "bouba" and "kiki".

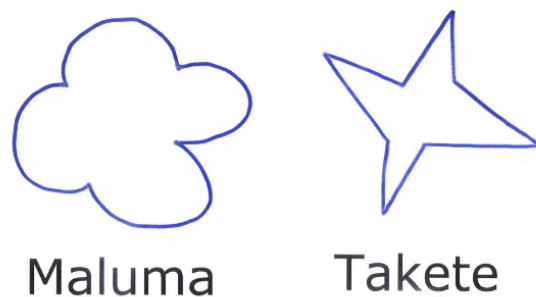

Figure 5. Maluma and Takete according to Wolfgang Köhler (1930), as reproduced in Sonesson (1989, 168).

Taking their point of departure in the work of Ramachandran and Hubbard, Ahlner and Zlatev (2010) realized a more systematic study, presenting the visual shapes labelled “bouba” and “kiki,” together with variations of the corresponding syllables, involving both the consonants and the vowels. Thus, the figures were compared with a) two words with different vowels, but the same sonorant consonant, for example, lili vs. lulu; b) two words with different consonants, but with the same vowel [i], for example, kiki vs. nini; c) incongruent combinations: a word with a “hard” consonant and “round” vowel contrasted with a word with a “soft” consonant and “sharp” vowel, for example, tutu vs. lili; d) congruent combinations: a word with a “hard” consonant and a “sharp” vowel contrasted with a word with “soft” consonant and “round” vowel, for example, titi vs. lulu. As it turned out, not only were all the correlations significant, but both vowels and consonants were highly relevant for the result. This clearly implies that iconic properties are transposable, in the sense of the Leipzig School, between different sense modalities. That which makes these properties transposable is no doubt synaesthesia, which is a rather abstract kind of iconicity. This must be a species of multimodality, although, in this case, the different senses are not merely being experienced concurrently, but are made to correspond to each other on a higher level of iconicity.

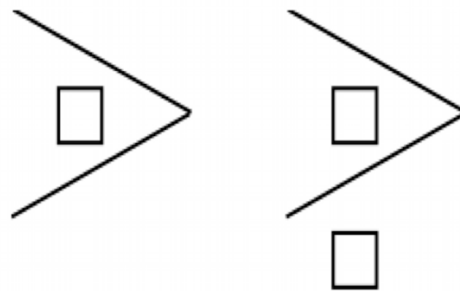

Figure 6. Structure and configuration: a. configuration without structure;  
b. configuration with structure (Sonesson 2012).

Synaesthesia is clearly a case of secondary iconicity. The meaning conveyed is dense and replete, but it is also highly indeterminate. One way of setting the panoply of meanings is, as in the case of doodles, to add a label. But the label works differently from the case of doodles, since the meaning imparted relies, not on the verbal content of the linguistic item (which is normally non-existent), but on its “plastic” layer. Even so, it is not certain that this is sufficient to settle the potential of meaning.

What Köhler, Ramachandran, and Ahlner and Zlatev all offer is a proportionality, that is a relation between relations, according to which A is to B as C is to D. Such a formula supposes there to be a similarity on a rather high level of abstraction, between the relations which A entertains to B as compared to the relations C entertains to D. This is a structure in the sense of linguistic structuralism, which is very different from the notion of Gestalt, (configuration) which, unfortunately, has often been rendered by the same word (Fig. 6). In a configuration, the meaning of the parts is resolved into the whole, while, on the contrary, in a structure, it is the whole which imparts meaning to the parts.

Indeed, from the interaction of the configuration and the structure, complex meanings may be derived. Groupe  $\mu$  (1992, 352f) tells us that the waves and Mount Fuji in Hokusai's *The Great Wave off Kanagawa* (Fig. 7) are seen as different when they are interpreted as such, but on the plastic layer, they are identified because of the similarity of their triangular shape, both having the point turned upwards, and of their colour, which is blue stained with white spots. From our point of view, it might be added that the waves as well as the mountain immediately form configurations in perception, while the organization of the picture makes the structural relation between one of the waves and the mountain stand out. This should serve to make the difference between structure and configuration clear.



Figure 7. Katsushika Hokusai, *The Great Wave off Kanagawa*, 1830-32, color woodcut, 25,7 x 37,9 cm, MoMA, New York, Copyright: U.S. public domain.

## Structure and Meaning

I introduced the notion of resemantization to account for the illusion of structuralist semiotics that the meaning of pictures was in some way similar to that of language, while at the same time demonstrating the difference. All (verbal) languages obey a principle which has variously been denominated "double articulation" and "the duality of patterning", according to which any sentence can be divided into words (morphemes, monemes), which have (relatively) independent meanings, and then further into speech sounds (phonemes or graphemes), which do not have any meaning of their own, but which serve to distinguish meanings (e.g. g substituted for c makes the difference between "gold" and "cold"). In the case of pictures, we can also make a distinction between a configuration which has a meaning of its own, and constellations of lines and shapes which are meaningless, without referring to the context, but, unlike what happens in language, there is no predetermined level on which this distinction occurs, instead depending on the genre and the style of depiction. But this is not the essential difference. If we think of the word, in Gestaltist terms, as a whole that is more than its parts, then this formula applies in a different way to pictures. Once you put the graphemes "f", "a", "c" and "e", together, you obtain that word "face." When you refer the different squiggles you perceive to the whole of which they are a part, the meaning of the whole is not only "face", but the different parts take on the partial meanings of "nose," "eyes," "mouth," etc. This is very different from the case of language. Unlike language, both pictures and doodles may be considered to go through the process of resemantization, but they do so in different ways (Fig. 8).

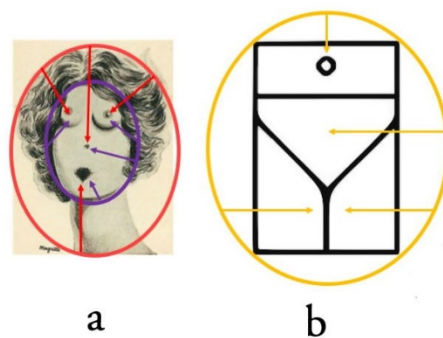

Figure 8. Resemanticization of a picture (a) and of a doodle (b).

While the doodle (b) is a clear case of top-down processing starting out from a label, the picture (a) requires a complicated interplay of top-down and bottom-up perception, which is particularly clear in this case (Magritte's *Le viol*), since the borders of the pictures may be set in two different ways (the body, or the face including the hair).

Structuralism, in the sense given to this term in France at the middle of the last century, wanted to reduce all kinds of semiosis to structure. Even those who were not, like me, early combatants in the battle against structuralist reductionism, seem to have recognized by now (though rarely in explicit terms) that structure cannot account for all kinds of meaning. But this does not mean that structures do not produce meaning, nor that this kind of meaning only exists in language. Structure may be primary in the production of meaning in language but, in the case of other semiotic resources, it intervenes on a secondary level. In Sonesson (1989, 76ff), I discussed the case of an advertisement for a mark of stockings, in which the man and the woman, and all their properties, could be easily observed without any further instruction. However, the argument of the advertisement could only be grasped by an audience that was familiar with the Marilyn Monroe film, *The seven-year itch* (1955), and that could realize that, in the advertisement, the parts of the man and the woman had been inverted. This is a structural opposition, which is not primary, because the picture as such can be perceived without taking any structure into account, but which is still important for the function of the picture as used in the advertisement. It is, however, a secondary strategy applied to the interpretation of the content, and now we are interested in the intrinsic properties of the expression, that, in terms of classical semiotics, the plastic layer of the sign.

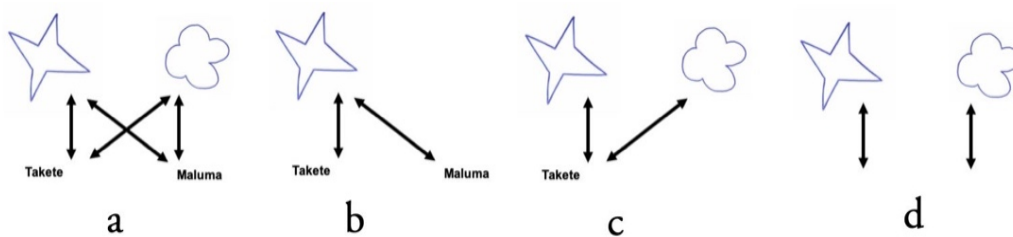

Figure 9. The Köhler (1930) meanings of these figures are most pregnant when there is a proportionality, involving four elements (a). Any combination of three of the elements of such a proportionality (e.g., b and c) may be of assistance, as may, as a limiting case, two elements (e.g., d), but one element only is hardly sufficient.



What we have in the case of Maluma vs Takete is precisely structure, or more particularly, structure upon structure, as in Lévi-Strauss' (1958) notion of proportionality: not only A vs B, but  $A : B :: C : D$ . That is, the phonetic sequences 'Takete' is to the angular figure as the phonetic sequences 'Maluma' is to the roundish figure. The Köhler (1930) meanings of these figures are most pregnant when there is a proportionality, involving four elements (a in Fig. 9). Any combination of three of the elements of such a proportionately (e.g., b and c) may be of assistance, as may, as a limiting case, two elements (e.g., d), but one element only is hardly sufficient. This is very different from the case of another kind of visual configuration with unclear meaning, that is, the doodle (Fig. 10).

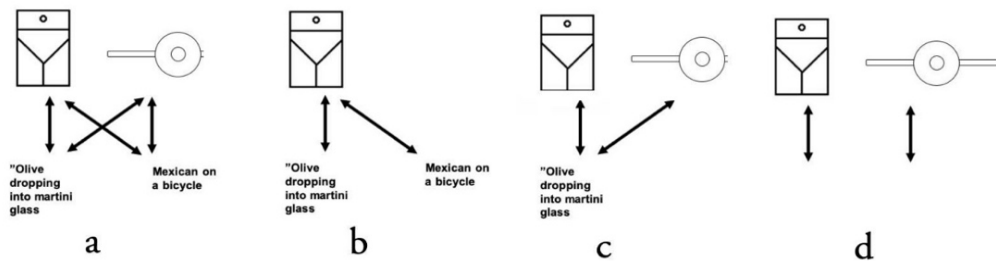

Figure 10. Similar structurations as those in figure 9 but applied to doodles. Here version (d) is insufficient to engender a meaning, but (a-c) would seem to offer more than is required.

Doodles and Maluma-Takete types of figures are similar in that they contain an iconic potential that is lost if no other determination is supplied. The fundamental idea behind the notion of secondary iconicity, as opposed to pure convention, is that there is, beforehand, a potential iconicity, but that it needs to be determined in some way, by means of labels, context, or structure. Doodles are determined by labels, and once the label is set, doodles work in a way which is similar to pictures, that is, the meaning of the whole is redistributed to the parts, which take on different meanings as parts of the whole which is projected onto them. The Maluma-Takete types of figures are determined by structural oppositions, but these oppositions do not lead to any general redistribution of meaning to the parts but, instead, attribute a single (but fuzzy) property to the figure as a whole, that is, in our case, either of roundishness (and its associated meanings) or angularity (and its associated meanings).



## Conclusion

Structuralism, whether it was that of the Greimas school or of the Belgian Groupe  $\mu$ , very much advanced our understanding of the way pictures mean by distinguishing (in our terms) the pictorial and the plastic layers of their meanings. Further inquiry was blocked, nevertheless, by the taken-for-granted axiom that all meaning was conventional. Relying on my own earlier work, but also of the suggestions of the Leipzig School of *Ganzheitspsychology* of the early 20<sup>th</sup> century, as well as a number of experimental studies, some accomplished at the time, and some more recent, I have tried to bring the theoretical argument further. There can be no doubt, nevertheless, that any further insight into these issues is depending on a renewal of the research paradigm of Köhler-Ramachandran, and, in particular, that of Hoffman. Although I have been involved in experimental works, as well as in theoretical considerations, as a professor emeritus I am reduced to dedicating myself to the second part. I can only hope that someone else will take up this line of inquiry, largely abandoned nowadays.

## Author Biography

**Göran Sonesson** is Professor Emeritus at the Division of cognitive semiotics at Lund University. He holds doctorates in general linguistics from Lund and in semiotics from Paris. He has published numerous papers, both theoretical and experimental, on pictorial, cultural, and cognitive semiotics, as well as on the semiotics of communication and translation and the evolutionary foundations of semiosis. Apart from anthologies, his papers have appeared in journals such as *Semiotica*, *Cognitive Semiotics*, *Cognitive Development*, *Sign System Studies*, *Degrés*, *Signa*, *Signata*, *Sign and Society*, *Frontier of Psychology*, etc. His main book-length works are *Pictorial Concepts* (1989), which is a critique of the critique of iconicity, and *Human Lifeworlds* (2016), which is a study in cultural evolution. His new book, *The Pictorial Extensions of Mind*, will be published next year by deGruyter. Mail: [goran.sonesson@semiotik.lu.se](mailto:goran.sonesson@semiotik.lu.se) ORCID: 0000-0003-2517-2397

## Notes

1. According to Greimas and Courtés (1979), the criteria which are to be used in the segmentation of texts comprise the exchange of acting persons, transitions in time and place and changes of emotional atmosphere. Unfortunately, these criteria only seem applicable to verbal texts, or perhaps to texts extended in both space and time, and Floch rightly ignores them. That seems to leave him with intuition alone, but he does have a kind of regulative principle, as we saw below, the idea that all relevant properties should form binary contrasts, and that many of those will join to form bundles of similarities.
2. It should be noted that Floch here takes for granted similarity, when it obtains between different perceptual experiences, and not between expression and content of the sign.
3. There are numerous ways in which things may be dependent or independent of each other, as I have noted elsewhere (Sonesson 2016), but here we shall simply go along with Peirce's use of the term.

## Bibliography

- Ahlner, Felix, and Jordan Zlatev. "Cross-modal iconicity: A cognitive semiotic approach to sound symbolism." *Sign Systems Studies* 38, 3–4 (2010): 298–348.  
<http://search.ebscohost.com/login.aspx?direct=true&db=a9h&AN=63194453&site=ehost-live>.
- Anati, Emmanuel. *Evolution and style in Camunian rock art*. *Archivi* 6. Capo di Ponte: Edizioni del Centro, 1976.
- Arnheim, Rudolf. *Visual thinking*. Berkeley: University of California Press, 1969.
- Champagne, Marc. *Consciousness and the philosophy of signs: how Peircean semiotics combines phenomenal qualia and practical effects*. Cham, Switzerland: Springer 2018.
- Däniken, Erich von. *Meine Welt in Bildern*. Ullstein, 1979.
- Espe, Hartmut. "Empirische Analyse visueller Zeichen: der Einfluss der Belichtungsdauer bei der Vergrössung auf die affektive Bedeutung von Schwarz-Weiss-Fotografien." In *Visuelle Kommunikation und/ oder verbale Kommunikation*, edited by Martin Krampen. Hildesheim & Berlin: Olms Verlag/Hochschule der Künste, 1983, 92–121.
- Floch, Jean-Marie. "Kandinsky: sémiotique d'un discours plastique non figuratif." *Communications* 34 (1981): 135–57.
- . *Petites mythologies de l'œil et de l'esprit : pour une sémiotique plastique*. Paris: Editions Hadès, 1986.
- Gibson, Eleanor J. *Principles of perceptual learning and development. The century psychology series, 99-0106191-1*. New York: Appleton-Century-Crofts, 1969.
- Greimas, Algirdas Julien, and Joseph Courtés. *Sémiotique: dictionnaire raisonné de la théorie du langage. Langue, linguistique, communication, 99-0126376-X*. Paris: Classiques Hachette, 1979.
- Groupe μ (Edeline, Francis, Jean-Marie Klinkenberg, and Philippe Minguet). *Traité du signe visuel: pour une rhétorique de l'image. La couleur des idées, 0993-684X*. Paris: Éd. du Seuil, 1992.
- Hermerén, Göran. *Aspects of aesthetics*. Lund: Liber Förlag/Gleerup, 1983.
- Hoffman, Lotte. *Vom schöpferischen Primitivganzen zur Gestalt*. München: Beck, 1943.
- Köhler, Wolfgang. *Gestalt psychology*. London: Bell and Sons, 1930.
- Lindekens, René. *Essai de sémiotique visuelle: le photographique, le filmique, le graphique*. Paris: Klincksieck, 1976.

- Louhema, Karoliina, Jordan Zlatev, Maria Graziano, and Joost van de Weijer. "Translating from monosemiotic to polysemiatic narratives: A study of Finnish speech and gestures." 47, 3–4 (2019): 480–525. <http://dx.doi.org/10.12697/SSS.2019.47.3-4.07>.
- Piaget, Jean. *Epistémologie des sciences de l'homme*. Paris: Gallimard, 1970.
- Ramachandran, V.S. , and E.M. Hubbard. "Synaesthesia—A Window into Perception, Thought and Language." *Journal of Consciousness Studies* 8, 12 (2001): 3–34.
- Sonesson, Göran. "Notes sur la macchia de Kandinsky. Le problème du langage plastique." *Actes Sémiotiques: le Bulletin X*, 44 (1987): 23–28.
- . 1989. *Pictorial concepts. Inquiries into the semiotic heritage and its relevance for the analysis of the visual world*. Lund University Press.
- . "Les rondeurs secrètes de la ligne droite. A propos de "Sans titre" de Rothko." *Les Nouveaux Actes Sémiotiques* 34-36 (1994a.): 41–76.
- . "Prolegomena to the semiotic analysis of prehistoric visual displays." *Semiotica* 100, 2-4 (1994a): 267–332. <http://dx.doi.org/10.1515/semi.1994.100.2-4.267>.
- . "That there are many kinds of pictorial signs." *VISIO* 3, 1 (1998): 33–54.
- . "Retour sur la matière du sens à l'ère de la production digitale." *VISIO* 9, 1-2 (2004): 215–234. <http://www.arthist.lu.se/kultsem/pdf/Retour.pdf>.
- . "Prologomena to a general theory of iconicity: considerations on language, gesture, and pictures." In *Naturalness and Iconicity in Language*, edited by Klaus Willems and Ludovic De Cuyper. John Benjamins Publishing Company, 2008, 47–72.
- . "The meanings of structuralism: considerations on structures and Gestalten, with particular attention to the masks of Levi-Strauss." *Segni e comprensione* XXVI 78 (2012): 84–101.
- . "Aspects of 'physiognomic depiction' in pictures. From macchia to microgenesis." *Culture and Psychology* 19, 4 (2013a): 533–47.
- . "The natural history of branching: approaches to the phenomenology of firstness, secondness, and thirdness." *Signs and Society* 1, 2 (2013b): 297–326.
- . "The cognitive semiotics of the picture sign." In *Visual Communication*, edited by David Machin, 23–50. Berlin: De Gruyter, 2014.
- . "The mirror in-between picture and mind: A phenomenologically inspired approach to cognitive semiotics." *Chinese Semiotic Studies* 11:2, 2 (2015a): 159–80. <http://dx.doi.org/10.1515/css-2015-0009>.
- . "Signs and Gestalten. From Visual Thinking to Pictorial Concepts." *Gestalt Theory* 37, 3 (2015b): 257–72.
- . "The phenomenological semiotics of iconicity and pictoriality - including some replies to my critics." *Language and Semiotic Studies* 2, 2 (2016): 1–73. [http://lass.suda.edu.cn/upload/day\\_160707/201607071053537646.pdf](http://lass.suda.edu.cn/upload/day_160707/201607071053537646.pdf).
- Stampoulidis, Georgios, Marianna Bolognesi, and Jordan Zlatev. "Metaphors on the cross-roads: A cognitive-semiotic framework to the study of Greek street art." In *The Creative Power of Metaphor*. Oxford, 2019.
- Weinhandl, F., ed. *Gestalthaftes Sehen. Zum hundertjährigen Geburtstag von Christian von Ehrenfels*. Darmstadt: Wissenschaftliches Buchgesellschaft, 1960.
- Werner, Heinz, and Bernard Kaplan. *Symbol formation: an organismic-developmental approach to language and the expression of thought*. New Yoek: Wiley, 1963.

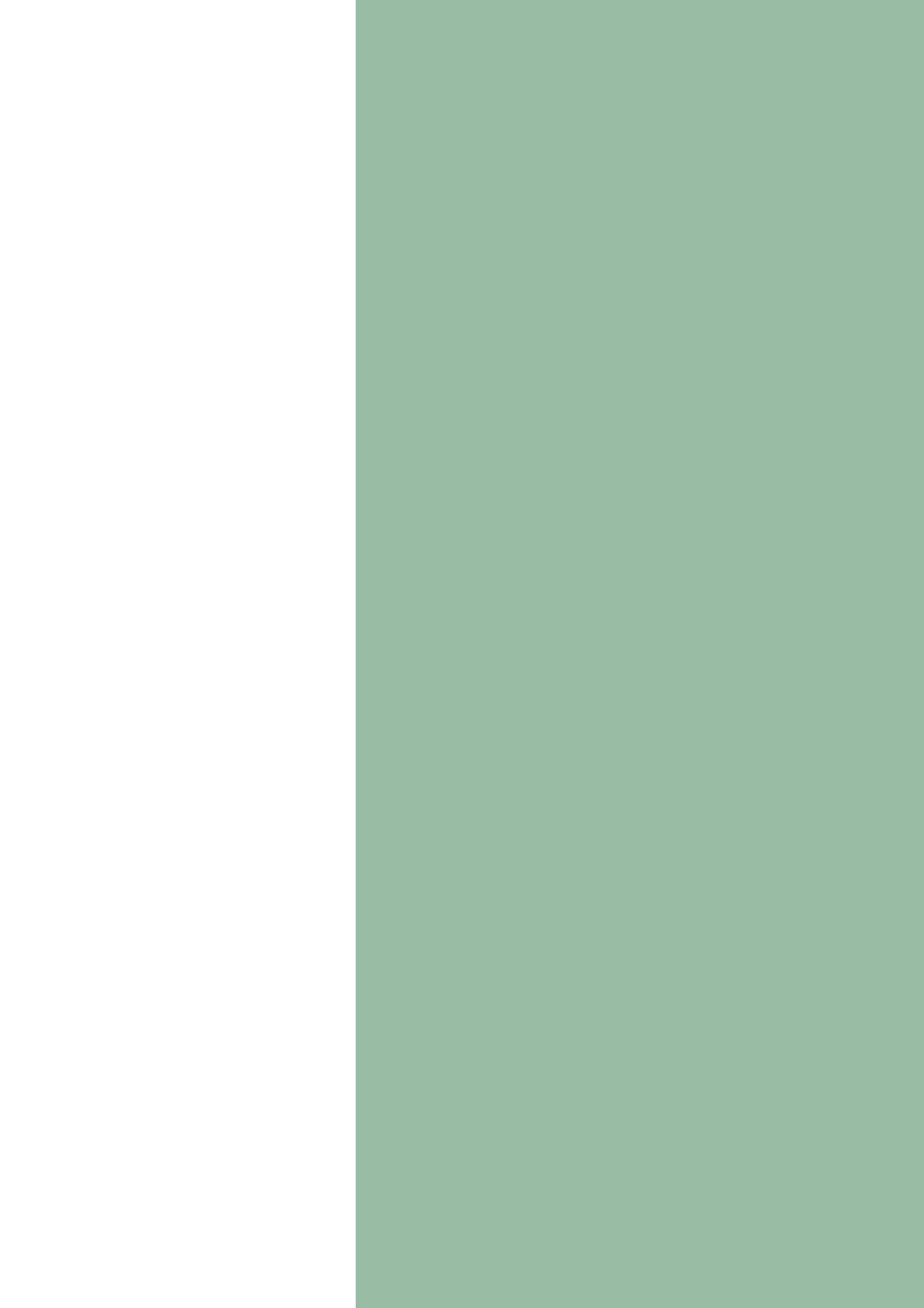



# Making Sense of the Material

## Multisensory Reader Involvement in Contemporary Multimodal Novels

Natalia Igl

### Abstract

The material dimension of literature—with regard to its textuality as well as its manifestation in form of concrete medial artefacts—has always provided the potential to make use of different semiotic resources to engage the reader. While printed media in general have been increasingly challenged within our digital age, the interest in the specific affordances of print materiality and mediality has nonetheless been rekindled within current approaches in media and literary studies. Correspondingly, recent studies on how a narrative text may engage its readers take into account literature's specific material and medial constitution. This increased interest is not least connected to the rise in so-called multimodal novels since the turn of the millennium—that is, works that integrate images and visual forms into the narration and frequently challenge the layout conventions of the printed page altogether. Following Jessica Pressman's reflections on the "aesthetic of bookishness," the genre can be seen as an illustrative case of the printed book's revitalization in the digital age by making radical use of its media-specific affordances. Drawing on current research on multimodality in literature and the materiality of reading, the article discusses how contemporary multimodal novels make use of multisemiotic strategies and foregrounded (media-)materiality to engage readers in multisensory experiences of "being present" with the book, not just the story. At this, it also stresses the importance to understand reading as a process that involves both the mind and the body. Based on a case in point analysis of J.J. Abrams & Dough Dorst's *S.* (2013), the article thus aims to demonstrate how multimodal novels functionalize their narrative composition and foregrounded print materiality to engage the "embodied reader" in a process of making sense of the text as both a story and a material artefact.

## Introduction

Studies dealing with the literary genre of the so-called multimodal novel often start with clearing up a terminological conundrum. Gibbons (2012), for instance, pointedly summarizes the basic premise of multimodality research:

Multimodality, in its most fundamental sense, is the coexistence of more than one semiotic mode within a given context. More generally, multimodality is an everyday reality. It is the experience of living; we experience everyday life in multimodal terms through sight, sound, movement. Even the simplest conversation entails language, intonation, gesture, and so forth. Indeed, many of its theorists have acknowledged that, strictly speaking, there is no such thing as a monomodal text... (Gibbons 2012, 8)

Seen from this angle, the term “multimodal novel” appears to be tautological. However, while researchers interested in specific multimodal strategies in literature do not deny the notion that all communication and correspondingly every medium is *per se* multimodal (Kress and van Leeuwen’s 2001; Baldry and Thibault 2006), they make a good case for the term’s applicability. So-called multimodal novels such as Mark Z. Danielewski’s *House of Leaves* (2000), Steve Tomasula’s *VAS: An Opera in Flatland* (2002), Jonathan Safran Foer’s *Extremely Loud and Incredibly Close* (2005), or J.J. Abrams and Dough Dorst’s *S. [Ship of Theseus]* (2013) do make use of illustrations and visual (design) elements, for example, just as many other literary genres have done throughout the history of literature and print. In the case of the multimodal novel as a particular narrative genre, however, such visual elements are not to be understood as mere illustrations but as integral parts of the otherwise strongly text-based narrative discourse and evoked storyworld, as Hallet (2009, 133) argues. With Nørgaard (2010, 115), we can thus define multimodal novels as “literary texts that make use of a variety of semiotic modes such as typography, graphics, color [sic], layout, and visual images for their meaning-making.” A crucial phenomenon connected to the multimodal strategies of such novels, moreover, is their tendency to foreground the material nature of the book as printed artefact—their “bookishness”, how Pressman (2009) puts it in a nutshell.

Within literary research, this new interest *inter alia* finds its resonance in the already mentioned notion of bookishness (Pressman 2009, 2018; Brillenburg Wurth 2011; Hayles 2013; Plate 2015; Brillenburg Wurth, Discroll, and Pressman 2018). The term as coined by Pressman (2009) refers to a re-negotiation and revitalization of the narrative and aesthetic affordances of literary texts materialized in the physically tangible form(at) of the printed book: “Works that adopt an aesthetic of bookishness respond to their contemporary, digital moment by showing how literature retains a central role in our emergent technoculture as a space for aesthetic expression and cultural critique” (Pressman 2009, 480).

Drawing on Pressman's framework, Hayles (2013) affirmatively calls for an approach to such bookish literary works that crucially factors in their performative and multisensory potentials of engaging readers as more than co-creators of textual/narrative meaning. As Hayles (2013, 231) puts it: "Texts that employ their bodies to create narrative complexity must be read not for their words alone but for the physical involvements readers undertake to access their materialities." This claim has been taken to heart, as the impressive and still increasing body of research on the phenomenon of foregrounded book-materiality in our contemporary digital ecology shows.

Back to the multimodal novel as a specific case: While it is constitutive for the genre to integrate non-verbal semiotic resources into the narration, this integration comes with different functions and effects in the concrete and diverse field of (printed) multimodal literature (Gibbons 2010, 2012a, 2012b; Hallet 2014; Nørgaard 2019; Igl 2021). As, for instance, Hallet (2014) emphasizes, these functions and effects go beyond the narrow scope of narrative meaning-making. Undoubtedly, multimodal novels utilize different semiotic modes and resources to constitute their respective storyworlds and to enable and manifest their character's epistemological metareflections on these worlds (Hallet 2014, 154–55). They also, however, crucially involve their readers in more than their typical share of making sense of the narrative:

In the narrative discourse, the verbal and the visual modes are employed each according to their specific affordance; but they are also directly interrelated and complemented by the reader's haptic activities of traditional page turning (verbal narration) and page flipping (visual narration) so that the multimodality of the novel even comprises the physical mode and the motor senses that are involved in using the book... (Hallet 2014, 155)

The physical side of interacting with the novel in its printed and codex form is of course always present—and thus always plays a certain role in how we deal and engage with a literary work (Nørgaard 2019, 274). In the case of multimodal novels, however, the performative role of their readers is strongly foregrounded, since they have to actively "explore the book page and interrelate its different semiotic elements" (Hallet 2014, 155). Thus, by means of their complex semiotic strategies of narrative meaning-making and performative reader engagement, multimodal novels also showcase the material and multisensory dimension of reading in general (Igl 2022).



## Reading as Embodied Process and Experience

Theoretically, it is part of the basic knowledge of literary studies that reading is not a purely mental process, but one in which the body of the reader also plays a role—and a crucial one at that, as Bachmann and Heimgartner (2017, 8) point out: “Our body is, apart from all the other media involved, the foremost medium through which literature and other arts work.” This view corresponds to an understanding of reading as multisensory practice and *physical* as well as mental activity, like Rautenberg (2015) outlines from a book historical perspective:

The book is conceived and handled by the book user and reader as a three-dimensional object. The first access happens with all senses, with which book block, binding and the used materials are perceived. Visual perception and haptics are the most important sensory perceptions when dealing with the codex book. (Rautenberg 2015, 290; my translation)<sup>1</sup>

While it is a fundamental premise within the field of book history to acknowledge the book’s physical-material dimension in relation to both the medial object and the reading subject alike, literary studies’ interest in materiality still tends to focus on the “text” rather than the medium as a complex semiotic artefact (Bachmann and Heimgartner 2017, 8). The comprehensive changes in the field of textual media and their corresponding forms of reading within our so-called digital age, however, have (once again)<sup>2</sup> sharpened the awareness of the fact that literature is always present in the form of complex semiotic artefacts that confront their readers with more than just text(s) materialized in a medium. Against the backdrop of the digital age, the mediality and materiality of the printed book in its codex-form is contrasted by the seeming immateriality of digital literature (Krzywkowski 2017). It has been precisely this observation of an apparent decrease of materiality in the process of literature’s shift from print to screens (Schilhab, Balling, and Kuzmičová 2018) that helped spark new interest in the affordances of literature’s medial and material aspects.

In this context, more recent research on literacy and reading acquisition has also pointed out that our everyday notion of reading may still be lagging behind our current state of knowledge, trapped in our Cartesian heritage with its basic premise of the mind-body divide. Mangen and Schilhab (2012), for instance, stress the importance to understand reading as a process that involves both the mind and the body and that reading, just like writing, is based on a complex interplay of perceptual and sensorimotor processes:

We do not only read with our eyes (not even in the most rigorous experimental setting). Neither do we write, text or tweet exclusively with our fingers and hands. All acts of human communication, creative expression, meaning construction, and learning convey the fact that, as human beings of a biological nature, our actions and interactions are inevitably and intrinsically multisensory, drawing on a range of interconnected sensory modalities defined by the total configuration of the human sensorium. (Mangen and Schilhab 2012, 286)

This understanding of reading as a multisensory process ties in with current approaches in cognitive sciences and psychology and their fundamental abandonment of the Cartesian dualistic mind-body models. From this perspective, reading is seen as an “embodied process and experience” (Kukkonen 2014, 378) with regard to two distinct dimensions of embodiment, as Schilhab, Balling, and Kuzmičová (2018) summarize: “the ‘spatio-temporal’ that relates to what the body does during the act of reading and the ‘imaginary’, that relates to the role of the body in the imagined scenarios we create from what we read.”

Kuzmičová (2012, 23) shows how such an updated notion of reading can be made fruitful for literary analysis in her approach to an “embodied theory of presence (i.e., the reader’s sense of having entered a tangible environment) in the reading of literary narrative.” Drawing on both narratological and phenomenological frameworks as well as empirically substantiated models from cognitive sciences, Kuzmičová sheds light on how textual strategies interact with a reader’s cognitive dispositions – and their fundamental ties to the multisensory, embodied reality of existing in the world—to the effect of evoking an experience of “being present”. As Kuzmičová argues, this experience is not simply evoked by means of a particularly detailed design of a storyworld that may stimulate a reader’s imagination. Rather, it is based on the interplay of linguistic cues of bodily movement and the empirically proven “motor resonance” (Gallese 2000, 2017, 2019) that these evoke in the reader:

Motor resonance stands for the referential ‘covert movement’ that has been unequivocally demonstrated, both in behavioral and neuroimaging experimental setups, to occur when literal (i.e., non-metaphorical, non-idiomatic) bodily movement sentences are processed... When people listen to or read sentences referring to bodily movement, the motor and pre-motor areas of their cortices become somatotopically activated—the hand area of the motor strip responding to hand-related action words, the feet area to feet-related action words etc. (Kuzmičová 2012, 29)

All in all, so-called second-generation or “4E” approaches within the cognitive study of literature shed new light on the ways in which readers respond to the words on the page through their actual and “virtual” bodies (Caracciolo 2011) by factoring in “the enactive, embedded, embodied, and extended qualities of the mind” (Kukkonen and Caracciolo 2014, 261; Kukkonen 2020).

From the perspective of studies investigating the phenomena of immersion in literature, of feeling “absorbed” by a narrative or being “transported” into a storyworld (Green and Carpenter 2011; Kuijpers et al. 2014), however, the “embodied reader” appears to be one whose own bodily sensations during the “here and now” of the reading process are backgrounded instead of highlighted. As Kukkonen (2020, 10–1) points out, it seems to be precisely this backgrounding of our actual, physical bodies and our immediate surroundings that enables literature to work its magic and evoke an embodied resonance through the medium of language. The notion of the embodied reader accordingly refers to “a model of the act of reading which takes into account readers’ embodied responses,” as Kukkonen (2014, 367) pointedly explains; embodied responses to textual cues, that is— not first and foremost to the textual medium as a material artefact. When it comes to multimodal novels, literature’s potential to involve the embodied reader through motor resonance and to facilitate a feeling of “being present” in the storyworld is both challenged and affirmed, as the following case in point example aims to show.

### Being Present in the Story—Being Present with the Book

In J.J. Abrams and Doug Dorst’s radically multimodal and multimedia novel *S. [Ship of Theseus]* (2013)—which functions as a particularly illustrative example for the combination of multisemiotic strategies and foregrounded (media-) materiality—the conception of the reading process as an active, multisensory interaction with the book as object is taken to extremes. Beyond confronting its readers with an ontologically complex framed narration,<sup>3</sup> the novel challenges them to handle its extended materiality and multimediality: The printed, codex-format artefact that is the novel—safely enclosed in a traditional slipcase—contains a great number of materialized elements from the storyworld such as postcards, letters, newspaper clippings, and so on, loosely inserted into the pages of the book (Fig. 1). All in all, the novel is a radically bookish object with regard to its material design, and a metafictional “book in book” story with regard to its narrative composition. It presents itself to the reader as a fictive library copy of the fictive novel *Ship of Theseus*, written by the fictive author V.M. Straka. The book’s story unfolds both in the main text (and multimedia extensions) and the colour (-coded, handwritten notes within the novel’s margins, where the fictional characters Eric and Jen enter into a dialogue about the very book they are reading and whose mystery they try to solve (Fig. 2).



Figure 1. Extended materiality in Abrams and Dorst's *S. [Ship of Theseus]*. London: Mulholland Books, 2013. Photographed by Natalia Igl. Used under the fair use principle.

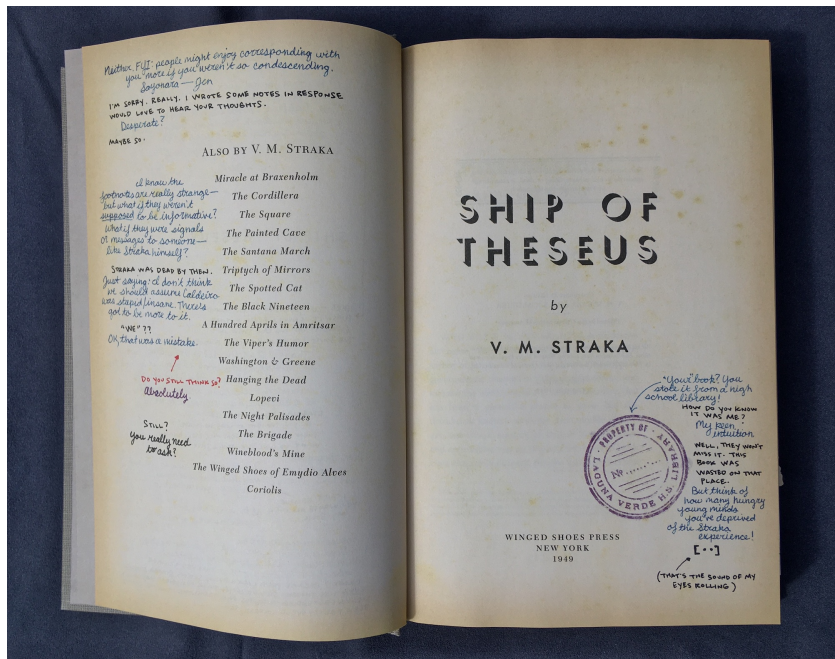

Figure 2. Handwritten notes in the margins in Abrams and Dorst's *S. [Ship of Theseus]*. London: Mulholland Books, 2013. Photographed by Natalia Igl. Used under the fair use principle.



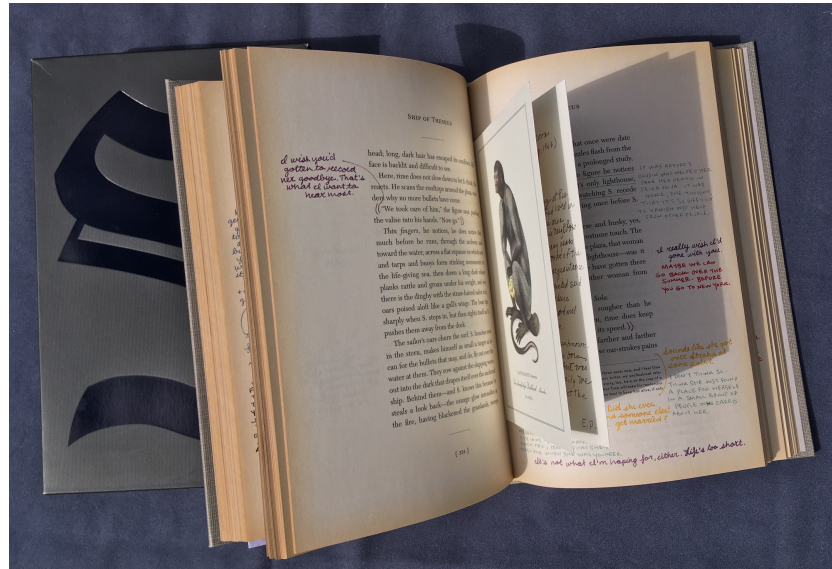

Figure 3. Combined strategies: multisemiotic page design and multimedia extensions in Abrams and Dorst's *S. [Ship of Theseus]*. London: Mulholland Books, 2013. Photographed by Natalia Igl. Used under the fair use principle.

It is very common within multimodal novels that the margins and blank space of a page or spread are utilized for metanarrative commentary and metafictional disruptions (Igl 2021). This utilization of the “marginal” can be seen as part of the multimodal novel’s characteristic play on oscillating the focus between different narrative layers and keeping the relationship between the page’s (semiotic) foreground and background (Frelik 2014) in constant motion. In accordance with this dynamic, readers of such a complex novel have to constantly negotiate the different semiotic modes and elements that constitute the narrative to co-create the text’s meaning. In the case of *S. [Ship of Theseus]*, the phenomenon of this continuous negotiation and re-adjustment of the reader’s attention proves to be a key factor in how the novel functionalizes its multimodality. While the handwritten annotations that the readers are confronted with from the moment they start engaging with the story crucially reinforce the narrative’s metafictional premise and “book in book” scenario, they also are more than just a clever device to create a framed narration and ontologically complex storyworld. Instead, they function as a means to continually evoke the readers’ sensorimotor resonance and involvement, as Ghosal (2019) argues:

To understand readers' responses to *S.*'s layout, we need to pay attention to the neuropsychological processes involved in the perception of handwriting as it is presented in the book. For the actual readers, the handwritten notes are a source of continuous visual feedback when readers are trying to fixate on the printed narrative and vice versa... *S.* is designed to stipulate numerous saccades and continually redirect the reader's attention. The visual feedback and readers' rapid, nonlinear eye movements are necessary elements constituting the experience of *S.* In other words, the handwritten notes in Abrams and Dorst's novel are designed to produce kinesthetic effects. (Ghosal 2019, 206–07)

Dealing with the continuous co-presence of the main text and the handwritten notes in the margins—which represent an extremely salient visual stimulus—requires the reader to constantly redirect their attention. With Ghosal (2019), the process of reading thus creates a physical sensation of movement on the part of the reader. Against this backdrop, the novel's multimodal page design and additional "multimedia extensions"—the enclosed postcards, newspaper clippings, etc. (Fig. 3)—can be understood as a narrative strategy that utilizes the specific affordances of the printed book as material artefact to enable an "inverted" form of immersive reading and experience of presence:

Spatial immersion, as Ryan observes, comprises a feeling of 'being there' with the characters in the storyworld, whereas handwriting brings Eric and Jen's world 'here,' making it seem to be at hand for the readers in the actual world, contributing to what Gumbrecht calls the 'presence effect' (2004, 17) of the physical book. (Ghosal 2019, 209).<sup>4</sup>

This "presence effect" of the physical book has to be considered against the backdrop of what we consider to be the default scenario in literary (novel) reading, i.e. an immersive experience in which the physical and material properties of the medium recede into the background, as Mangen (2008, 406) points out: "This is the kind of immersion we experience when reading a page-turner novel. In this kind of immersion, the physical and technical features of the material support—the book—are ideally transparent in order to facilitate, and not disturb, phenomenological immersion." In contrast, however, Clowes (2019) notes that literary texts that come to us in the form of bookish printed artefacts do not necessarily unfold their affordances most ideally when their media materiality is

faded to the background: “Books are not simply transparent objects to conduct us into an imaginative readerly world. This is only one sort of concentrated or in-depth reading which we perform with the book” (Clowes 2019, 713). As Clowes explains, the physical-material “resistance” of the book in its codex form enables a variety of reading modalities that go hand in hand with different modes of interaction (see also Rautenberg 2015 as cited above):

These include, but are not limited to, underlining and thus the easy relocation of text, marginal note-taking, and, the ability to flip through pages and thus take in at a few glances the general drift of a text. In this context, the book emerges as an artifact which is fantastically well developed for allowing a variety of forms of reading, among which are the sorts of immersed and projective reading of which reading novels is the archetype. (Clowes 2019, 713)

These different modes, as we find them in Clowes’ short outline, correspond in a remarkable way to the multimodal (narrative) design elements and cues that characterize Abrams and Dorst’s novel. Seen from this perspective, *S. [Ship of Theseus]* can be understood as a meta-novel in a double sense: On the one hand, it makes use of traditional forms of metafictional narration, which are further radicalized by the multimodal design and multimedia extensions of the novel. On the other hand, the novel appears as a metareflection on the printed book’s affordances by materializing its fictive readers’ (inter)actions in the form of handwritten notes on its pages (and many other and traces of the bookish object’s usage). These notes form also the decisive link between the novel’s metafictional design and its specific potential for an immersive reading based on sensorimotor resonance:

The readers of *S.* are neuropsychologically “moved” through their perceptions of handwriting, which mirrors the movements of the characters—*S.* wandering through the storyworld of *Ship of Theseus* and Eric and Jen wandering in its margins literally and figuratively. Handwriting is a stimulus transforming the actual reader’s embodied experience of the text. (Ghosal 2019, 208)

In this sense, multimodal novels can be understood as a narrative genre that negotiates the contrasting relationship of different reading modalities (Clowes 2019) and different forms of “being present”, as the case in point example aimed to illustrate. By means of their combined multisemiotic and (media-)material strategies they prove that a bookish narrative can do both: allow readers to experience feelings of being present with a story(world)—and what it means to be present *with a book*.

## Conclusion

When it comes to book-materiality in our contemporary digital age, multimodal novels can be interpreted both as sign of printed books' decline or defiance against their descend into medial insignificance (Pressman 2009, 477; Plate 2015, 96). It is true: In the twenty-first century, it is no longer the undisputed standard case that a novel is available to its readership as a physical, tangible object, a "bookish body" of paper and print. However, it is exactly this competitive scenario of the old print ecology being challenged by the new digital ecology (Clowes 2019; Van der Weel 2011; Baron 2015) that a new and acute perspective on the potentials and peculiarities of print mediality: "The deepening complexities of the media landscape have made mediality, in all its forms, a central concern of the twenty-first century. With that changed cultural emphasis comes a reawakening of interest in the complexities of earlier media forms as well" (Hayles and Pressman 2013, ix).

One important insight in the wake of this renewed interest and media theoretical metareflection is the (reaffirmed) realization that different media and their particular affordances must be considered based on their different materialities. This implies that all media have a material dimension. Accordingly, as for instance Hayler (2016) rightfully points out, even texts "born" to be read on screens do not forfeit the fundamental material and spatial dimension of their textuality, their characters and visual elements, their format and layout. Just as with books, reading an electronic text is not merely a visual process and experience, but also a haptic one. However, the relationship between material, medium, and text is genuinely different here: The printed text is constituted by means of its main materials (paper and ink) and its medial form and format (for instance, the book in its codex form), thus presenting itself in its medial materiality as an object that can be experienced and handled in an embodied, multisensory way. In the case of the novel as printed book, the text and the physical artefact appear even as one and the same—a conflation pointing towards the book's complex semiotic potential (Schmitz-Emans 2017). The different electronic media and their screens, which are used to read and navigate digital texts, do not constitute the artefact book itself, but provide an *interface* for its reception.

In their bookish play on print materiality, multimodal novels, as we have seen, foreground the narrative text(ure)'s multisensory nature and the performative dimension of reading as an embodied process and experience. At that, they equally functionalize the interplay of the various customary elements that constitute the printed page and tend to disrupt the design conventions that usually keep the text in its familiar shape and form (Gibbons 2012b, 420). In this sense, they can be seen as a test case for probing both the affordances of the book as printed artefact and the literary novel as a medium of embodied reader involvement.



What is more, we can look at the specific literary genre of the multimodal novel as a general reminder about the embodied nature of reading in itself. As Gibbons (2012b, 421) phrases: “we might want to think of reading multimodal novels in active terms: not just as using, but also as engaging and performing.” I would like to second that, but also extend the statement: We should think of reading in active, performative and embodied terms. Also, we should think of the reader’s active role in meaning-making as more than in textual and narrative terms. Readers make sense of a story—but by engaging with a text, they also have to make sense of its (media-)materiality.

## Acknowledgement

The research for this publication has received funding from the European Union’s Horizon 2020 research and innovation programme under the Marie Skłodowska-Curie grant agreement No 794549. The work benefitted especially from the interdisciplinary discussions and constructive feedback within the research group “Literature, Cognition and Emotions” at the University of Oslo.

## Author Biography

Natalia Igl is an associate professor in German Literature and Cultural Studies at Østfold University College, Norway, and an associate researcher at University of Oslo’s interdisciplinary hub “Literature, Cognition and Emotions.” In her latest project as Marie Skłodowska-Curie postdoctoral fellow (2018–2021) in Comparative Literature at the University of Oslo, she studied the radical forms of reader engagement in contemporary multimodal novels. Previously, she worked as an assistant professor in Modern German Literature (University of Bayreuth) and German Linguistics (Ludwig Maximilian University of Munich). Her most recent projects and publications deal with complex perspectival strategies in narrative, the “aesthetics of observation” in (German) modernism, the interplay of literature’s materiality and the embodied reader, and the role of historical illustrated magazines in the process of “training” the reader as spectator. For complete works published and more information, see the author’s profile on academia.edu. Email: natalia.igl@hiof.no. ORCID: 0000-0001-6271-6897

## Notes

1. "Das Buch wird vom Buchnutzer und Leser im Gebrauch als dreidimensionales Objekt begriffen und benutzt. Der erste Zugang geschieht mit allen Sinnen, mit denen Buchblock, Einband und die verwendeten Materialien wahrgenommen werden. Visuelle Wahrnehmung und Haptik sind die wichtigsten Sinneswahrnehmungen im Umgang mit dem Codexbuch" (Rautenberg 2015, 290).
2. The recollection of the medial-material constitution of literature is a recurring moment within both literary history and studies, cf. for example Brillenburg Wurth (2018) on the "loops and returns" of comparative literary studies' turn to materiality.
3. See Igl 2019 on narrative framing strategies as ways to mediate and bridge the boundary between intra- and extratextual worlds.
4. Ghosal (2019, 209) refers to the following two studies: Marie-Laure Ryan. *Narrative as Virtual Reality: Immersion and Interactivity in Literature and Electronic Media* (Baltimore: Johns Hopkins University Press, 2001); Hans Ulrich Gumbrecht. *Production of Presence: What Meaning Cannot Convey* (Stanford: Stanford University Press, 2004).

## Bibliography

- Abrams, J. J., and Doug Dorst. *S. [Ship of Theseus]*. London: Mulholland Books, 2013.
- Bachmann, Christian A., and Stephanie Heimgartner. "Books, Materials, Texts: A Threefold Foreword". In *BOOK – MATERIAL – TEXT. Essays on the Materiality, Mediality and Textuality of the (e-)Book*, edited by Christian A. Bachmann and Stephanie Heimgartner, 4–10. Ruhr-University Bochum, 2017. <https://doi.org/10.13154/bmt.1.2016.4-10>.
- Baldry, Anthony, and Paul J. Thibault. *Multimodal Transcription and Text Analysis*. London, Oakville: Equinox, 2006.
- Baron, Naomi S. *Words Onscreen. The Fate of Reading in a Digital World*. Oxford. New York: Oxford University Press, 2015.
- Brillenburg Wurth, Kiene. "Old and New Medialities in Foer's *Tree of Codes*. *CLCWeb. Comparative Literature and Culture* 13 (2011). <https://doi.org/10.7771/1481-4374.1800>.
- . "The Material Turn in Comparative Literature: An Introduction." *Comparative Literature* 70 (2018): 247–63.
- Brillenburg Wurth, Kiene, Kári Discroll, and Jessica Pressman, eds. *Book Presence in a Digital Age*. New York: Bloomsbury, 2018.
- Caracciolo, Marco. "The Reader's Virtual Body: Narrative Space and its Reconstruction." *Storyworlds* 2 (2011): 117–38.
- Clowes, Robert W. "Screen Reading and the Creation of New Cognitive Ecologies." *AI & Society* 34 (2019): 705–20. <https://doi.org/10.1007/s00146-017-0785-5>.
- Danielewski, Mark Z. *House of Leaves*. New York: Pantheon Books, 2000.
- Foer, Jonathan Safran. *Extremely Loud and Incredibly Close*. Boston: Mariner Books, 2005.
- Frelik, Pawel. "Reading the Background: The Textual and the Visual in Steve Tomasula's *The Book of Portraiture*." *Sillages critiques* 17 (2014). <https://doi.org/10.4000/sillagescritiques.3582>.

- Gallese, Vittorio. "The inner sense of action: Agency and motor representations." *Journal of Consciousness Studies* 7 (2000): 23–40.
- . "Visions of the body: Embodied simulation and aesthetic experience." *Aisthesis* 1 (2017): 41–50.
- . "Embodied Simulation. Its Bearing on Aesthetic Experience and the Dialogue Between Neuroscience and the Humanities." *Gestalt Theory* 41 (2019): 113–28. <https://doi.org/10.2478/gth-2019-0013>.
- Ghosal, Thorsa. "At Hand: Handwriting as a Device for Spatial Orientation in J.J. Abrams and Doug Dorst's *S.*" *Poetics Today* 40 (2019): 189–213.
- Gibbons, Alison. "Narrative worlds and multimodal figures in *House of Leaves*: '—find your own words; I have no more.'" In *Intermediality and Storytelling*, edited by Marina Grishakova and Marie-Laure Ryan, 285–311. Berlin, New York: De Gruyter, 2010.
- . *Multimodality, Cognition, and Experimental Literature*. New York, London: Routledge, 2012a.
- . "Multimodal Literature and Experimentation." In *The Routledge Companion to Experimental Literature*, edited by Joe Bray, Alison Gibbons, and Brian McHale, 420–34. London, New York: Routledge, 2012b.
- Green, Melanie C., and Jordan M.A. Carpenter. "Transporting into narrative worlds. New directions for the scientific study of literature." *Scientific Study of Literature* 1 (2011): 113–22.
- Hallet, Wolfgang. "The Multimodal Novel: The Integration of Modes and Media in Novelistic Narration." In *Narratology in the Age of Cross-Disciplinary Narrative Research*, edited by Sandra Heinen and Roy Sommer, 129–53. Berlin, New York: De Gruyter, 2009.
- . "The Rise of the Multimodal Novel: Generic Change and its Narratological Implications." In *Storyworlds across Media. Toward a Media-Conscious Narratology*, edited by Marie-Laure Ryan and Jan-Noël Thon, 151–172. Lincoln, London: University of Nebraska Press, 2014.
- Hayler, Matt. "Matter Matters: The Effects of Materiality and the Move From Page to Screen." In *Research Methods for Reading Digital Data in the Digital Humanities*, edited by Matt Hayler and Gabriele Griffin, 14–35. Edinburgh: Edinburgh University Press, 2016.
- Hayles, N. Katherine. "Combining Close and Distant Reading: Jonathan Safran Foer's *Tree of Codes* and the Aesthetic of Bookishness." *PMLA* 128 (2013): 226–31.
- Hayles, N. Katherine, and Jessica Pressman. "Introduction. Making, Critique: A Media Framework." In *Comparative Textual Media. Transforming the Humanities in the Postprint Era*, edited by N. Katherine Hayles and Jessica Pressman, vii–xxxiii. Minnesota: University of Minnesota Press, 2013.
- Igl, Natalia. "Framing the narrative: The 'fictive publisher' as a bridge builder between intra- and extratextual world." In *Experiencing Fictional Worlds*, edited by Benedict Neurohr and Lizzie Stewart-Shaw, 97–117. Amsterdam, Philadelphia: John Benjamins, 2019.
- . "Multisensorische Lektüren: Zur Rezeption und Meta-Ästhetik multimodaler Gegenwartsromane." In *META-Fiktionen. Der experimentelle Roman seit den 1960er Jahren*, edited by Wilhelm Haefs, Stefan Brückl, and Max Wimmer, 331–63. München: text+kritik, 2021.
- . "The Materiality and Multimodality of Literature." In *Podcast: "Literature, Cognition and Emotions."* University of Oslo, June 24, 2022. <https://www.hf.uio.no/english/research/strategic-research-areas/lce/news-and-events/news/2022/season-2-ep-2-natalia-igl.html>

- Kuijpers, Moniek M., Frank Hakemulder, Ed S. Tan, and Miruna M. Doicaru. "Exploring absorbing reading experiences: Developing and validating a self-report scale to measure story world absorption." *Scientific Study of Literature* 4 (2014): 89–122.
- Kukkonen, Karin. "Presence and Prediction: The Embodied Reader's Cascades of Cognition." *Style* 48 (2014): 367–84.
- . *Probability Designs: Literature and Predictive Processing*. Oxford: Oxford University Press, 2020.
- Kukkonen, Karin, and Marco Caracciolo. "Introduction: What is the "Second Generation?" *Style* 48 (2014): 261–74.
- Kuzmičová, Anežka. "Presence in the reading of literary narrative: A case for motor enactment." *Semiotica* 189 (2012): 23–48.
- Kress, Gunther, and Theo van Leeuwen. *Multimodal Discourse: The Modes and Media of Contemporary Communication*. London: Arnold, 2001.
- Krzywkowski, Isabelle. "Immateriality of the Work vs. Materiality of the Body? Digital Literature." In *BOOK – MATERIAL – TEXT. Essays on the Materiality, Mediality and Textuality of the (e-) Book*, edited by Christian A. Bachmann and Stephanie Heimgartner, 28–40. Ruhr-University Bochum, 2017. <https://doi.org/10.13154/bmt.1.2016.28-40>
- Mangen, Anne. "Hypertext fiction reading: Haptics and immersion." *Journal of Research in Reading* 31 (2008): 404–19.
- Mangen, Anne, and Theresa Schilhab. "An embodied view of reading: Theoretical considerations, empirical findings, and educational implications." In *Skriv! Les! 1: Artikler fra den første nordiske konferansen om skrivning, lesing og literacy*, edited by Synnøve Matre and Atle Skaftun, 285–300. Trondheim: Akademika, 2012.
- Nørgaard, Nina. "Multimodality and the Literary Text. Making Sense of Safran Foer's *Extremely Loud and Incredibly Close*." In *New Perspectives on Narrative and Multimodality*, edited by Ruth Page, 115–126. New York, London: Routledge, 2010.
- . *Multimodal Stylistics of the Novel: More Than Words*. New York, London: Routledge, 2019.
- Plate, Liedeke. "How to Do Things with Literature in the Digital Age: Anne Carson's *Nox*, Multimodality, and the Ethics of Bookishness." *Contemporary Women's Writing* 9 (2015): 93–111.
- Pressman, Jessica. "The Aesthetic of Bookishness in Twenty-First-Century Literature." *Michigan Quarterly Review* 48 (2009): 465–82.
- Rautenberg, Ursula. "Das Buch in der Codexform und einblättrige Lesemedien." In *Lesen. Ein interdisziplinäres Handbuch*, edited by Ursula Rautenberg and Ute Schneider, 279–336. Berlin, Boston: De Gruyter, 2015.
- Schilhab, Theresa, Gitte Balling, and Anežka Kuzmičová. "Decreasing materiality from print to screen reading." *First Monday* 23 (10) (2018). <http://dx.doi.org/10.5210/fm.v23i10.9435>.
- Schmitz-Emans, Monika. "Books as Material, Virtual, and Metaphorical Entities." In *BOOK – MATERIAL – TEXT. Essays on the Materiality, Mediality and Textuality of the (e-)Book*, edited by Christian A. Bachmann and Stephanie Heimgartner, 11–27. Ruhr-University Bochum, 2017. <https://doi.org/10.13154/bmt.1.2016.11-27>.
- Tomasula, Steve. *VAS: An Opera in Flatland*. Chicago: University of Chicago Press, 2002.
- Van der Weel, Adriaan. *Changing our Textual Minds. Towards a Digital Order of Knowledge*. Manchester, New York: Manchester University Press, 2011.



# Art is All

## Proust's Life Lessons Through Perception and Art

J. Philippe Thompson

### Abstract

For Proust, why does error precede truth? In his *In Search of Lost Time*, Proust seems to paint his narrator's errors in his search for truth. To understand *In Search of Lost Time*, one must unlock Proust's formula or secret code. Scholars have explored Proust's "optical illusions" with an emphasis on optics or as part of contemporary art movements. Our discussion examines what Proust called the "medley of impressions which we call vision," or, in artistic terms, what impressionist painters sought to capture in an impression of a moment. By examining the narrator's "aesthetic of a re-rooting in perspective" in *In Search of Lost Time* through Impressionism, I wish to clarify how Proust viewed art, in terms of its illusionary purpose within the novel, as well as the functionality of the novel's featured paintings both symbolically and metaphorically, through a Structuralist examination of codes. Decoding a text, however, may not be as simple as just following established codes of interpretation: some authors attempt a direct subversion of codes, which Roland Barthes, in *The Death of the Author*, notes in the case of Marcel Proust's *In Search of Lost Time* as Proust was visibly concerned with the task of inexorably blurring, by an extreme subtilization, the relationships in the novel. In other words, is the placement of works of art and the presence of these scenes intended to educate readers, in part, by showing how works of art are not to be read? The answer to this question is the subject of this essay, as I will attempt to identify Proust's conscious intent in providing life lessons through art by his showing patterns of relations to art and story structure, thus revealing meaning in one of the most important and influential novels of the twentieth century: *In Search of Lost Time*.

## Introduction

*From one art to another, witness all the times when the actual vehicle of a work of art baffles the critics, whether it be a foreign language or a technique he does not know about?) As it is beauty of statement that alone individualizes the idea and marks at what depth of the creative mind the idea was worked out, if this vehicle obscures the work of art instead of throwing light on it, we are reduced to guesswork, and often guess wrong. –Marcel Proust, “The Creed of Art”<sup>1</sup>*

*Our judgment does not reckon in their exact and proper order things which have come to pass at different periods of time; for many things which happened many years ago will seem nearly related to the present, and many things that are recent will seem ancient, extending back to the far-off period of our youth. And so it is with the eye, with regard to distant things, which when illuminated by the sun seem near to the eye, while many things which are near seem far off. —Leonardo da Vinci<sup>2</sup>*

In considering perceptions in Proust, why does error precede truth? In his *In Search of Lost Time*, Proust seems to paint his narrator’s errors in his search for truth. As Vincent Descombes explains, truth results from the search, not its point of departure, as one must rectify the errors with which one began in order to progress toward truth.<sup>3</sup> In *The Captive*, Proust’s narrator instructs both readers, and Albertine, that “instead of presenting things in their logical sequence, that is to say beginning with the cause, shows us first of all the effect, the illusion that strikes us,” which is “as deceptive as those effects in Elstir’s pictures where the sea appears to be in the sky.”<sup>4</sup> To understand *In Search of Lost Time*, one must unlock Proust’s formula or secret code like, as Descombes states, “an open sesame allowing access to the work.”<sup>5</sup> Via *The Guermantes Way*, Proust explains that pictures can recreate “optical illusions” test will test us in “identifying objects.”<sup>6</sup> Literary critics and scholars, like Walter Benjamin, Evelyne Ender, Gérard Genette, Françoise Leriche, and Roger Shattuck have explored Proust’s “optical illusions” with an emphasis on optics, while others, have considered these illusions as part of contemporary art movements: Nathalie Dyer (Primitivism), Jan Hokenson (Japonisme), Eric Karpeles (Postmodernism), and Martha Wiseman (Theater of Dreams). This paper will examine what Proust called the “medley of impressions which we call vision,” or, in artistic terms, what impressionist painters sought to capture in an immediate impression of a moment, which will extend beyond Mary Rawlinson’s analysis in “Proust’s Impressionism.” By examining the narrator’s “aesthetic of a re-rooting in perspective” in *In Search of Lost Time* through Impressionism, what Proust called the “appropriate style in which to

present our apprenticeship in life," I wish to clarify how Proust viewed art, in terms of its illusionary purpose within the novel as the misperception of art by the narrator allows us to chart the growth of perception in the narrator in more general terms. In other words, is the placement of works of art and the presence of these scenes intended to educate readers, in part, by showing how works of art are not to be read? The answer to this question is the subject of this essay, as I will attempt to identify Proust's conscious intent in providing life lessons through art by his showing patterns of relations to art and story structure, thus revealing meaning in one of the most important and influential novels of the twentieth century: *In Search of Lost Time*.

In *Toward an Aesthetic of Reception*, Hans Robert Jauss explored construct of the reader at the expense of both the author and text. Jauss's focus on the reader helps to frame our discussion as the way we consider past receptions of texts to current ones is a means of discerning the understanding of readers.<sup>7</sup> Walter Benjamin, in *Theses on the Philosophy of History*, explains that in order to "articulate the past historically does not mean to recognize it the way it was," but to "seize hold of a memory as it flashes up at a moment of danger" where the "image of the past which unexpectedly appears to man...must be made to wrest tradition away from a conformism that is about to overpower it."<sup>8</sup> In writing about Proust, Benjamin explains that "most memories that we search for come to us as visual images. Even the free-floating forms of the *memoire involunataire* are...isolated, though enigmatically present, visual images."<sup>9</sup>

These visual images, or as Eric Karpeles notes, "allusions to paintings and painters," are what Proust presents the reader "in varying guises" that "serve multiple purposes" in *In Search of Lost Time*.<sup>10</sup> The novel has "many layers of reference whose borders are continually transgressed, where art and reality, painting and life, subtly transform and meld" and Proust's "sustained integration of image and written text, characters and pictures seem to melt into each other."<sup>11</sup> In *Swann's Way* we observe Charles Swann, in his second visit to Odette de Cr cy, and how the words "Florentine painting" provide him a great service in viewing Odette, as she strikes Swann by her resemblance to Zipporah, Jethro's daughter, in a fresco in the Sistine Chapel. Swann reproaches himself for having "misunderstood the value of a creature who...appeared captivating to the great Sandro, and he felt happy that his pleasure in seeing Odette could be justified by his own aesthetic culture."<sup>12</sup> Swann's interactions with Odette, through the lens of art, change him as "he himself was no longer the same."<sup>13</sup> Swann uses the picture of the girl in the Sistine fresco optically, as a prism, to spread upon the figure of Odette the broadest spectrum of colors and possibilities as the painting's reflected glow of the orchid-loving courtesan emerges transfigured into someone good, someone biblical.<sup>14</sup> Jonathan Crary, in *Suspensions of Perception*:



*Attention, Spectacle, and Modern Culture*, examined the components of a cultural environment in which new truths and new uncertainties about perception were being contested and reconstructed, within both visual modernism and a modernizing mass visual culture, beginning in the late 1870s.<sup>15</sup> The idea of subjective vision—the notion that our perceptual and sensory experience depends less on the nature of an external stimulus than on the composition and functioning of our sensory apparatus—was one of the conditions for the historical emergence of notions of autonomous vision and of a severing or liberation of perceptual experience from a necessary relation to an exterior world.<sup>16</sup> Cray, in discussing Benjamin's historicization of perception, explains how the privileged model of the individual observer presupposed an ideal of attentive intersubjectivity, as opposed to modern forms of interiority, absorption, and psychic isolation, or to the dissolution of the communal world which he saw figured within the general cultural phenomenon of impressionism.<sup>17</sup> We will now turn to the cultural phenomenon of impressionism, around which, Proust sought to educate his readers on issues of perception and misperception.

### *A la recherché du impressionnisme* (In search of the impressionism)

Mary Rawlinson summarizes Proust's impressionism as an idea where "only the impression is a guarantor of truth, and the advancement of impressionism itself will be governed by this rule," and that Proust's impressionism advances "not by way of theories, rather, via certain impressions" as the writer expresses "only those truths that he has been forced to think by life itself, so too the reader finds those truths demonstrated only on the basis of certain actual impressions recreated by the text."<sup>18</sup> Rawlinson concludes that only through the appropriation and expression of the impressions of life and art can an individual see what underlies their expressions and impressions.<sup>19</sup> The scene at the Rivebelle restaurant in *Within a Budding Grove* to illustrate Proust's impressionist writing style where "All this dizzy activity became fixed in a quiet harmony" where the "harmony of these astral tables did not prevent the incessant revolution of the countless waiters," who "performed their gyrations in a more exalted sphere" and "their perpetual course among the round tables yielded...to the observer the law of its dizzy but ordered circulation."<sup>20</sup> As Rawlinson notes, there is a "profound kinship of Proust's style" to impressionism, which forces us to return to root of our impression.<sup>21</sup> Impressionist painting upsets our natural attitude and presents us with both the truly ambiguous character of sensation and the intellectual process of distinction.<sup>22</sup> In contemplating Proust's impressionist style, we will consider Gérard Genette's investigation into Proust's narrative techniques.

In *Narrative Discourse*, Genette references Elstir's seascapes at Balbec where we see how "jammed they are with terms designating not what the painting of Elstir is," but "the 'optical illusions' that it 'recreates,' and the false impressions it

arouses and dissipates in turn: *seem, appear, give the impression, as if, you felt, you would have said, you thought, you understood, you saw reappear, they went racing over sunlit fields, etc.*"<sup>23</sup> Aesthetic activity centers on the sleight-of-hand "metaphors" of the impressionist painter. The same labor of perception, the same struggle or play with appearances, occurs again in the presence of the slightest object or landscape.<sup>24</sup> Optical illusions? Proust himself first references this term in his second volume, *Within A Budding Grove*, where the effort made by Elstir to "reproduce things not as he knew them to be but according to the optical illusions of which our first sight of them is composed, had led him precisely to bring out certain of these laws of perspective."<sup>25</sup> Roger Shattuck acknowledges that Proust drew on "an incredibly rich repertory of metaphors," but it is through the "science and art of optics" that Proust "beholds and depicts the world" and that "truth," which Proust believed in, "is a miracle of vision."<sup>26</sup> Proust's systematic cataloguing of visual figures reveals a great deal in a short space as the simplest optical imagery results from the particular attention Proust pays to visual and light effects, most of them in nature, a few of them associated with art.<sup>27</sup> The further a reader ventures into *In Search of Lost Time*, optical illusions occur more frequently and in greater depth. For the narrator Marcel, social classes first appear in the novel as "clearly defined layers; and, of necessity, perception from one level to the next, or to a level several times removed, entails severe refraction and distortion," as Marcel, "looking up toward the higher circles, misjudges everyone in the beginning."<sup>28</sup>

Early in the novel in *Swann's Way*, our narrator, reflecting back on his younger self, explains that "there were two ways which one could go for a walk" in Combray: either the Méséglise-la-Vineuse way ("Swann's way") or the Guermantes way.<sup>29</sup> Our young narrator faces a fork in the road, a duality of experience that will echo out in the novel in various ways. Which path does young Marcel choose? The narrator considers both paths, and later finds they converge in the form of Mlle. de Saint-Loup. As Gilles Deleuze explains in *Proust and Signs: The Complete Text*, Proust sets the double idea of constraint and of chance as truth depends on an encounter with something that forces us to think and to seek the truth.<sup>30</sup> This question of optics brings us to our narrator's encounter with "the painter."

Marcel receives an instructive lesson in "seeing" from Elstir in *Within A Budding Grove* that proves important in his development as an observer and writer. Elstir explains "there is no man...however wise, who has not at some period of his youth said things, or lived a life, the memory of which is so unpleasant to him that he would gladly expunge it."<sup>31</sup> Elstir continues stating that "we do not receive wisdom, we must discover it for ourselves" and that he "can see that the picture of what we were at an earlier stage may not be recognizable and cannot, certainly, be pleasing to contemplate in later life. But we must not repudiate it, for it is proof that we have really lived."<sup>32</sup> In one of many "eye-opening" conversations, Elstir tells Marcel he must make his own journey through the wilderness and that there

is no easy way to work through the distortions of love and life. In *The Captive*, Marcel better understands the "twofold diversity" to life as the spectrum makes visible to us "the composition of light, so the harmony of a Wagner, the colour of an Elstir, enable us to know that essential quality of another person's sensations into which love for another person does not allow us to penetrate" ...then a "diversity inside the work itself...combining diverse individualities."<sup>33</sup>

Still, Marcel yearns for direct or straightforward answers, or truth, but he discerns in *The Fugitive* that there are "optical errors in time as there are in space" and that "we would like the truth to be revealed to us by novel signs, not by a sentence, a sentence similar to those...we have constantly repeated to ourselves."<sup>34</sup> Marcel's gradual perceiving of the dual natures, or better "revised projections," of Rachel, then Gilberte and Albertine, whom Saint Loup does not thrill over like the Trojan elders with Helen, yields the revelation that "the difference in optics extends not only to people's physical appearance but to their character, and to their individual importance."<sup>35</sup> In fact, even Marcel himself comes to realize his own duality, as Mama, in *The Captive*, tells Marcel "you do not know what you want and are two or three people at once."<sup>36</sup> Subsequently, in *The Captive* at the Bois, our narrator references "a spell of chiaroscuro."<sup>37</sup> Chiaroscuro, a technique first perfected by Leonardo da Vinci, uses strong contrasts between and light and dark in a composition. As Albertine and Marcel leave their motor-car to walk, our narrator explains the chiaroscuro's bipartite effect on them as they seemed "united," their "two persons in a single self and linked our destinies together...our shadows, now parallel, now close together and joined...the fusion of our shadows had a charm for me that was doubtless more insubstantial, but no less intimate, than...the fusion of our bodies."<sup>38</sup> As Marcel continues to reflect on Albertine, he realizes that every person is "to us like Janus, presenting to us the face that pleases us if that person leaves us, the dreary face if we know him or her to be at our perpetual disposal" and that of "every person we know we possess a double."<sup>39</sup> Marcel further elaborates on the idea of duality to Albertine in *The Captive* where he explains Mme. de Sévigné, Elstir, and Dostoyevsky first show us "the effect" or the illusion that "strikes us" as their actions are as "deceptive as those effects in Elstir's pictures where the sea appears to be in the sky. We're quite surprised to find later on that some sly-looking person is really the best of men, or vice versa."<sup>40</sup> The question of perception or misperception serves an important role in the development of Proust's narrator in his search for truth throughout *In Search for Lost Time*.

## “Don’t Dream It’s Over”

Through Shattuck’s framework, we have discussed some of the ways Proust uses optical imagery in concert with mental capacity, but it is also worth noting the function of the states of consciousness that Proust presents, of sleep, of wakefulness, and, his favorite, that transitional or hypnopompic state of consciousness upon awaking where one may incur hallucinations. In *The Captive*, Marcel proclaims that the “dream world is not the waking world” but in the world of sleep, our “perceptions are so overloaded, each of them blanketed by a superimposed counterpart which doubles its bulk and blinds it to no purpose, that we are not able even to distinguish what is happening in the bewilderment of awakening.”<sup>41</sup> Sleep and dreams function, as Martha Wiseman states, as a generating source for all the stories the *Search* encompasses.<sup>42</sup> The dream is an endless, circular bedtime story, a story a mother might read to a child to assure them that they are safe in the darkness of sleep, a story that has no end so that endings are not feared.<sup>43</sup> Proust proves that sleep and dreaming are on many levels active states.<sup>44</sup> Sleep is also essential for our survival sleep ends the day but in order to make the next day possible.<sup>45</sup> Dreams seem to suggest to the narrator his own duality in *Sodom and Gomorrah* as he craves his grandmother’s presence, but “in a sense he has helped to kill her, not just by his indifference and forgetting in the previous year, but by dreaming of her as absent, as in a kind of limbo, an antechamber to death, and then by awakening from his dreams and leaving her behind in that half-lit place.”<sup>46</sup>

In considering dreams from early on in *Swann’s Way*, the narrator takes us through a hypnopompic moment where the objects we, the readers, first encounter include both a candle and the narrator’s eyes and then expand out to a “kaleidoscope of darkness,” then to a “magic armchair” that can travel through time and space, and finally to a magic lantern, which “replaced the opacity of the walls with impalpable iridescences, supernatural multicolored apparitions, where legends were depicted as in a wavering, momentary stained-glass window.”<sup>47</sup> As Shattuck explains, “this strand of imagery, linking not so much things seen as particular circumstances or modes of vision, never slackens through three thousand pages of text.”<sup>48</sup> The errors Marcel experiences, or optical illusions, independent of its corresponding state of consciousness, provides the material from which “truth” will emerge.<sup>49</sup> We see that “truth and reality in Proust have no objective, verifiable existence” and are the aesthetic “creations of our intuitions, of our minds, fixed in a work of art.”<sup>50</sup> Thus, “by an act of creation that truth emerges from deception and illusion” and that “Marcel’s vision of truth and his sense of vocation occur as one ‘recognition’ in the novel, for they are merely different aspects of the same process of creating our world.”<sup>51</sup> We must create our truth of existence if “we can recognize its pattern and relief in time; and in the same way we truly create ourselves, our character, by a long and often delayed act of self-recognition.”<sup>52</sup> So why does Proust take seven volumes to present us, his readers, with, as Shattuck asks, an “erroneous universe from which the true dimension is missing?”<sup>53</sup> The answer is in the very question of the novel as an art form.

What do we find inside *In Search of Lost Time*? Evelyne Ender and Serafina Lawrence find the novel, as a work of art in the form of fiction, provides its own answer as a “sum total of an experience.”<sup>54</sup> The memories recounted in *In Search of Lost Time*, can “cross the mirror that shows ‘the child who for the first time spelt out the book’s title in the little bedroom’ and whose memory ‘must not be buried in oblivion.’”<sup>55</sup> At the other end of the spectrum we find a book in process that born from young Marcel’s initiation to another book. Proust reunites “the soon to become writer with the reading child, the author points at the crucial significance of what turns out to be a primal scene for the literary Bildungsroman that is the *Recherché*.”<sup>56</sup> By placing the image of “the reading child at this nodal point of the *Recherché*, the memories show the book’s crucial role in an aesthetic education which, for Proust, can only happen at the convergence between knowledge and affect.”<sup>57</sup> In *Time Regained*, Proust comments on the importance of an aesthetic education though the education of his own narrator: “this most wonderful of all days...illuminated for me...the whole purpose of my life and perhaps art itself” and the books “I read in the past... enriched now by my memory with vast illuminations.”<sup>58</sup> Parallel to Ender’s discussion, I believe we too should “probe into what is hidden inside” *In Search of Lost Time* to “enrich our understanding” of the function of art as part of Proust’s lessons on aesthetic education.<sup>59</sup>

### *L’art pour l’art*<sup>60</sup>

For Proust, art plays a formative role in training our aesthetic sensibility. The person who has lived a full, varied life frequently fails to recognize its meaning or even to appreciate its qualities until encountering it afresh in a work of art.<sup>61</sup> Narrator Marcel learns to appreciate things he may at first disdain. On one of his early visits to Elstir in Balbec, Elstir surprises the narrator by what he elects to show him and the girls: a sketch made on a race-course near Balbec. Marcel admits to Elstir that he “had not felt inclined to go to the meetings that were being held there,” but Elstir tells Marcel, “You were wrong...it is such a pretty sight, and so strange too.”<sup>62</sup> Elstir helps Marcel see the race-meetings and regattas in a new light, as Marcel realizes such activities would interest a modern artist, much like the festivities depicted in a Veronese or in the water-tournaments of Carpaccio’s *Legend of Saint Ursula*.

When Elstir and Swann discuss the show of a recently deceased artist friend of Mme. Verdurin in *Swann’s Way*, Swann makes a comment similar to Marcel’s aforementioned observation, “it didn’t seem to me to be an art that was...all that elevated.”<sup>63</sup> But the painter, instead of answering Swann in an instructive or affirming way, prefers to win the admiration of the guests by stating that, “The thing looked as though it were made with nothing at all...absolutely no way of discovering the trick, any more than in *The Night Watch* or *The Regents*, and the brushwork is even stronger than Rembrandt or Hals.”<sup>64</sup> Mme. Verdurin protests this blasphemy against *The Night Watch* as she considers it the greatest

masterpiece in the world, exclaiming, “how he amuses me when he gets carried away like that.”<sup>65</sup> Given Elstir’s past with Odette, his response here seems in keeping with the outcome of his past relationship, although narrator has yet to reveal Elstir’s Odette connection at this point.

Art seems to never be far from the narrative line in the *Search for Lost Time*, but Marcel, much like Swann, Bergotte, and Charlus, has impressions that can miss the mark.<sup>66</sup> Several characters find Elstir and his impressionism provocative, his “fragments of a world of new and strange colours” that “seemed most absurd to people in fashionable society.”<sup>67</sup> Elstir’s works, however, interest Marcel because they “re-created those optical illusions which prove to us that we should never succeed in identifying objects if we did not bring some process of reasoning to bear on them.”<sup>68</sup> The people who “detested these ‘horrors’ were astonished to find that Elstir admired Chardin, Perronneau, and many other painters...[that] ordinary men and women of society liked.”<sup>69</sup> Why was Proust drawn to impressionism? What purpose does his fictional impressionist painter Elstir serve? The answer to these questions lies in the aesthetic education of the narrator as the young Marcel learns, as Alain de Botton notes, to “challenge the orthodox understanding of what things look like” thanks to Elstir.<sup>70</sup> In discussing Davioud’s Trocadéro in *The Captive*, Marcel expresses his concept of impressionism and the novel’s impressionist exemplar to Albertine: “I don’t mind telling you things that would generally be regarded as false but which correspond to a truth that I’m searching for. You know what is meant by impressionism?”<sup>71</sup> Elstir’s impressionism occurs, for example, when he “abstracts such buildings from the global impression in which they’re included, brings them out of the light in which they are dissolved and scrutinizes their intrinsic merit like an archaeologist?”<sup>72</sup> The work of Elstir, much like that of the “real” impressionists that he resembles—Claude Monet, James Whistler, etc.—may have seemed like the product of “flinging a pot of paint” to critics, like our dear John Ruskin, who questioned the technical skill of impressionists (at least impressionists were not given a derogatory label like “les Fauves” like the painters of the Fauvist art movement that followed them). *In Search of Lost Time* features many characters who fashion themselves as art critics with supreme aesthetic taste.

As Marcel explains in *The Guermantes Way*, Mme. de Guermantes’s “taste was the opposite of my own, she...never seemed to me so stupidly Faubourg Saint-Germain as when she talked literature...she hated Elstir’s work” and comments on her portrait as being “ghastly thing” that is “not going to make his name live for posterity.”<sup>73</sup> In similar fashion, M. de Guermantes observes that “one doesn’t need to be an expert to look at that sort of thing...I don’t feel myself that he puts enough work into them. Swann had the nerve to try and make us buy a *Bundle of Asparagus*...[Elstir is] intelligent...you’re surprised, when you talk to him, that his paintings should be so vulgar.”<sup>74</sup> Later on in the same conversation, when asked by Marcel whether he had admired Vermeer’s *View of Delft*, M. de

Guermantes does not remember having seen the painting and exclaims, "if it's to be seen, I saw it."<sup>75</sup> Marcel shocks Mme. de Guermantes when he mentions that he did not have time to visit Haarlem and see the Halses, which causes her to say that if someone on top of a tram "only caught a passing glimpse of them...would open his eyes pretty wide."<sup>76</sup> Mme. de Guermantes's remark shocks Marcel as "indicating a misconception of the way in which artistic impressions are formed in our minds...to imply that our eyes...[are] simply a recording machine which takes snapshots."<sup>77</sup> A few volumes later in *The Fugitive* we find, of course, that "Elstir was now in fashion" and that Mme. de Guermantes could not forgive herself for giving away so many of Elstir's pictures to her cousin, not because they were in fashion, but "because she now appreciated them."<sup>78</sup> Marcel's interactions with the Guermantes regarding taste in art serve in furthering his aesthetic education; yet, the most memorable lesson in aesthetic education in the novel occurs when Marcel gives the young Mme. de Cambremer an aesthetic wake-up call.

### "Don't Let The Sun Go Down On [Mme. de Cambremer]"

We will approach their exchange in *Sodom and Gomorrah*, which, by the way, is one of the best comedic moments from the entire novel, as the young Mme. de Cambremer hears Marcel speak "the name of Poussin" which "aroused the protests of the connoisseur."<sup>79</sup> On hearing Poussin's name, Mme. Cambremer smacks her tongue six times and exclaims:

In heaven's name, after a painter like Monet, who is an absolute genius, don't go and mention an old hack without a vestige of talent, like Poussin. I don't mind telling you frankly that I find him the deadliest bore. I mean to say, you can't really call that sort of thing painting. Monet, Degas, Manet, yes, there are painters if you like!<sup>80</sup>

Marcel states "she was as scrupulous as she was condescending in informing me of the evolution of her taste."<sup>81</sup> Some of the irony surrounding Proust's Mme. de Cambremer's taste, of course, originates from her name, which Elizabeth Richardson Viti explains in depth as Cambremer "is a reference to Général Cambronne who, according to the famous Waterloo anecdote, rebuffed an English officer with the epithet hinted at in the last syllable as 'le mot de Cambronne' quickly became a euphemism for the scatological term merde."<sup>82</sup> The example of the young Mme. de Cambremer and her "hirsute-lipped," "salivary hyper-secreting" mother-in-law offers Proust an opportunity to function not just as a novelist, but as a critic...a critic who assesses people like art. In the case of Mme. de Cambremer, she sees art as progress or as a forward progression where only the "now" or avant-garde matters, which, in this case, is impressionism.

Let us now return to their conversation: "Anyhow, Mme. de Cambremer went on, "I have a horror of sunsets...that's why I can't abide my mother-in-law's house, with its tropical plants."<sup>83</sup> Marcel responds to Mme. de Cambremer that "M. Degas affirms that he knows nothing more beautiful than the Poussins at Chantilly," but Mme. de Cambremer says the ones she saw in the Louvre "are hideous."<sup>84</sup> Marcel affirms that Degas "admires them immensely too," which causes Mme. de Cambremer to change her mind and respond, "I must look at them again. My memory is a bit hazy."<sup>85</sup> Mme. de Cambremer certainly intended to impress Marcel with her knowledge of art, but her enthusiasm is misplaced in dismissing Poussin. Marcel takes pleasure in rehabilitating Poussin's image for Mme. de Cambremer and then offers a lesson for the reader on taste: the day would "come when...Debussy would be...as trivial as Massenet, and the trills of *Mélisande* degraded to the level of *Manon's*. For theories and schools, like microbes and corpuscles, devour one another and by their warfare ensure the continuity of existence."<sup>86</sup> Another pivotal lesson to educate readers on perception and art is Bergotte's finale.

### "Goodbye Yellow Brick [Wall]"

Bergotte's encounter with Baroque realist painter Johannes Vermeer in *The Captive*, occurs after Bergotte read something from an art critic regarding Vermeer's *View of Delft*, a painting Bergotte adored and imagined that he knew by heart. He walks past several pictures and is "struck by the aridity and pointlessness of such an artificial kind of art" until he comes upon the Vermeer where he notices "the precious substance of the tiny patch of yellow wall" and says "That's how I ought to have written...my last books are too dry, I ought to have gone over them with a few layers of colour, made my language precious in itself, like this little patch of yellow wall."<sup>87</sup> Bergotte, in a moment of artistic self-reflection, realizes that his books were "too dry" and would have benefited from more impressions. Bergotte laments that he did not write like Vermeer's painting and even though he resolves to do better, his time is cut short as he dies just after seeing the Vermeer exhibit. Ultimately, Bergotte fails to transcend himself and receives a crushing blow from Vermeer. As Christiane Hertel has discussed, Vermeer's *View of Delft* is a masterpiece for Proust and serves as a metaphor for artistic perfection in the novel.<sup>88</sup> Why is Vermeer so important for Proust?

Proust himself provides the answer as he said that Vermeer "who keeps his back to us, who does not set store upon being seen by posterity, and who will not know what posterity thinks of him, is an admirable, poignant idea...Vermeer has been my favourite painter since age twenty."<sup>89</sup> In *Vermeer: Reception and Interpretation*, Hertel details Proust's key passages on Vermeer throughout the novel, including numerous scenes with Swann working on his essay (art criticism) on Vermeer. Regarding Swann and Vermeer, what's compelling in Swann's endeavor is the constant interruptions to his work, including an extended hiatus, which "corresponds to [Swann's] inability to detach himself from his images,



fantasies, and pictorial illusions, despite an increasingly vulnerable situation."<sup>90</sup> Swann's example here serves to educate Proust's readers as how to not read art. Vermeer's function in *Swann's Way* significantly differs from his function in the above episode from *The Captive*, as we see the excessive significance, to an allegorical extent, of the name Vermeer.<sup>91</sup> There is even a mock echo of Vermeer immediately following the Marcel-Mme. de Cambremer episode discussed previously when Mme. de Cambremer asks Albertine if she knows the Vermeers to which Albertine responds no, thinking they were living people.<sup>92</sup>

Jean-Baptiste Chardin was another artist Proust used to educate his readers on understanding art. Chardin work features commonplace items like household objects and food. Yet, as de Botton explains, "in spite of the ordinary nature of their subjects, Chardin's paintings succeeded in being extraordinarily beguiling and evocative."<sup>93</sup> Proust wrote an entire essay on Chardin, included in *Proust On Art and Literature*, which features a young man, like the narrator in the novel, who is dissatisfied, but hopes that Chardin can restore a smile to his face and, perhaps, restore his sight. Proust offers a similar "Chardin" lesson in *The Fugitive* on Venice, where he finds that art has the responsibility to give us "our impressions of everyday life" and that the "Venice of certain painters is coldly aesthetic in its most celebrated parts (let us make an exception of the superb studies of Maxime Dethomas), to represent only its poverty-stricken aspects" in order to make Venice more intimate and more genuine.<sup>94</sup> Marcel finds that some very great artists make the mistake "from a quite natural reaction against the artificial Venice of bad painters, to concentrate exclusively on the Venice of the more humble *campi*, the deserted *rii*, which they found more real."<sup>95</sup> We have documented Proust's affinity for Chardin and the related educational merits, but in this passage, Proust also mentions Dethomas, an impressionist painter, who Proust was actually friends with in real life. In Barbara Bucknall's *Critical Essays on Marcel Proust*, she explains that Proust wrote this passage after having seen Dethomas's exhibition, where Proust received a profound initiation to the understanding of nature and love of life. Proust exclaims, "It seems that one has gotten from you new eyes to look at life and men and even down to those little windows on the Grand Canal that I would love to juxtapose with yours."<sup>96</sup> This passage reaffirms Proust's affinity for "impressions of everyday life," even when he is in Venice of all places! Proust stays true to form, being interested only in the "intimate" Venice, even while riding gondolas. The aesthetic education of Proust's readers is paramount as they must possess the correct vision. Proust communicates this point in *The Captive* where he explains that the only "true voyage of discovery, the only bath in the Fountain of Youth, would be not to visit strange lands but to possess other eyes, to see the universe through the eyes of another, of a hundred others, to see the hundred

universes that each of them sees" and with men like Elstir and Vinteuil, we can "fly from star to star."<sup>97</sup> In *Time Regained*, Marcel knows that "every reader, as he reads, is the reader of himself" and that the "work of the writer is only a sort of optic instrument which he offers to the reader so that he may discern in the book what he would probably not have seen in himself."<sup>98</sup> In order to attain such discernment, Proust's readers must be able to attain the ability to understand his analogies.

## Conclusion: Art Regained

Before closing, I want to make some final observations about Proust's conscious intent in providing life lessons through patterns of relations to art and story structure. Let us consider Julia Kristeva's remark that Proust inaugurated the modern aesthetic, and established a completely new form of temporality as his novel's function is to sum up, and make explicit, the ambitions of all the novels that have gone before, through creating a distinctively new type of Bildungsroman that provides a learning process involving a return journey from the past to the present and back again.<sup>99</sup> The novel offers modern readers the chance to identify the fragments of disparate time which drags them in every direction, with a greater force and insistence than ever before.<sup>100</sup> The narrator relating his story through art gives readers exactly what they need to understand his world and to learn a proper aesthetic language.

Also worth considering, in *Time Regained*, Proust, vis-à-vis the narrator, teaches us that many people misinterpret art as they "concentrate instead upon that other ingredient in aesthetic emotion which allows us to savour its pleasure without penetrating its essence."<sup>101</sup> For Proust, many "art-lovers stop there, without extracting anything from their impression, so that they grow old useless and unsatisfied, like celibates of art...they get more excited about works of art than about real artists," because "their excitement is not the result of a laborious...study but a force which bursts outwards, which heats their conversations and empurples their cheeks."<sup>102</sup> At concerts, these same people shout "'bravo, bravo' till they are hoarse...but demonstrations of this kind do not oblige them to clarify the nature of their admiration and of this they remain in ignorance."<sup>103</sup> For Katherine Shingler, the issues surrounding the reception of art in early twentieth-century fiction reveal how the act of looking at a painting serves as a locus for the anxieties about authenticity that were so prevalent in the period.<sup>104</sup> The late nineteenth and early twentieth centuries see the rise to prominence of the connoisseur, a qualified spectator or expert in judgements of taste, as both a real and literary figure due to anxieties around the authenticity of the art object and of the aesthetic experience that it elicits.<sup>105</sup> For Proust, in order to become an artist, one must first learn the rudiments of connoisseurship.<sup>106</sup>

Many of Proust's characters serve as case studies to teach readers how not to view art and to warn us that art is not something just to be bought and sold, serving no aesthetic pleasure, as a convenient vehicle to ensure one's social standing. Given this framework, Proust uses his novel to educate his readers on how and how not to be connoisseurs. Proust equips his readers with the armor of art in the pursuit of truth as "the truth is that as soon as the reasoning intelligence takes it upon itself to judge works of art, nothing is any longer fixed or certain: you can prove anything you wish to prove."<sup>107</sup> Marcel concludes that the aesthetic judgements of high society rest on a negation of true taste. For the high society characters, their "problem is that in all of their aesthetic pontifications one can find no genuinely felt impression: Proust's consumers of art bypass the impression — the act of looking — as the basis of their aesthetic judgements."<sup>108</sup> The cases I have mentioned previously with Mme. Verdurin, the Guermantes, Mme. Cambremer, and Bergotte, show examples where "spectatorship never takes place because the spectator is simply not willing to look at the type of art in question."<sup>109</sup> For Proust, art meant an awareness of not only our own lives, but, as we read in *Time Regained*, an "awareness of the lives of other people ...a question not of technique but of vision...the revelation" and is "the uniqueness of the fashion in which the world appears to each one of us, a difference which, if there were no art, would remain for ever the secret of every individual."<sup>110</sup> As Proust's narrator criticizes the modes of art consumption adopted by his high society acquaintances, he does not speak from a position of authority: time and time again, his own spectatorship is revealed to be flawed.<sup>111</sup>

Proust's greatest lesson involves his narrator as we see Marcel's preconceptions distorting his experience with works of art, meaning he does not see them for what they are—how not to look at art—until he finally completes, with his readers in tow, his aesthetic education. Unlike Swann, seemingly the ultimate connoisseur, who can, in the same moment, readily attribute a painting to its author but also fail to enjoy the art, Marcel succeeds in both endeavors. While Marcel is a success story, Proust stops short of telling readers how to set about examining our own aesthetic impressions as "the art of looking cannot be taught by numbers, and we are ultimately left, as spectators, to the devices of our own subjectivity."<sup>112</sup> Yet, *In Search of Lost Time* provides readers important life lessons through perception and art to follow. Proust leaves the matter to us to contemplate as he addresses this very point in the final volume of his novel in *Time Regained* as he, and his narrator, finally provide readers his truth and purpose as art exactly reconstitutes life, around "the truths to which we have attained inside...we have to traverse, the indication...of the depth of a work...the work of art was the sole means or rediscovering Lost Time" and, if given enough time to accomplish his work of art, he will "describe men as occupying so considerable a place...a place on the contrary prolonged past measure...in Time."<sup>113</sup>

## Author Biography

J. Philippe Thompson is an Adjunct Professor of English at California Lutheran University (CLU) and of Humanities at Pepperdine University with interests in modernism, world literature, art history, visual culture, and science fiction. Before arriving at CLU and Pepperdine, Thompson taught at the Graziadio Business School, AMDA College and Conservatory of the Performing Arts (in Hollywood), and Florida Gulf Coast University. He is currently completing a Ph.D. in English from Claremont Graduate University.  
Email: j.philippe.thompson@gmail.com OCID: 0000-0002-7616-8681

## Notes

1. *Marcel Proust On Art and Literature: 1896-1919* (Carroll & Graf Publishers, Inc., 1954).
2. *The Notebooks of Leonardo da Vinci*, Vol. 1, translated by Edward Mac-Curdy (Braziller, 1947).
3. Vincent Descombes, *Proust: Philosophy of the Novel* (Stanford UP, 1992), 241.
4. Descombes, *Proust: Philosophy of the Novel*, 510.
5. Descombes, 241.
6. Descombes, 574.
7. Hans Robert Jauss, *Toward an Aesthetic of Reception*. Trans. by Timothy Bahti. (*Theory and History of Literature*, Vol. 2. U of Minnesota P, 1982).
8. Walter Benjamin, "Theses on the Philosophy of History" (*Illuminations*. Random House, 1968), 255.
9. Benjamin, 214.
10. Eric Karpeles, "Paintings in Proust" (*New England Review*, Vol. 29, No. 3. Middlebury College Publications, 2008), 43.
11. Karpeles, 43.
12. Karpeles, 232.
13. Karpeles, 237.
14. Karpeles, "Paintings in Proust," 44. In considering Proust's own drawings, Françoise Leriche notes we can see the same foibles he denounces in Swann at times in his novel; yet, Proust's critical, or meta-critical, eye in his caricatures helps us to question what we see in works of art. Leriche, Françoise. "Proust's Eye." *Proust and the Arts*, edited by Christie McDonald and François Proulx (Cambridge UP, 2015), 164.
15. Jonathan Crary, *Suspensions of Perception: Attention, Spectacle, and Modern Culture* (MIT Press, 1999), 12.
16. Crary, 12.
17. Crary, 51.
18. Mary C. Rawlinson, "Proust's Impressionism." (*L'Esprit Créateur*, Vol. 24, No. 2, *Literature and Perception*. The John Hopkins UP, 1984), 80-82.
19. Rawlinson, 91.
20. *Within a Budding Grove*, 533.
21. Rawlinson, "Proust's Impressionism," 88.
22. Rawlinson, 89.
23. Gérard Genette, *Narrative Discourse: An Essay in Method*. Translated by Jane E. Lewin (Cornell UP, 1980), 102.
24. Genette, 102-103.

25. Genette, 570.
26. Roger Shattuck, *Proust's Binoculars: A Study of Memory, Time, and Recognition in A la recherché du temps perdu*. Princeton UP, 1983. 6. Roger Shattuck's *Proust's Way: A Field Guide To In Search of Lost Time* (2000) is also an excellent resource.
27. Shattuck, 6.
28. Shattuck, 10.
29. Shattuck, 137.
30. Gilles Deleuze, *Proust & Signs: The Complete Text* (U of Minnesota P, 2000), 16. Deleuze also states that art is explained by pure thought as a faculty of essences on p. 55.
31. Deleuze, 605.
32. Deleuze, 606.
33. Deleuze, 206.
34. Deleuze, 802-803, 814.
35. *The Fugitive*, 590.
36. *The Captive*, 180.
37. Deleuze, 227.
38. Deleuze, 227-228.
39. Deleuze, 235, 336.
40. Deleuze, 510.
41. Deleuze, 155.
42. Martha Wiseman, "Waking to the Night: Proust's Dream Theater." *Marcel Proust Aujourd'hui*, Vol. 2, Mille et une nuits dans La Recherché (Brill, 2004), 84.
43. Deleuze, 85.
44. Deleuze, 86.
45. Deleuze, 88.
46. Deleuze, 90.
47. Deleuze, 4-6, 9.
48. Shattuck, *Proust's Binoculars: A Study of Memory, Time, and Recognition in A la recherché du temps perdu*, 6.
49. Shattuck, 98.
50. Shattuck, 98-99.
51. Shattuck, 99.
52. Shattuck, 99.
53. Shattuck, 97.
54. Evelyne Ender and Serafina Lawrence, "Inside a Red Cover: Proust and the Art of the Book." *Proust and the Arts*, edited by Christie McDonald and François Proulx (Cambridge UP, 2015) 192.
55. Ender and Lawrence, 192.
56. Ender and Lawrence, 192.
57. Ender and Lawrence, 192.
58. Ender and Lawrence, 288.
59. Ender and Lawrence, "Inside a Red Cover: Proust and the Art of the Book," *Proust and the Arts*, 193.
60. Art for art's sake. Théophile Gautier was the first individual to use this phrase as it appeared in the preface to his *Mademoiselle de Maupin* (1835).
61. Shattuck, *Proust's Binoculars: A Study of Memory, Time, and Recognition in A la recherché du temps perdu*, 134.

62. *Within a Budding Grove*, 652.
63. Shattuck, 263.
64. Shattuck, 264.
65. Shattuck, 264-265.
66. Shattuck, *Proust's Binoculars: A Study of Memory, Time, and Recognition in A la recherché du temps perdu*, 143.
67. *The Guermantes Way*, 574.
68. Shattuck, 574.
69. Shattuck, 574.
70. Alain de Botton, *How Proust Can Change Your Life* (Vintage, 1997), 101-135
71. Alain de Botton, 217.
72. *The Captive*, 217.
73. Alain de Botton, 679, 685, 687.
74. Alain de Botton, 686-687.
75. Alain de Botton, 718.
76. Alain de Botton, 718.
77. Alain de Botton, 718.
78. Alain de Botton, 787.
79. Alain de Botton, 285.
80. Alain de Botton, 285.
81. Alain de Botton, 285.
82. Elizabeth Richardson Viti, "Le Mot de Cambronne: An Excremental Exclamation and its Implication in *A La Recherché du Temps Perdu*." *Romance Notes*. U of North Carolina, 1996. 139.
83. *Sodom and Gomorrah*, 286.
84. Richardson Viti, 287.
85. Richardson Viti, 287.
86. Richardson Viti, 291.
87. Richardson Viti, 244.
88. Christiane Hertel, "The Modern Vermeer: Marcel Proust's *Remembrance of Things Past*." *Vermeer: Reception and Interpretation* (Cambridge UP, 1996), 93.
89. Hertel, 102-103.
90. Hertel, 104.
91. Hertel, 104.
92. Hertel, 105.
93. de Botton, *How Proust Can Change Your Life*, 135.
94. de Botton, 848.
95. de Botton, 848.
96. Barbara Bucknall, *Critical Essays on Marcel Proust*. (G.K. Hall, 1987), 178. Bucknall's selection comes from a letter from Proust to Dethomas, an influential artist who also designed sets and costumes.
97. Bucknall, 343.
98. Bucknall, 172.
99. Julia Kristeva, "Proust and Time Embodied." *Bloom's Modern Critical Views: Marcel Proust*, edited by Harold Bloom (Chelsea House Publishers, 2004), 17.
100. Kristeva, 18.
101. Kristeva, 292.
102. Kristeva, 293.
103. Kristeva, 292-293.

104. Katherine Shingler, "Art and Connoisseurship in Bourget and Proust." *The French Art Novel: 1900-1930* (Modern Humanities Research Association, Legenda, 2016), 16.
105. Shingler, 16.
106. Shingler, 25.
107. *Time Regained*, 295.
108. Shingler, "Art and Connoisseurship in Bourget and Proust," *The French Art Novel: 1900-1930*, 28.
109. Shingler, 28.
110. Shingler, 299.
111. Shingler, "Art and Connoisseurship in Bourget and Proust." *The French Art Novel: 1900-1930*. 29.
112. Shingler, 39.
113. *Time Regained*, 302, 304, 531-532.

## Bibliography

- Benjamin, Walter. "Theses on the Philosophy of History." *Illuminations*. Random House, 1968.
- Bucknall, Barbara. *Critical Essays on Marcel Proust*. G.K. Hall, 1987.
- Crary, Jonathan. *Suspensions of Perception: Attention, Spectacle, and Modern Culture*. MIT Press, 1999.
- de Botton, Alain. *How Proust Can Change Your Life*. Vintage, 1997.
- Deleuze, Gilles. *Proust & Signs: The Complete Text*. U of Minnesota P, 2000.
- Descombes, Vincent. *Proust: Philosophy of the Novel*. Stanford UP, 1992.
- Ender, Evelyne, and Serafina Lawrence, "Inside a Red Cover: Proust and the Art of the Book." *Proust and the Arts*, edited by Christie McDonald and François Proulx. Cambridge UP, 2015.
- Genette, Gérard. *Narrative Discourse: An Essay in Method*. Translated by Jane E. Lewin, Cornell UP, 1980.
- Hertel, Christiane. "The Modern Vermeer: Marcel Proust's *Remembrance of Things Past*." *Vermeer: Reception and Interpretation*. Cambridge UP, 1996.
- Jauss, Hans Robert. *Toward an Aesthetic of Reception*. Trans. by Timothy Bahti. *Theory and History of Literature*, Vol. 2. U of Minnesota P, 1982.
- Karpeles, Eric. "Paintings in Proust." *New England Review*, Vol. 29, No. 3. Middlebury College Publications, 2008.
- Kristeva, Julia. "Proust and Time Embodied." *Bloom's Modern Critical Views: Marcel Proust*, edited by Harold Bloom. Chelsea House Publishers, 2004.
- Leriche, Françoise. "Proust's Eye." *Proust and the Arts*, edited by Christie McDonald and François Proulx. Cambridge UP, 2015.
- Rawlinson, Mary C. "Proust's Impressionism." *L'Esprit Créateur*, Vol. 24, No. 2, *Literature and Perception*. The John Hopkins UP, 1984.
- Richardson Viti, Elizabeth. "Le Mot de Cambronne: An Excremental Exclamation and its Implication in *A La Recherché du Temps Perdu*." *Romance Notes*. U of North Carolina, 1996.
- Shattuck, Roger. *Proust's Binoculars: A Study of Memory, Time, and Recognition in A la recherché du temps perdu*. Princeton UP, 1983.
- Shingler, Katherine. "Art and Connoisseurship in Bourget and Proust." *The French Art Novel: 1900-1930*. Modern Humanities Research Association, Legenda, 2016.
- Wiseman, Martha. "Waking to the Night: Proust's Dream Theater." *Marcel Proust Aujourd'hui*, Vol. 2, Mille et une nuits dans La Recherché. Brill, 2004.

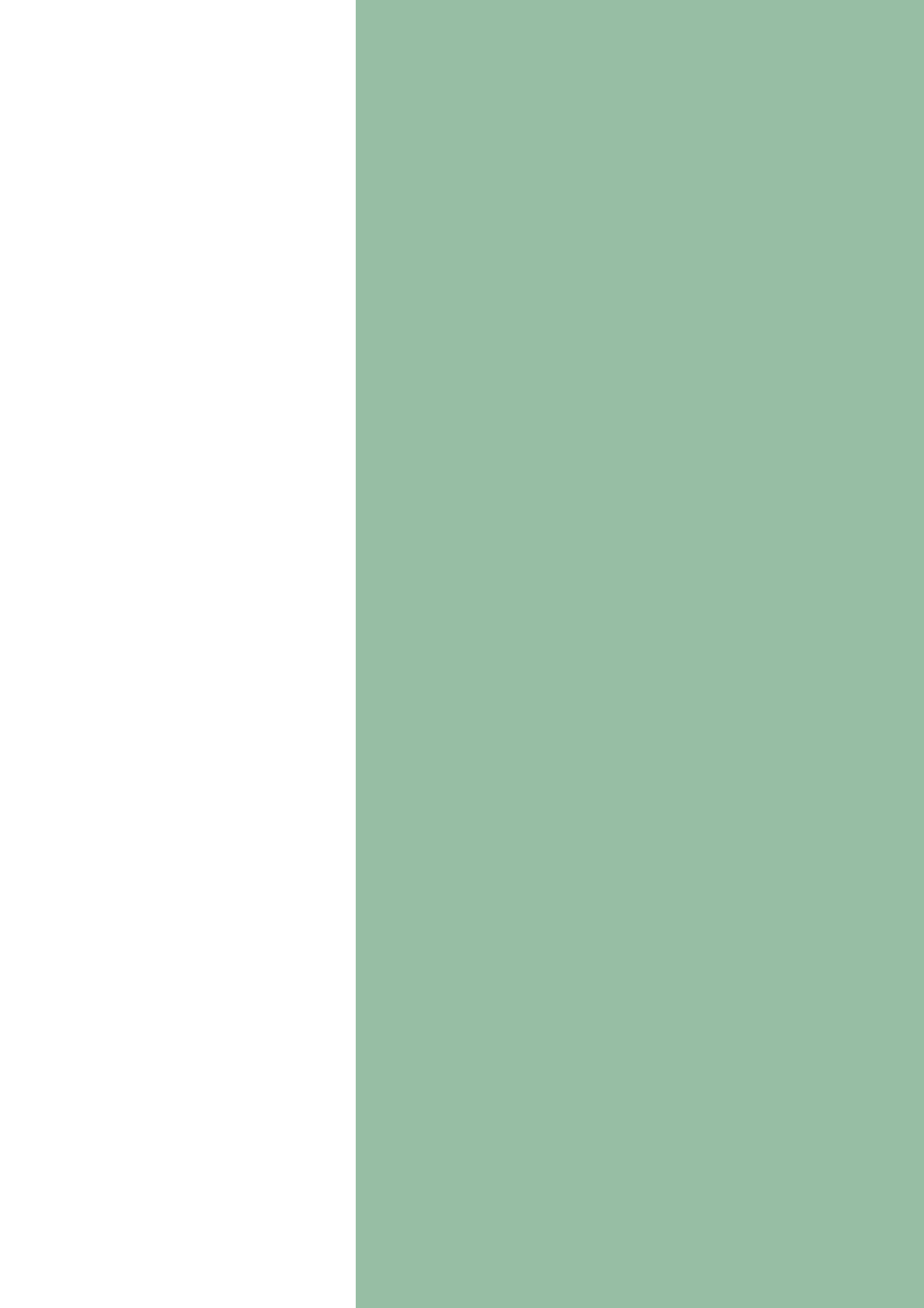





# Philippe Parreno and the Exhibition as a Multimodal Aesthetic Experience

Hans Dieter Huber

## Abstract

A mode is how something is. Modality is the possibility of an object, person or event to be in a certain way. Multimodality is the possibility of being many things at the same time. Perception is not a passive reception of stimuli, but an enactive, embodied and embedded action. Through perceptual action, actors create the presence and absence of their lifeworld. Perception functions in a multisensory way and with all senses simultaneously. This advantage is that information from different sensory channels about the same object or event can be better integrated. The event or object can therefore be identified more quickly and reliably. The information from individual sensory channels is synchronously integrated in different brain areas. In multisensory integration, the brain has to fulfil two tasks simultaneously. It must bring together the different sensory informations that come from the same object or event and it must separate and distinguish the informations that come from other objects or events. Using the example of two extensive exhibition installations by the French artist Philippe Parreno, it will be shown how the multimodality of perception and action can be transferred to algorithmic or biological machines that are able both to register and process sensory inputs and to carry out motor controls in the objects of the exhibition. In this context, Philippe Parreno has developed a new form of choreographed exhibition. In it, individual artworks are no longer lined up next to each other. His exhibitions function as hyperobjects. They are controlled by various multimodal sensory inputs, algorithmic intelligences or biological organisms and its motor output. They trigger the behaviour of the exhibition objects, make certain forms appear temporarily and make others disappear again. His art is an example of how not only the aesthetic experience of the exhibition visitors functions multisensory, but also how the choreography of the exhibition functions multimodally.

## Introduction

The text presented here brings together two different lines of thought that have already been prepared and developed in several earlier publications by the author.<sup>1</sup> The first idea is that experiences that someone has when visiting an exhibition are made with all senses and the whole body. Aesthetic experiences are a form of active, explorative action that explores the environment. The second line of thought has developed from an intense engagement with the work of the French artist Philippe Parreno. He choreographs exhibitions as a deliberate sequence of aesthetic experiences, as a scripted space<sup>2</sup> containing various time codes along which objects appear, are set in motion, change their behaviour or disappear again. The behavioural changes are triggered by environmental events or by the behaviour of biological organisms. The choreography of his exhibitions is multimodal (Figure 1). It engages the senses of the exhibition visitor in different ways, at different times and in different places in the exhibition. Parreno is an artist who does not simply string together individual works in different rooms chronologically or thematically, but conceives of the entire exhibition park as a score, symphony, choreography or scripted space through which viewers are guided in a non-authoritarian manner. The exhibition as a whole becomes a hyperobject<sup>3</sup> in which individual works stand in relation to an overarching spacetime choreography and to the social group of exhibition visitors.



Figure 1. *Exhibition view Hyundai Commission 2016: Philippe Parreno: Anywhen, Tate Modern, Turbine Hall, London, 2016 - 2017. Courtesy of the artist; Pilar Corrias, London; Gladstone Gallery, New York; Esther Schipper, Berlin. Photo © Andrea Rossetti*

People enter into a time zone where they are exposed to things in a sort of a non-authoritarian way. You don't know exactly what will happen if you enter an exhibition space. And then you may miss something, a form appears and disappears. My work is all about that. Trying to set up the condition in which the form that exists starts to dissolve. And that flickering effect between being and not being produces in a way these synchronicities where you can encounter a person or a person can encounter a form. I start sometimes in an exhibition looking at people looking. When we open a show I stay with that show. I don't leave the day after. I stay and I start to understand the way it functions. Because it's a creature, it functions. And sometimes it doesn't really function yet. It has to be tuned a little bit. And the show also changes over time. That happened in the Tate. It changed over time. It is very nice to be in the space with people looking at things. It is the only time when they can see it. I sit when people sit. Before that it doesn't exist. It only exists on paper. It has to exist in the space when it plays and lives.<sup>4</sup>

## Definitions

If one wants to talk about multimodality, it seems reasonable to first clarify what is meant by the term's mode, modality and multimodality and then to ask whether modes or modalities are given or generated. A mode is the way something is. One can distinguish many types of modes from each other. A temporal mode, a spatial mode and a social mode of being. The concept of modality represents a linguistic specification of the mode concept, which shifts the meaning to another aspect. By modality we understand the possibility of an object, a person or an event to be in a certain mode. A modality is thus the way in which objects are potentially given and currently appear or are brought forth. The concept of modality is more strongly linked to the concepts of potentiality, actuality and necessity than the concept of mode, which rather denotes the actual state of an object.

If an object is given in temporal mode, it concerns its embeddedness in the present, the past or the future. An object can be temporally related to the past. Then it is given in the mode of memory. But it can also be temporally connected with the present of an observer. Then the object is given in the mode of presence. If the object is modally connected to the future, then it is an expectation. In spatial terms, spatial modes can be positional relations in relation to an observer, i.e., front, bottom, top, side or back. The social mode of an object is determined by its use by others. The moment certain objects are used for purposes and actions, the object is in a social mode.

Multimodality usually refers to the use of different modalities for communication in the form of visual, acoustic or linguistic media. If a particular communication system uses more than one sensory channel for communication, for example, vision and hearing, it is multimodal. This also applies to the sensory channels of human perception. Normally, actors use all senses for their orientation in everyday life, which they integrate into a unified spacetime experience.

So far, we have not said anything about whether a mode is given or produced by an observer. Does it exist, as some theories assume, as a property in the object itself, independent of any observation, handling and use? Or do modes and modalities only emerge through observers, actors or agents who generate different aspects of objects through their distinctions and judgements and act with them in different situations? For me, modes and modalities only emerge through an observer who distinguishes different aspects of an object, to be, and designates them linguistically or figuratively. From there, there are an infinite number of modes or modalities of an object. There are as many as an observer can distinguish, discriminate and use. It is impossible to predict from the object how its modality should be possible in and of itself without a discriminating and signifying observer. We can never perceive the object "in itself". For this would presuppose the possibility of being able to form an infinite and complete series of all appearances or views of an object.<sup>5</sup>

If we transfer these considerations about the multimodality of objects into art, we realise that the way a work of art is depends on how it is distinguished, perceived and interpreted by an observer. In art, in addition to a temporal, spatial and social mode, there is also an aesthetic mode a work of art or a design object can be. This mode is created by the aesthetic attitude of an observer. Thus, when one speaks of the multimodality of art, one points out that art objects are not given in only one way, but in many different and possible ways. This forces us to turn more closely to the question of how observers observe, create differences, evaluate and thus generate the specific modalities of art.

## Modes of Perception

Perception itself is always multimodal. Every human being perceives simultaneously through all his senses at any time of his life, unless he is impaired by a disease of one of the sensory channels. What role do the senses play in the constitution of a multimodal object?

It is still a widespread assumption that perception is something passive, something we take in through our eyes, ears or noses, something that enters us, something that happens or happens to us. It is often said that perception is a reception of sensory data or stimuli.

But it must be said clearly that nothing is “taken in” by the senses. It is a translation. All sense systems are operationally closed systems.<sup>6</sup> The direct absorption of a perceptual object into our organism would lead to a physical destruction of the organs of perception. Therefore, a medium is necessary that mediates between the objects of perception and the sense organs. The intervening ambient medium translates certain properties of the object of perception into the properties of the ambient medium, such as coloured structured light, structured pressure differences or unevenly distributed gas molecules. In perception, therefore, it is not the object “itself” that is perceived, but the structured dynamics of the surrounding medium. These are perceived. On the closed sensory surfaces of living systems the states and events of the surrounding media are translated into the discontinuous code of synaptic discharges.

### Perception as Active Action

We must therefore describe perception as an autonomous self-activity of a living system. But that is not enough. For perception is not just an activity or a behaviour. Perceiving is acting, acting with the whole body, with the legs, the arms, the upper body and the head. When we want to perceive a work of art more closely, not only all our senses work together. Our motor apparatus is also active. We approach an art object through our body movements, scrutinise its presence and appearance by stepping back and forth or to the side to observe it more closely in its surrounding. In doing so, we have visual, acoustic, haptic, olfactory and proprioceptive perceptions.

### Perception as Embodied Action

Every perception of objects, events or persons is embodied. Perception in an environment is accompanied by a perception of one’s own position, movement and inner, somatosensory states. There is no perception of the world without an environmental medium and without a body. One cannot perceive the world without simultaneously perceiving oneself. By shifting attention to ourselves, we notice that our body is not only a constant companion, but also the condition of the possibility of self-perception and perception of the world. When we turn our attention to the outside world, somatosensory self-perception runs along as the unconscious background of perceptual action. There is no world-perception without self-perception and no self-perception without world-perception. The world and the self are structurally coupled in sensorimotor action.

### Perception as Embedded Action

Embodied, sensorimotor action takes place in a specific lifeworld. The perceiving and acting body is not only embedded in various environmental media. It acts in a continuous *structural coupling* with its environment.<sup>7</sup> A closed operating system

such as a living organism can only do what it does, for example perceiving, acting, feeling or thinking, within the boundaries of its own body. The operations of a living system are only possible within that system. No system can operate outside its own boundaries. On the other hand, closed systems must also be structurally coupled with their environment in certain respects. The environment provides the living organism with resources such as oxygen, heat or food as affordances.<sup>8</sup> If the structural coupling of a living organism to its environment falls away, this means the death of the living being.

## The Production of Presence and Absence

Through embodied, embedded and enactive action, world and self become present. The presence of things, events or other persons depends on the sensorimotor contingencies of the actors.<sup>9</sup> For the action of an actor is always possible in another way. Decisions to act are always surrounded by alternative possibilities for action in a situation. The presence of the world and the self is brought about by sensorimotor skills. Sensorimotor action is a form of performative world production.<sup>10</sup>

Each production of presence through sensorimotor action splits the world into two parts, an accessible and an inaccessible part, a present and absent part of the world. Since every perception of the world simultaneously implies self-perception and vice versa, the argument can be extended accordingly. Through the production of presence, the self is also split into two parts, namely one accessible to self-perception and one inaccessible to it. Presence is the sensorimotor production of the accessibility of world and self. Absence, on the other hand, is the sensorimotor production of the inaccessibility of world and self. Actors create presences and absences of objects, events or other persons by making them appear or disappear in a situation through their active actions and sensorimotor skills. The specific relation of presence and absence is always temporary and can change from moment to moment. An object becomes present when it is produced as an object by the sensorimotor skills of an actor. Those things or parts of objects become absent that cannot be produced with the specific sensorimotor skills of an actor.

The relationship of a living and acting organism to the world and to itself is therefore primarily a question of its sensorimotor skills. Depending on these particular skills, a unique access to the things of the world and to itself opens up for the living being. This access depends on sensorimotor skills, which one has acquired in the course of life through experience, routine or training. In the case of limited sensorimotor skills, such as a physical handicap, access to the world and to oneself can also be limited or altered.

To be able to access the world through our sensorimotor skills, we need media. The difference between presence and absence is therefore always a difference created through media. It is never direct, immediate or given. On the one hand, it is generated by the biological media of sensory systems and body motor skills, and on the other hand, it is extended by technical media. The sensorimotor skills and technologies of an actor are the condition of possibility for the production of presence and absence within his or her current range.<sup>11</sup> Presence is thus firstly actively generated, secondly embodied and thirdly embedded into a specific lifeworld.<sup>12</sup>

## The Multisensory Integration of Perceptual Action

The way we conceive of the world and ourselves is based on our sensory experiences.<sup>13</sup> Perceptual research has been dominated in the past by research approaches that isolated individual senses, such as vision or hearing, from its association with other senses and focused its attention on the functional properties of these isolated sensory modalities. However, there is no doubt that our senses are structured to function together and that our brain uses the neural activity patterns it receives from different sensory channels in a cooperative manner. This increases the likelihood that objects, people or events can be perceived more quickly and identified more correctly. The collaborative use of all available sensory channels is a strategy that has a high survival value, which is crucial for the evolution of species.<sup>14</sup> It is therefore not surprising that multimodal processing of neuronal signals can be observed in virtually all animal species.

Everyday perception generates a constant stream of sensory perturbations that hits all sensory channels simultaneously. The brain's task is now, on the one hand, to sort these massive and diverse neuronal signals and to connect those that should be related to each other regardless of their respective sensory modality because they originate from a common event or object. At the same time, however, the brain must also separate those signals that originate from different perceptual events or objects. In multisensory processing, therefore, the brain has to perform two tasks simultaneously, namely to relate those perturbations that describe one and the same perceptual event and to separate those signals that relate to other perceptual events.

Deciding what is perceived as a single object or as a related event is an operation that requires a synthesis of different perturbations originating from different sensory channels. Multisensory convergence can amplify the parts of individual sensory modalities so that they become dominant. But it can also suppress or weaken them.



Certain sensory modalities can be processed entirely without involvement of the conscious mind, which means, that they are processed and integrated unconsciously. However, multisensory integration in the brain is not limited to sensory processing. Rather, it is a fundamental process of the brain that also occurs in areas traditionally thought of as cognitive or motor domains.<sup>15</sup>

Three principles guide the multisensory integration of sensory information. First, *the temporal rule*. It states that maximum multisensory integration occurs when the different unimodal stimuli that constitute the perturbation are presented at the same time. Second, *The spatial rule* states that maximum multisensory integration occurs when stimuli from different sensory modalities originate from the same location. The third principle of sensory integration is the *principle of reverse effectiveness*. Maximum multisensory integration occurs when at least one of the unisensory inputs in the excitation of a neuron is only weakly effective.<sup>16</sup>

## Multimodal Aesthetic Experiences

In traditional aesthetic situations like in a museum or an exhibition, the viewer is usually faced with aesthetic objects such as paintings or sculptures. They are separated from the wall, the floor and the ceiling by a frame or a closed form. It is often additionally emphasised by special lighting. The viewer constitutes the aesthetic object through his multisensory perceptual activity. He apprehends, creates, interprets and judges it. Based on his previous experiences, he knows that in most cases it is not about the smell of the painting, unless it is an exhibition by Sissel Toolas, or about the sounds made by other actors. In a traditional aesthetic experience, he purposefully fades out those senses that are not relevant to the experience and, in the multisensory integration of the incoming activity patterns, gives the sense of sight priority over the other sensory channels.

As exhibition visitors we always go to an exhibition with all our senses and all our physical equipment. Every visit to an exhibition is therefore fundamentally multisensory. It takes place with all our senses simultaneously. The various unimodal activity patterns of the neurons, which converge in different areas of the brain, are integrated into a unified spacetime experience. Their relevance to the aesthetic experience can be of varying importance and lead to a different weighting of the individual sensory modalities. Something fundamentally different happens, however, when the exhibition itself, is not an addition of artworks but is, as a whole, the aesthetic object to be produced by the exhibition visitor.

## Exhibitions as Scripted Spaces

In recent years, the French artist Philippe Parreno has repeatedly staged exhibitions as unified aesthetic objects that address the different sensory channels of the visitors at different times, in different places and in different ways.<sup>17</sup> In 2019, Philipp Parreno realised an extensive installation in the entrance lobby of the Museum of Modern Art in New York, in which he used complex machinery to control the individual elements.<sup>18</sup> It is entitled *Echo*, which on the one hand refers to the reverberation that occurs when the reflections of a sound wave are delayed by more than 20 milliseconds and are thus perceived as a separate auditory event. But the work also alludes to the name of a mountain nymph from Greek mythology who distracts the goddess Juno with her chatty talk while Jupiter pursues his amorous adventures. She is therefore punished by Juno in such a way that when someone is silent, she is neither the first to speak, nor when someone speaks, she is silent.<sup>19</sup> Parreno has transferred this paradox to a complex machinery. It cannot become active by itself in silence. But on the other hand, it cannot remain silent either as soon as certain parameters of the environment change.

The installation is equipped with numerous sensory devices. Air pressure, humidity, temperature, sounds and the number of visitors in the lobby are registered. On the roof of the museum, cloud cover and wind direction are measured, including changes in the steel structure of the building. This sensory data is transmitted to a complex computer network that can process these signals. They are used to generate a series of non-periodic and unpredictable visual and acoustic events using a random algorithm. The behaviour of the *Echo* installation is based on the various sensory inputs that the algorithmic automaton receives in real time from its immediate environment, converts into DMX signals, which then control the individual units of the installation and change their behaviour.<sup>20</sup> *Echo* thus responds in a multisensory and multimotor way to its environment, through various objects placed in the lobby. The installation consists of two movable, highly directional speakers, a large *marquee* suspended from the ceiling and a smaller *marquee* mounted on the wall above a mirrored chrome *shutter* that opens, closes or remains in a partially open state. Both *marquees* play different light sequences that depend on the sensory input. In addition, the ceiling and wall lamps mounted in the foyer go on or off irregularly or sometimes flicker as if electric power is breaking down or the light bulb is going wrong. Furthermore, a screen has been mounted on which coloured lights and various films by Philippe Parreno can be projected. These different units are coordinated and articulated by the computer network.<sup>21</sup>

In 2020, the MoMA work was complemented by a new work, *Echo Radio* and its internet variant *echo.world*, in which Parreno used a newly created artificial intelligence to control the soundtrack. He asked Alejandra Ghersi, stage name Arca, a Venezuelan non-binary musician, to develop a soundtrack for the automaton.

Arca proposed to work with experimental *granular synthesis*. Granular synthesis works in a similar way to film, where the rapid succession of static frames creates the cognitive experience of movement in the human brain. In granular synthesis, a continuous sound is perceived, but in reality it is composed of individual micro-particles, some of which are below the time duration for the complete cognitive processing of a single, definable sound event. These micro-elements, the so-called *grains*, consist of very short or even longer digital sound fragments whose duration is usually between 10 and 100ms.<sup>22</sup> The method of granular synthesis offers, among other things, the advantage that the speed can be varied independently of the pitch.<sup>23</sup>

For the realisation of *echo. world's* soundtrack, a newly developed artificial intelligence called *Bronze* was used, which enables musicians to compose music that is generative rather than static. It was developed in 2019 by London-based musicians Lexx and Gwilym Gold and scientist Mick Grierson.<sup>24</sup> Every time you hear the piece *echo.world*, it sounds different. The units run through the AI system and produce constantly changing new versions of the piece. Every time you play the soundtrack, it's a new version, performance, mix or performance put together by the AI.<sup>25</sup> It creates an abstract, three-dimensional space that symbolises the space of the automaton.<sup>26</sup> On the one hand, *Echo Radio* and *echo.world* react to the external inputs of the sensory system at MoMA. On the other hand, they also rest within themselves in a nocturnal state that is triggered when there is no longer an audience in the museum. During this time, the soundtrack is transmitted to the city via an FM radio station.

## Controlled by Biological Organisms

In 2018, Philippe Parreno installed, among other objects, a bioreactor in his exhibition at the Gropius-Bau in Berlin (Figure 2).<sup>27</sup>



Figure 2: Philippe Parreno, Exhibition view, Gropius Bau, Berlin 2018. Bioreactor and probes, peristaltic pump, scales, air compressor, air filter, silicone hose and seals, electrical devices, servo controller, plexiglass box. On the walls: Wallpaper Marilyn, 2018 Fluorescent ink on paper, dimensions variable. Courtesy of the artist; Pilar Corrias, London; Gladstone Gallery, New York; Esther Schipper, Berlin. Photo © Andrea Rossetti.

This complex input-output system, which is in a homeostatic equilibrium, is set up in a display case like in a natural science museum. One can view the bioreactor from all sides and follow its functioning in real time. In the showcase, which is freely accessible from all sides, there is a table on which a large number of objects are placed. In the middle stands the glass bioreactor, which is equipped with a series of measuring sensors. These sondes provide data on various process parameters. Above the reactor are two large Duran glass bottles, which are connected to the reactor by tubes. They contain a yellowish medium that can be pumped into the reactor by means of peristaltic pumps. In the glass reactor itself, the yeast cultures live in a liquid medium. Yeast are single-cell organisms whose DNA is very similar to our human DNA. As a scientific or aesthetic observer, one initially thinks one is confronted with an experimental set-up. However, it takes explorative curiosity to understand how this system works. You are confronted with a wired, living organism - a sympoietic machine (Figure 3).<sup>28</sup>

To the left of the bioreactor are four peristaltic pumps on height-adjustable pedestals, which, depending on the internal state of the yeast-medium mixture, supply the glass bottle with certain substances such as medium, vitamins and micronutrients, or acid and lye to maintain the pH value of the medium. Basically, in order to grow and reproduce, yeast needs a certain pH value and temperature in addition to nutrients and oxygen. As it grows and reproduces, it absorbs the nutrients in the medium, metabolises them and excretes so-called metabolites, as well as CO<sub>2</sub>, into the medium. If the system were left to itself, the yeast would eventually have metabolised all its nutrients, so that no more nutrients, vitamins or medium would be available. The yeast would starve. Therefore, nutrients have to be supplied. However, the production of metabolites would also lead to the accumulation of toxic substances in the medium, the yeast would poison itself. Therefore, parts of the medium have to be removed from the bioreactor by means of peristaltic pumps and replaced by fresh medium. In addition, the release of CO<sub>2</sub> into the medium leads to a lowering of the pH value, which in turn affects the vitality of the yeast cells. This is prevented by adding lye to the medium. To maintain the system, one must therefore continuously monitor and supervise the entire conditions by measuring critical process parameters. The data is collected and the process is controlled by means of process software installed on the computer on the right of the picture.

The probes in the glass bioreactor are used to measure various parameters such as optical density (OD<sub>600</sub>), reduction potential (RedOx), oxygen partial pressure (pO<sub>2</sub>), pH value and temperature (Figure 4). If the pH value exceeds or falls below predefined target parameters, the programme controls the countermeasures. If, for example, the pH falls below a certain value, lye is added by a peristaltic pump to make the medium, which is becoming increasingly acidic due to the yeasts' food intake and excretions, more basic again and thus in turn to stimulate the yeast's reproduction rate. Parreno says that one can influence this system by two measures, by adding or withdrawing nutrients. Both measures change the state of the biochemical system and thus the behaviour of the yeast cultures. In addition, one can influence the yeast cells by specifically manipulating the environmental conditions. If, for example, the temperature and/or the oxygen partial pressure increase and/or the pH value is adjusted to a more basic value, the yeast begin to bud and produce daughter cells.

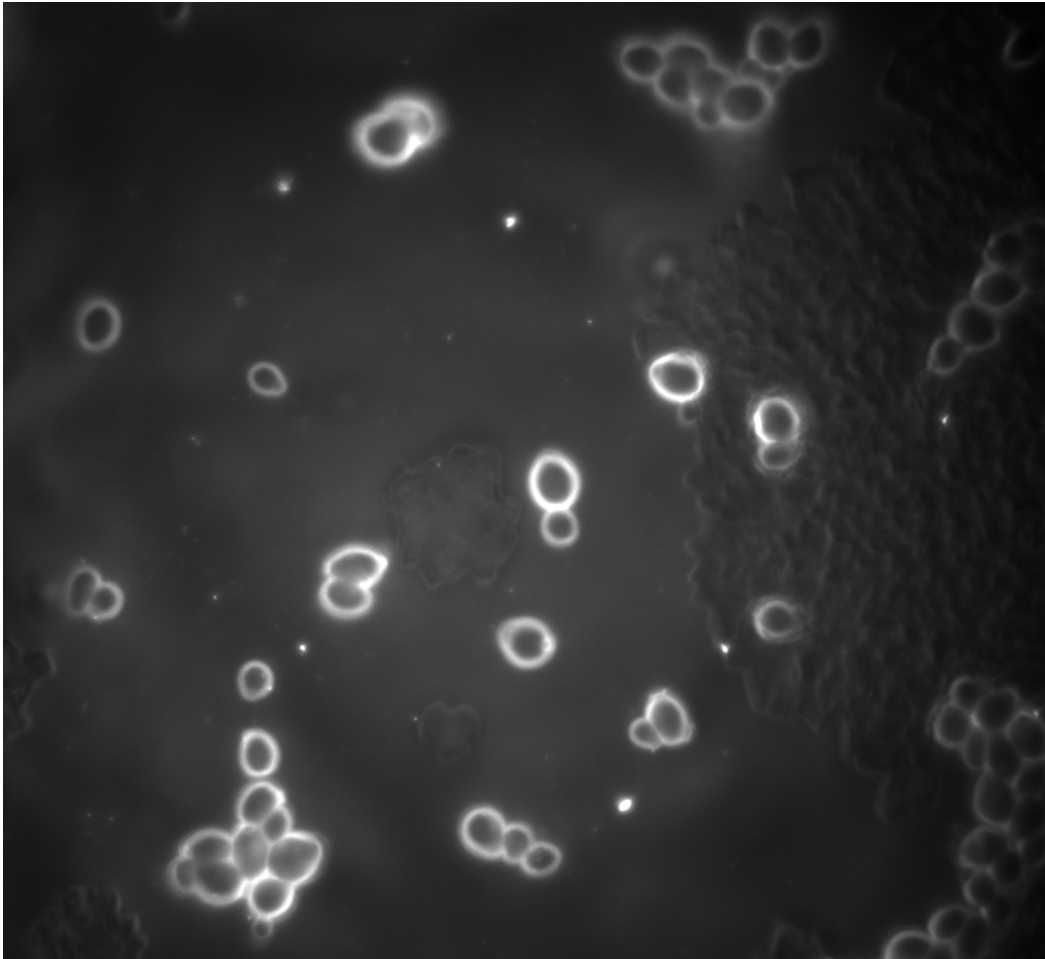

Figure 3. Yeast cells of the bioreactor budding and forming daughter cells.  
Courtesy of the artist. Photo © Philippe Parreno.

If, on the other hand, the temperature is lowered, the pH value becomes more and more acidic, and if the optical density and the oxygen partial pressure are too high, then the reproduction rate of the yeast cultures, which is normally exponential, is reduced.

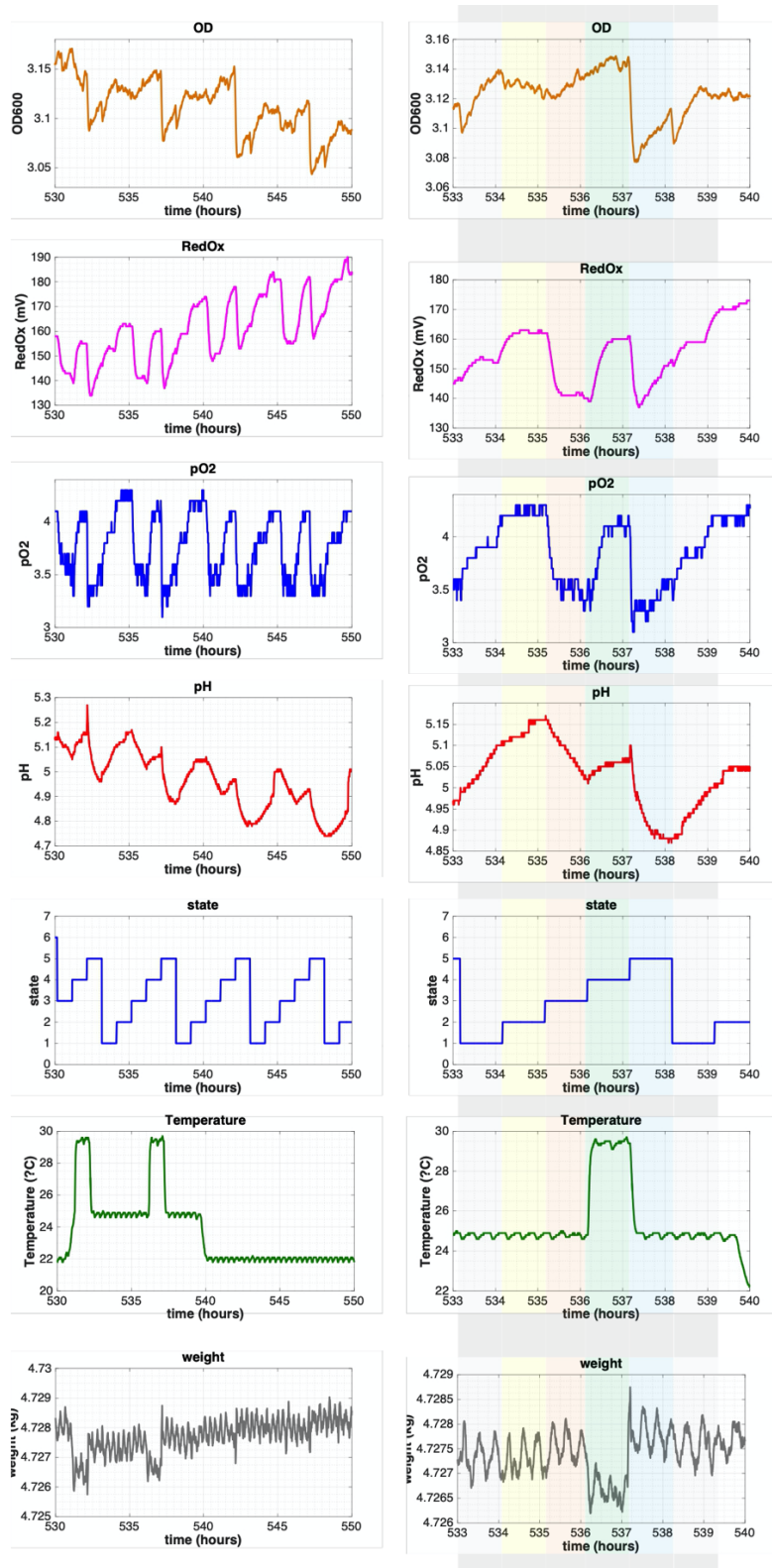

Figure 4: Recording of various parameters of the bioreactor, Tate Modern, London, 2016-2017. Time duration 20 hours (left column) and 7 hours (right column), OD600 [optical density at 600nm]; RedOx [reduction potential]; pO2 [oxygen partial pressure]; pH value; temperature. Photo © Philippe Parreno

The correlation of the system behaviour with the timing of targeted nutrient additions and manipulations of the temperature can be observed in the diagram. The left column shows a time lapse of 20 hours (hours 530-550) and the right column a detailed action sequence of 7 hours (hours 533-540). For example, it can be seen from the temperature curve that the temperature was raised twice from 25° to 30° and lowered once to 22°. <sup>29</sup>

Within the exhibition, the bioreactor assumes the function of an autopoietic system that generates its decisions or actions from its own internal states, i.e. from its own behaviour. This mode of operation is completely dissimilar to the electronic network computer at MoMA, which bases its decisions on a random algorithm. Now the environment no longer provides data for the behaviour of the exhibited objects. The bioreactor's own behaviour provides the sensory information that is used to control the exhibition. Parreno says:

The only way for us to communicate with the yeast was to deprive them from sugar or feed them with sugar, to deprive them from oxygen or to dilute them with water. We had a couple of small and tiny little things that we could do to force them to do things and that was according to the events that were sent by the machine around that was in fact given to the bioreactor and that the bioreactor would send back a signal to us. ... this is what happened. The yeast was digested and the signal was sent back to us. <sup>30</sup>

The bioreactor is a sympoetic machine within the scripted exhibition space. The sensory data no longer come from the outside, but from within. They are generated by the bioreactor's own behaviour. While in New York the behaviour of the multimedia installation depended on external environmental data, in Berlin the behaviour of the exhibition was dependent on the eigenbehaviour of the biological input output system.

Another difference comes into play. While weather data is contingent, i.e. always possible in a different way, the bioreactor can be specifically stimulated or throttled by external influence. By adding or withdrawing nutrients or by changing the framework conditions such as temperature, pH value or oxygen partial pressure, deliberate stress can be exerted on the yeast cultures. This leads to an altered state and in consequence of this to a change in the exhibition choreography. The motor control of the exhibition by environmental events is replaced by a deliberate stimulation of living organisms.



The sensorimotor system of the bioreactor is a visible part of the exhibition choreography. It is openly staged and displayed like a scientific apparatus in a technical museum. The bioreactor controls the behaviour of individual objects in the exhibition. Lamps are switched on and off or made to flicker with the help of the DMX protocol. The blinds of nine windows (*Nine Blind Sisters*, 2018) move up and down at different speed, music is suddenly played from a Yamaha disklavier and stopped again. A chrome-plated shutter opens its mirrored slats, closes them again or leaves them in a partially open state. A Marquee begins to play an abstract sequence of light bulbs turning on and off, as if communicating in a language unknown to us. The black water surface of *Sonic Waterlilies*, 2018 is seemingly set into concentric motion by an invisible hand, as if it begins to rain or water fleas scurry across the surface. A round seating landscape covered in black felt and made of triangular elements of different heights (*Bleachers*, 2018) slowly sets itself into spinning motion (Figure 5).



Figure 5: Exhibition view, Philippe Parreno, Gropius Bau, Berlin, 2018.  
Top: *With a Rhythmic Instinction to be Able to Travel Beyond Existing Forces of Life*, 2018; LED panels, MacMini, speakers, amplifier, powder-coated steel, 2 parts each: 350 x 200 x 100 cm. Below: *Bleachers*, 2018; MDF panels, foam, cotton, motor 90 cm x ø 700 cm Courtesy of the artist; Pilar Corrias, London; Gladstone Gallery, New York; Esther Schipper, Berlin.  
Photo © Andrea Rossetti

## Exhibitions as Medium and Form

The artist does not consider his work as a collection of individual artworks that he arranges chronologically or thematically, but rather as a medium in which forms can emerge temporarily, but also disappear again. The units of an exhibition exist in different modal states: latent-overt, potential-actual, present-absent. Parreno himself speaks in this context of *scripted spaces*, a term he borrows from the book *The Vatican to Vegas. A History of Special Effects* by Norman M. Klein.

By scripted spaces, I mean primarily a *mode of perception*, a way of seeing. ... Scripted spaces are a walk-through or click-through environment (a mall, a church, a casino, a theme park, a computer game). They are designed to *emphasize* a viewer's journey — the space between — rather than the gimmicks on the wall. The audience walks *into* the story. What's more, this walk should respond to each viewer's whims, even so each step along the way is prescribed (or should I say preordained?). It is gentle repression posing as free will.<sup>31</sup>

This means a fundamental shift in the understanding of exhibition making from a more or less static and contingent addition of individual objects to a dynamic and holistic approach. Parreno's work thus intervenes in a very innovative way into the history of exhibition display. As a medium, an exhibition exists in the form of potentiality. Only through a specific arrangement, assembly or display of objects does an exhibition space emerge as a specific form with a limited duration.<sup>32</sup> The exhibition appears in its actuality. As a medium, the objects exist only in their potentiality. They are *loosely coupled*.<sup>33</sup> They are potentially connectable and disconnectable.

In the form in which they become visible in an exhibition, in a specific city, a specific institution and for a specific period of time, they are *tightly coupled* to each other both spatially and temporally for the duration of the exhibition.<sup>34</sup> The interactions between the objects exist precisely for this period and for this place. Afterwards, they are uncoupled again, dissolved into their individual parts, put into storage, disposed of or recycled.<sup>35</sup> In their stored form, exhibitions are a medium. If the objects are on show, they are a specific form in which the interactions between space, time and visitors have a strictly coupled, temporary duration.

The form of an exhibition scripted by Philippe Parreno therefore has two sides, namely an *inside* that can be perceived with all senses and a latent, unobservable *outside*. On the inside of the exhibition, various forms, objects or events emerge or pass away. The whole exhibition can be understood as an aesthetic situation, spatially as well as temporally and socially.<sup>36</sup> The exhibition units are transformed into a spatial, temporary and social mode of existence that can always be re-

assembled and re-dissolved anew.<sup>37</sup> The concept of the exhibition as medium or form is intrinsically coupled with the temporalisation of the art work. Many of Philipp Parreno's works therefore do not exist forever. They only exist in the mode of actuality when a certain combination of sensory input, algorithmic or biological processing and digital or analogue motor output brings the work into presence - from potentiality to actuality, from the mode of possibility to the mode of appearance.<sup>38</sup>

## Conclusion

Perception is not a passive reception of stimuli or sensory data, but a complex translation process that takes place at the boundary between the surrounding medium and the closed surfaces of the sensory organs. Furthermore, perception is always multisensory. All senses are always active at the same time. The neuronal activity patterns converging from individual sensory channels are integrated in different brain areas to form a unified experience of space and time. A visit to an exhibition takes place with all senses. Aesthetic experience is enactive, embodied and embedded. In a traditional aesthetic experience, the neural activity patterns from a particular sensory channel, such as the sense of sight or the sense of hearing, take precedence over the other senses in multisensory integration. They possess greater relevance in aesthetic judgement. In an exhibition designed by Philippe Parreno, all of the visitor's sensory channels are simultaneously involved in the aesthetic experience. The exhibition itself is an aesthetic hyperobject, which a visitor must produce himself through his enactive perceptual action. Parreno choreographs the aesthetic experience either through multimodal sensory inputs, originating from the environment and processed with the help of algorithms or artificial intelligence, or from the intrinsic behaviour of a bioreactor, which performs a non-periodic, non-repetitive control of the individual exhibition units. In this way, the exhibition itself becomes a sympoietic form that switches back and forth between potentiality and actuality, between presence and absence in an unpredictable way, thereby generating a unique, non-repeatable, multimodal, aesthetic experience.

## Author Biography

**Hans Dieter Huber**, lives in Berlin. Artist, filmmaker, curator, scientist. He studied painting and graphic arts, as well as art history, philosophy and psychology. From 1997 to 1999 Professor HGB Leipzig; from 1999 to 2019 Professor of Contemporary Art History, Aesthetics and Art Theory at the State Academy of Fine Arts Stuttgart. 2007 Senior Fellow at the International Research Centre for Cultural Studies in Vienna. From May 2006 to October 2011 Head of the International Master's Programme "Conservation of New Media and Digital Information" at the State Academy of Fine Arts Stuttgart. From 2006-2009 Professor at the DFG Post Graduate Program "Image, Body, Medium", HfG Karlsruhe. 2009-2015 Member of the scientific board of Society for Interdisciplinary Image Science (GIB) Bildwissenschaft. Since 2013 member of the Scientific Advisory Board of the International Institute for Subjective Experience and Research (ISER) at the MSH Medical School Hamburg. From December 2016 to June 2021 Deputy Chairman of the Württembergischer Kunstverein Stuttgart. From 2017 - 2020 Member of the Board of Trustees of the Adolf Hölzel Foundation, Stuttgart. info@hdhuber.net, www.hdhuber.net  
ORCID: 0000-0001-9113-8141

## Notes

1. Huber 2018a; Huber 2018b; Huber 2021a; Huber, and Parreno 2021b; Huber, and Parreno 2021c; Huber 2023.
2. The term "scripted space" was coined by Klein 2004. See for further details footnote 31 of this text.
3. The term "hyperobject" stems from Morton, 2010. It was suggested to Philippe Parreno by Hans Ulrich Obrist in an interview in Obrist, and Parreno, 2017, 119. For a definition of the term see The term hyperobject comes from Morton, Timothy, *The Ecological Thought* (Cambridge, Massachusetts: Harvard University Press, 2010). It was suggested to Philippe Parreno by Hans Ulrich Obrist in an interview in Obrist, Hans Ulrich, and Parreno, Philippe, "Beyond Ideas." in Philippe Parreno. *H (N)Y P N(Y) OSIS HYPOTHESIS*. Exhibition catalogue Park Avenue Armory, New York, 11.06.-02.08.2015, Pirelli HangarBicocca, Milan, 22.10.2015-14.02.2016. (Milan: Mousse Publishing, 2017), 119. For a definition of the term see Morton 2013, 1f:  
"... I coined the term hyperobjects to refer to things that are massively distributed in time and space relative to humans. A hyperobject could be a black hole. A hyperobject could be the Lago Agrio oil field in Ecuador, or the Florida Everglades. A hyperobject could be the biosphere, or the Solar System. A hyperobject could be the sum total of all the nuclear materials on earth; or just the plutonium, or the uranium. A hyperobject could be the very long-lasting product of direct human manufacture, such as Styrofoam or plastic bags, or the sum of all the whirring machinery of capitalism. Hyperobjects, then, are >hyper< in relation to some other entity, whether they are directly manufactured by humans or not. Hyperobjects have numerous properties in common. They are viscous, which means that they >stick< to beings that are involved with them. They are nonlocal; in other words, any 'local manifestation' of a hyperobject is not directly the hyperobject. They involve profoundly different temporalities that the human-scale ones we are used to. ... And they exhibit their effects interobjectively; that is, they can be detected in a space that consists of interrelationships between aesthetic properties of objects." One cannot escape the feeling that Morton means systems when he speaks of hyperobjects.

4. Huber and Parreno 2021c, 8.
5. Sartre 1957, xlvii.
6. On the notion of operational closure, see Varela and Goguen 1976; Maturana 1982, 282-284; Luhmann 1995a, 12-24; Luhmann 1995b, 13.
7. For an introduction to the term, see Baraldi, and Corsi, and Esposito 1998, 186-189 or Jahraus, and Nassehi 2012, 121-123.
8. See Gibson 1979, 127: "The *affordances* of the environment are what it *offers* the animal, what it *provides* or *furnishes*, either for good or ill. ...I mean by it something that refers to both the environment and the animal in a way that no existing term does. It implies the complementarity of the animal and the environment."  
See further Huber 2021b, 135-157.
9. Noë, and O'Regan, 2002, 567-598..
10. This is a reference to the title of a famous book. See Goodman 1978..
11. On the concept of range, see Schütz, and Luckmann 1979, 64.
12. Cf. in more detail Schumacher 2000, 94-103; Huber 2009, 97-103; Umathum 2011; Divjak 2012.
13. Stein, 2012, XI.
14. Stein, 2012, XIII.
15. Schroeder 2012, 97.
16. Spence 2012, 243.
17. Parreno, 2014; Lissoni 2016; Parreno 2017a; Parreno 2017b; Oberender, and Rosenberg 2018.
18. For illustrations of this work see the text by Keny, and Reed, and Girma, 2020.  
<https://www.moma.org/magazine/articles/378>
19. Ovidius, 1922, Book III, 356-358.
20. "DMX512 is a standard for digital communication networks that are commonly used to control lighting and effects. It was originally intended as a standardized method for controlling stage lighting dimmers, ... DMX512 has also expanded to uses in non-theatrical interior and architectural lighting, at scales ranging from strings of Christmas lights to electronic billboards and stadium or arena concerts. It can now be used to control almost anything, reflecting its popularity in all types of venues."  
<https://en.wikipedia.org/wiki/DMX512>; 22.2.2022.
21. Keny/Reed/Girma 2020: "... all these things come together and feed the machine that then responds randomly." [without page]
22. Roads 2001, 86.
23. Roads 2001, 85-118; Reck Miranda 2006, 101-111.
24. <https://bronze.ai>.
25. An internet version of this work can be seen and heard via the WWW by typing in the URL *echo.world*. 3D glasses would be helpful as this is a 3D space. The moving image that one perceives is, according to the artist, a 3D visualisation of Artificial Intelligence.
26. Huber, and Parreno 2021a, 2: "That's a visualization of the AI, projecting a sort of space, the space of the automaton."

27. The bioreactor was developed in collaboration with Jean-Baptiste Boulé of the CNRS Centre national de la recherche scientifique and Nicolas Desprat, Institut de Biologie de l'Ecole Normale Supérieure, and two other scientists from London. See Parreno 2018, p.70. In 2016, it was used for the first time in his solo exhibition IF THIS THEN ELSE at Gladstone Gallery, New York, then in the exhibition "Anywhen" at Tate Modern, London, and in 2017 in the exhibition "La Levadura y el Anfitrión" at Museo Jumex, Mexico City.
28. As far as I know, Philippe Parreno used the notion of a sympoietic machine for the first time in my conversation with him from January 28, 2021. On the concept of sympoiesis see Dempster 1998; Dempster 2000; Haraway 2016.
29. I owe my understanding of how the bioreactor works to a detailed conversation with Dr Harald Sobek, Biberach an der Riss, a biologist and biotechnologist. I would like to take this opportunity to thank him most sincerely.
30. Huber, and Parreno 2021c, 6.
31. Klein 2004, 12 and 20.
32. Luhmann 1997, 198.
33. See further Glassman 1973, 83–98; Weick 1976, 1–19; Luhmann 1993, 223; Luhmann 1997, 195–202.
34. Luhmann 1997, 200.
35. Luhmann 1997, 199.
36. See in more detail Huber 2019 and Huber 2020.
37. Luhmann 1997, 201.
38. Goodman 1977.

## Bibliography

- Baraldi, Claudio, and Corsi, Giancarlo, and Esposito, Elena. *GLU. Glossar zu Niklas Luhmanns Theorie sozialer Systeme*. Frankfurt am Main: Suhrkamp, 1998.
- Dempster, Beth M. "A Self-Organizing Systems Perspective on Planning for Sustainability." Master diss., University of Waterloo, Ontario, Canada, 1998.  
<https://citeseerx.ist.psu.edu/viewdoc/download?doi=10.1.1.180.6090&rep=rep1&type=pdf>
- . "Sympoietic and autopoietic systems: A new distinction for self-organizing systems." In *Proceedings of the World Congress of the Systems Sciences and ISSS 2000* edited by J.K Allen and J. Wilby. Presented at the International Society for Systems Studies, Annual Conference, Toronto, Canada, July 2000.  
<https://citeseerx.ist.psu.edu/viewdoc/download?doi=10.1.1.621.9187&rep=rep1&type=pdf>
- Divjak, Raul. *Integrative Inszenierungen. Zur Szenografie von inszenierten Räumen*. Bielefeld: transcript, 2012.
- Gibson, James J. *The ecological approach to visual perception*. Boston, Mass.: Houghton Mifflin Company, 1979.
- Glassman, R. B. "Persistence and Loose Coupling in Living Systems." In: *Behavioral Science*, Vol. 18 (1973): 83–98.
- Goodman, Nelson. *The Structure of Appearance*. 3rd edition. Dordrecht-Holland, Boston -U.S.A.: D. Reidel Publishing Company, 1977.
- . *Ways of Worldmaking*. Hassock, Sussex: The Harvester Press, 1978.
- Haraway, Donna. *Staying with the trouble: making kin in the Chthulucene*. Durham; London: Duke University Press, 2016.
- Huber, Hans Dieter. "Uncanny Lessons. Aesthetic Conditions in the Work of Markus Schinwald." In *Markus Schinwald. Vanishing Lessons*. Exhibition catalogue Kunsthaus Bregenz 14. Februar – 13. April 2009. Köln: Buchhandlung Walther König (2009): 97 – 103.
- . "Multisensorisches Wissen." In *IMAGE. Zeitschrift für interdisziplinäre Bildwissenschaft*. Heft 28, (July 2018a): 107-112.  
<http://www.gib.uni-tuebingen.de/own/journal/pdf/IMAGE%2028.pdf>
- . "Welterzeugung durch sensomotorisches Handeln." In *Intermedialität und Performativität in den künstlerischen Therapien*, edited by Peter Sinapius, 90-119. Berlin: epubli, 2018b.
- . "Towards a Theory of the Aesthetic Situation." In *Art Style, Art & Culture International Magazine*, vol. 3, no. 3 (September 2019): 27-36.  
<https://doi.org/10.5281/zenodo.4116509>
- . "Ästhetik der Situation." In *Situationen. Theorien der Situation und künstlerische Praxis*, edited by Petra Maria Meyer, 98-112. Paderborn: Wilhelm Fink Verlag 2020.
- . "Materiality, Embodiment and Affordance in Paul Graham's, a shimmer of possibility." In *Art Style, Art & Culture International Magazine*, Vol. 4, no. 7 (March 2021a): 135-157. <https://doi.org/10.5281/zenodo.6371518>
- , and Parreno, Philippe. "Philippe Parreno. Das Echo der Maschinen. Ein Interview von Hans Dieter Huber." In *"Kann KI Kunst? AI ART: Neue Positionen, technisierte Ästhetiken von Mensch und Maschine"*, edited by Pamela Scorzin. *Kunstforum International*, vol. 278 (Nov.-Dez. 2021b): 152-161.
- , and Philippe Parreno. *Feed and Deprive. Interview with Philippe Parreno*. Do, 28. (Januar 2021c). Unpublished manuscript, 1-8.
- . "Feed and Deprive. Künstliche Intelligenz und biologische Steuerungssysteme im Werk von Philippe Parreno." In *Theorie und Praxis der Maschinenkünste im 20. und 21. Jahrhundert Prozesse – Medien – Kreativität*, edited by Claudia Mareis and Michael Rottmann. Basel: Hochschule für Gestaltung und Kunst FHNW Basel, 2023 (forthcoming)



- Jahraus, Oliver, and Nassehi, Armin, eds. *Luhmann-Handbuch. Leben – Werk – Wirkung*, 121-123. Stuttgart: Metzler, 2012.
- Keny, Tara, Peter Reed, and Girma, Hanna. "Dreams of a Machine. Philippe Parreno discusses his work 'Echo Radio', a 2020 addition to his commission *Echo*, which was created for MoMA's 2019 reopening." July 14, 2020.  
<https://www.moma.org/magazine/articles/378>
- Klein, Norman M. *The Vatican to Vegas. A History of Special Effects*. New York, London: The New Press, 2004.
- Lissoni, Andrea, ed. Philippe Parreno. *Anywhen*. Exhibition catalogue Tate Modern, London 4. Oct. 2016-2. April 2017. London: Tate Publishing 2016.
- Luhmann, Niklas. "Die Evolution des Kunstsystems." In *Kunstforum International*, vol.124 (November - December 1993), 221–228.
- . "Probleme mit operativer Schließung." In *Soziologische Aufklärung*. Vol. 6. *Die Soziologie und der Mensch*, edited by Niklas Luhmann, 12 – 24. Opladen: Westdeutscher Verlag, 1995a.
- . *Die Kunst der Gesellschaft*. Frankfurt am Main: Suhrkamp, 1995b.
- . *Die Gesellschaft der Gesellschaft*. Frankfurt am Main: Suhrkamp, 1997.
- Maturana, Humberto R. *Erkennen. Die Organisation und Verkörperung von Wirklichkeit*. Braunschweig/Wiesbaden: Friedr. Vieweg & Sohn, 1982.
- Morton, Timothy. *The Ecological Thought*. Cambridge, Massachusetts: Harvard University Press, 2010.
- . *Hyperobjects. Philosophy and Ecology After the End of the World*. Minneapolis, London: University of Minnesota Press, 2013.
- Noë, Alva, and O'Regan, Kevin. "On the Brain-Basis of Visual Consciousness: A Sensorimotor Account." In *Vision and Mind. Selected Readings in the Philosophy of Perception*, edited by Alva Noë and Evan Thompson, 567-598. Cambridge, Mass., London: MIT Press, 2002.
- Oberender, Thomas, and Rosenberg, Angela (Eds.). *Philippe Parreno. Gropius Bau Sommer 2018*. Exhibition catalogue Berlin, Gropius Bau 25.5.-5.8.2018. Cologne: Verlag der Buchhandlung Walther König 2018.
- Obrist, Hans Ulrich, and Parreno, Philippe. "Beyond Ideas." In *Philippe Parreno. H {N}Y P N{Y} OSIS HYPOTHESIS*. Exhibition catalogue Park Avenue Armory, New York, 11.06.–02.08.2015, Pirelli HangarBicocca, Milan, 22.10.2015–14.02.2016. Milan: Mousse Publishing (2017): 119–136.
- Ovidius, Publius Naso. *Metamorphoses*. Edited by Brookes More. Boston. Cornhill Publishing Co., 1922.  
<https://www.perseus.tufts.edu/hopper/text?doc=Perseus%3Atext%3A1999.02.0028%3Abook%3D3%3Acard%3D337>
- Parreno, Philippe. *Anywhere, Anywhere Out of the World*. Exhibition catalogue Palais de Tokyo, Paris 23. Oct. 2013-12. Jan. 2014. Cologne: Verlag der Buchhandlung Walther König, 2014.
- . *A Time Coloured Space*, Exhibition catalogue Museu Serralves, Porto, 3. Feb.- 7. May 2017a.
- . *H {N}Y P N{Y} OSIS HYPOTHESIS*. Exhibition catalogue Park Avenue Armory, New York, 11.06.–02.08.2015, Pirelli HangarBicocca, Milan, 22.10.2015–14.02.2016. Milan: Mousse Publishing, 2017b.
- Reck Miranda, E. *Computer Sound Design. Synthesis techniques and programming*. Second edition. Amsterdam [u.a.]: Focal Press, 2006.
- Roads, Curtis. *Microsound*. Cambridge, Mass./ London: The MIT Press, 2001.
- Sartre, Jean-Paul. *Being and nothingness. An essay on phenomenological ontology*. Translated and introduction by Hazel E. Barnes. London: Methuen, 1957.

- Schroeder, Charles E. "Large Questions about Multisensory Processing." In *The New Handbook of Multisensory Processes*, edited by Barry Stein, 97-102. Cambridge, Mass., London: The MIT Press 2012.
- Schumacher, Eckhard. "Passepartout. Zu Performativität, Performance, Präsenz." In *Texte zur Kunst*, Vol. 37 (March 2000): 94-103.
- Schütz, Alfred, and Luckmann, Thomas. *Strukturen der Lebenswelt*. Vol 1. Frankfurt am Main: Suhrkamp, 1979.
- Spence, Charles. "Multisensory Perception, Cognition und Behavior: Evaluating the Factors Modulating Multisensory Integration." In *The New Handbook of Multisensory Processes*. Edited by Barry Stein, 241- 264. Cambridge, Mass., London: The MIT Press, 2012.
- Stein, Barry E. "Introduction." In *The New Handbook of Multisensory Processes*. Edited by Barry Stein, XI-XVI. Cambridge, Mass., London: The MIT Press, 2012.
- Umatham, Sandra. *Kunst als Aufführungserfahrung*. Bielefeld: transcript, 2011.
- Varela, Francisco J., and Goguen, Joseph. "The arithmetic of closure." In *Progress in Cybernetics and Systems Research*. Edited by Robert Trappl and L. Ricciardi, Vol. III, Washington, D.C. (1976): 48 – 64.
- Weick, K.E. "Educational Organization as Loosely Coupled Systems." In *Administrative Science Quarterly*, Vol. 21, no. 1 (March 1976): 1–19.



# The Performing Human Being in a Media Interaction Space

Multi- and intermodal productions by the Düsseldorf  
Theater der Klänge (Theatre of Sounds)

Jörg U. Lensing

## Abstract

In the course of 35 years of work, the Düsseldorf Theater der Klänge (Germany) has dedicated itself to multimodal and, above all, intermodal manifestations of “form, movement, sound and light design as dynamic concentrations of action” as the Bauhaus master Laszlo Moholy-Nagy demanded in 1925 for a theatre of the future, in a total of nine intermedial productions. Such a theatre is not subject to the primacy of a particular genre, as is traditionally standard as dance, music or drama theatre—especially in German theatre—but rather uses the possibilities of presentation of theatre and song text, music, dance, scenography, video art, light design and possibly even further sensory stimulation to arrive at a holistic stage action in differently defined spectacle spaces. In the following scientifically oriented article, the artistic director of the Theater der Klänge, Prof. J.U. Lensing, shows how and why this ensemble was founded in 1987 on the basis of a Bauhaus stage postulate or a Bauhaus book publication. It also describes why the first two productions of this ensemble were based on Bauhaus stage ideas of the 1920s and what this has to do with the Folkwang University in Essen. Finally, starting from the reflection on the multimodality of these productions, the article describes the further systematically laid out course to intermodal stage approaches, in which the entire stage was also equipped with sensors as an interface for electronic reactions related to music and video scenography. The article’s main topic is which approaches to sensorised stages was pursued, which were discarded as rather unsuitable, and which were further developed. Finally, the question arises about the meaning of such action and the status and definition of performers in such a stage form.

## Introduction

The founding of the Düsseldorf Theater der Klänge emerged in 1987 from the so-called Folkwang idea, since almost all of the founding members at that time were recent graduates of the then still so called Folkwang Hochschule<sup>1</sup> (more conservatory of music than university) in Essen (Germany). In contrast to other ensemble foundings from this university, which were always clearly assigned to a specific genre (music ensembles, dance companies or theatre), the idea for a “theatre of sounds” was the interdisciplinary collaboration of dancers, musicians and actors, but also and above all choreographers, directors and composers. In fact, the visual arts played a subordinate role at the time of its founding, which can be explained by the range of studies offered by the Folkwang Hochschule at the beginning of the 1980s<sup>2</sup>. At that time, the university defined itself as a university for music, theatre and dance.

But even the selection of the first two materials for a first stage production involved the visual arts in the form of dance figurines and moving scenography. The actual visual-artistic designs for this were borrowed from ideas developed at the Bauhaus in Weimar in the 1920s (by the students Schmidt, Bogler and Teltscher and the Bauhaus master Laszlo Moholy-Nagy) and published in the book *Die Bühne am Bauhaus (The stage at Bauhaus)*.<sup>3</sup> Both Bauhaus designs were based on the idea of moving three-dimensional images that were to be synchronised by music (and in Moholy-Nagy’s case also by sounds) and brought into a temporally structured stage action. In a later essay, Kurt Schmidt spoke of a “stage organisation with simple forms.”<sup>4</sup> Moholy-Nagy wrote about his *Mechanical Eccentricity*: “Form, movement, sound and light design of a dynamic concentration of action will be ‘the mechanical eccentricity.’” Both approaches united multimodal possibilities of “polyphony” for the receptors eye and ear and thus a holistic approach in which traditional customs of music to dance or setting dramaturgical sequences to music played only a subordinate role. This was precisely the core of the founding impulse for an interdisciplinary ensemble whose name Theater der Klänge contains two decisive clues: *Theatre* as a collective term focusing on stage spaces for actions limited in time in a defined space in which a watching and listening audience gathers at specific times to witness an action concentration of moving images, objects, colours, human silhouettes (deformed to the point of abstraction), music, sounds and speech and/or singing. *Sounds* as the plural of sonorities that result from at least two, but more likely from a multitude of combined individual timbres to be composed.

Thought of further as audio-visual timbre composition, if one understands the audible and the visible frequency spectrum only as different frequency bands to be organised, for which people have two different receptors available (eyes and ears). Thus, multimodality and inter-modality were established, postulated and programmed from the outset, both for composition and for reception. It is said that the formulation of the Folkwang idea goes back to Karl-Ernst Osthaus,<sup>5</sup> a German patron of the arts and art educator until 1921: "Folkwang is the unity of all arts and all artistic education." He explicitly encouraged Walter Gropius, an architect he knew, to apply for the directorship of the Kunsthochschule and Kunstgewerbeschule in Weimar and promoted this application, which later led to the founding of the Bauhaus in Weimar, uniting the two schools. In Gropius programmatic speech called "art and technology a new unity" from 1923: "The widespread view that art is luxury is the pernicious consequence of yesterday's spirit, which isolated phenomena (*l'art pour l'art*) and thus deprived them of their common life.

The new spirit of construction demands fundamentally new conditions for all creative work. The tool of yesterday's spirit is the "academy." It led to the bleeding of the entire working life—industry and craft—from the artistic person and this resulted in his complete isolation. In strong times, on the other hand, the entire creative work life of the people was fertilised by the artistic man, because he stood in the midst of it, because he had acquired the same basis of work-related skill and knowledge in labourer practice, like every other workman of the people, from the bottom up, because the fatal and presumptuous error was not bred by the state that being an artist is a learnable profession. Art cannot be learned! Whether a creative work is done merely as a skill or creatively depends on the talent of the personality. This cannot be taught and cannot be learned, but a skill of the hand and a thorough knowledge as a basic prerequisite for all creative work, for the achievement of the simple worker as well as for that of the brilliant artist, can."

## Das mechanische Ballett (The Mechanical Ballet)

But let us return to the composition of the “stage organisation with simple forms,” i.e. our realisation of the “mechanical ballet” (Figure 1): The total of five figurines, all of which consist of individual parts made in the primary and secondary colours (except violet), which in turn combine straight lines with diagonals and circles, are attached to bodies and limbs of human bodies by a buckle system in such a way that they become two-dimensional puppeteers of abstract form elements through body movements, but also three-dimensional through the depth staggering of the individual elements, which nevertheless have abstracted human appearances. Kurt Schmidt and his fellow students had already named these appearances in 1923: *Windmill*, *Machine Being*, *Locomotive*, *Dancer* or *Little One*. It is striking that the figurines designed by Kurt Schmidt, based on the primary and secondary colours mentioned, have object names, while the figurines designed by Bogler and Teltscher name human appearances and are reduced to the non-colours black, white and grey in the case of the “Dancer” and to pink and white in the case of the “Little One.”

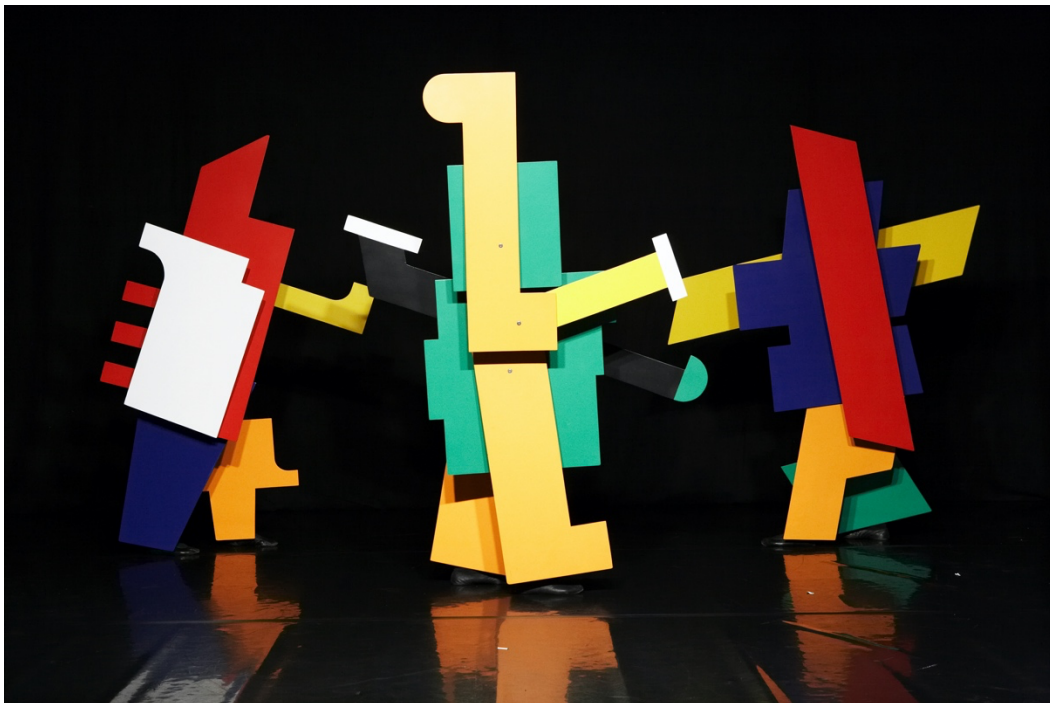

Figure 1. *The mechanical ballet: Machine Being, Locomotive, Windmill.*  
THEATER DER KLÄNGE's new adaptation of “The Mechanical Ballet” by Kurt Schmidt.  
Dancers: Laura Wissing, Kai Bettermann, Jacqueline Fischer. Photo by Oliver Eltinger, 2009.  
THEATER DER KLÄNGE's Production, Düsseldorf, 1987.

Despite the disappearance of the dancers carrying these figurine parts behind these abstract shapes, the torso, arms and legs of the figurines still remotely resemble human body shapes. This ambivalence of the perception of a semi-three-dimensionally moving abstract colour image in a stage space and an abstracting body ballet had to be confronted in the new creation of 1987. In addition, the not insignificant question arose as to whether the clattering of the figurines in movement was to be consciously made a stylistic device or whether this was to be avoided and music used instead. If so, which music and with what intention of intermodal reception?

We decided to consciously use the inherent noisiness of the figurines (in our case, plywood hitting against each other) only in exceptional situations in the sequence and thus to expose the "cardboard comrades" as a brief wink just as briefly as at the end in the second choreographed applause, in which all five dancers briefly open by turning 90 degrees to the front in order to briefly expose and thus unmask the materiality and the carrying mechanism (i.e. the illusion of the previously created two-dimensional moving images) before the image of five two-dimensional figurines is immediately restored 4 bars later. Reminiscent of the use of pianist/composer Hans-Heinz Stuckenschmidt as the pianist of the 1923 premiere and imaginary accompanying instruments as visible in photos of the so-called Bauhaus chapel, we decided on a music-live accompaniment combo of piano, trombone and percussion. Decisive for the multimodality of the interaction of sound and image, however, was the requirement that the music be created "from a perfectly fitting cast" in the course of the rehearsals by the composer-pianist Hanno Spelsberg,<sup>6</sup> who correpetited in 1987, together with the dance-improvisational and later choreographic development of this new interpretation simultaneously in all scheduled rehearsals (Figure 2). From this specification, a ballet music developed that both partially referenced 1920s jazz music and offered the "classical" functions for a dance accompaniment: rhythm, partial illustration, imitation of mechanical, machine-like sound effects, commentary, dance prelude and conclusion as well as style and genre quotations.





Figure 2. The musicians for the *Mecanical Ballet*:  
Hanno Spelsberg (Piano), Axel Heinrich (Drums), Peter Arnolds (Trombone).  
Photo by Sascha Hardt, 1988. THEATER DER KLÄNGE's Production, Düsseldorf, 1987.

## Die mechanische Exzentrik (Mechanical Eccentricity)

For the second work of this double programme, the task was much more novel. For more than 30 minutes of the 33 minutes total running time of our realisation of *Mechanical Eccentricity*, there is no human being on stage (Figure 3). Nevertheless, there is a through-composed action sequence of moving objects, for a constantly changing scenography, for a permanently changing coloured geometric light setting, and for the use of a film visible in the moving stage set and, last but not least, for an auditory experience, which on the one hand is produced directly by certain stage objects, as mediated by loudspeakers that present a mixed form of electronic music and *musique concrète*. This audio performance of fixed sounds, which is chronometrically stable in every performance, was synchronised in our realisation by two slide projectors programmed in push-pull mode, in whose magazines slides were inserted that cast geometric patterns as coloured light onto the stage. The slides had been collaged from colour filter foils using a cutting technique and were oriented in their image

geometry and colourfulness to the main layer in Moholy's graphic score. Moholy had published a catalogue of keywords for this graphic score in the aforementioned book, in which the words "clowning" and "human mechanics" also appear at the end. We interpreted these two references in such a way that, on the one hand, a mute clown figure appears, who autonomously drives mimic-body-language moving objects (3 wheels) off the stage in order to make room for the subsequently appearing dancer, who conquers the stage as a "body object" moving in itself, in order to conclude the spectacle first through "human mechanics," then increasingly through a solo dance that develops more and more smoothly.<sup>7</sup>

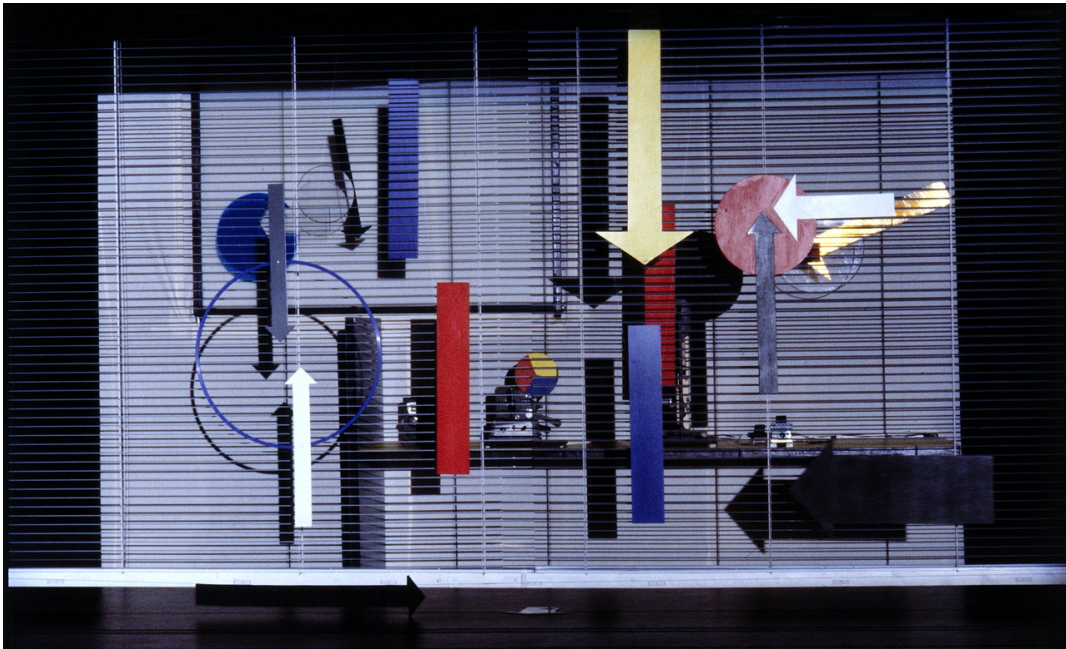

Figure 3. THEATER DER KLÄNGE's production of *The Mechanical Eccentricity* (1987) based on the (up until 1987) Moholy-Nagy's unrealised sketch. Photo by Sascha Hardt.

The multimodality here is initially limited to seeing and hearing, although rendering effects are also woven into the auditory experience, suggesting to the moving objects on the stage a noisy and sometimes rhythmic sonority that they themselves do not have. I use the term "rendu/rendering" here in the sense of Michel Chion<sup>8</sup> and translate it as "sensualisation". For example, a gold-coloured club object, which is moved into the stage space dangling on nylon threads and later divides into two halves, emits a bell-like heavy sound suggested by the loudspeaker reproduction. Through the *synchronèse*<sup>9</sup> the sonority seems to emanate from the object. Similarly, shortly before the clown figure appears, a smoking

stovepipe appears in the scenery, with a hissing sound suggested in synchronicity with the emission of smoke, which coupled with a smell we created with aroma additives, actually directly appealed to a third sense in the audience during the performance. This spectacle was about a sensual overpowering, an almost intoxicating experience which, through the combination of siren sounds with driving rhythms and an auditory, largely metallic impression of the sounds in combination with concrete sounds such as sirens, hissing, machine samples, etc., created an artificial sound space which complemented, accompanied, commented on and partly counterpointed the unleashed stage machinery on a second modal level. The *Süddeutsche Zeitung* wrote in 1989: "Technology and man are the ingredients of a magical flood of images that creates ever new tension. Finally, one emerges dazed from this maelstrom of moving images, but also richer for the experience of fantasies set wondrously in motion."<sup>10</sup>

## Figur und Klang im Raum (Figure and Sound in Space)

In 1992–93, the Theater der Klänge embarked for the first time on a project for multimodal interaction, which was to become the determining factor for a series of stage plays that from 2005 onwards led via *HOEReographien* to *SUITE intermediale* and in the wake of these two productions to *CODA*, the *Lackballett* and most recently to the fulldome production *Mensch und Kunstfigur im Kugeltheater*. But more about that later. The approach of *Figure and Sound in Space* on the level of multimodal interaction was that a computer system should be triggered by bodily actions in a stage space in such a way that light objects, light settings became visible and concrete sounds audible (Figure 4).<sup>11</sup> The stage space thus became an interface and at the same time a projection space for events that could be triggered and partly modulated by bodily actions of the performers on stage. At that time, there were only rudimentary technical solutions for such an interactively sensing and reacting stage, which is why we decided to develop, build and experiment with such instruments ourselves. Our solution at that time was six invisible cross light barriers superimposed on the stage floor, as well as a quadraphonic ultrasound system in the stage,<sup>12</sup> which could locate a microphone located in the stage by interference calculations. The light barriers were used in such a way that one could step into them and, by interrupting the respective light beam, trigger an impulse that was arbitrarily interpreted as a trigger by the

composer.<sup>13</sup> Accordingly, “stepping into” the respective light barrier triggered a sound or tone in each case, which could be heard quasi simultaneously from the loudspeakers in the theatre space. Irrespective of the latencies of this system, the performers were thus conditionally able to play a light barrier music by dancing on the stage floor in a targeted or random manner. Or to put it another way: the stage floor became a keyboard with six “keys” that could be played by the feet or bodies moving on the floor. In addition, one dancer could carry the ultrasonic microphone connected to a radio transmitter in one hand, so that body and arm movements of the leading microphone could be interpreted in the receiving GAMS-computer as graphic curves in such a way that control lines for modulations of synthetic sounds could be derived from them (amplitude and/or frequency modulations). A second computer, which could receive and interpret the trigger signals of the light barriers as well as the control data of the ultrasonic microphone, was programmed in such a way that it in turn could control six slide projectors and thus trigger slide changes, as well as a mirror system controlled by servo motors that could move certain slide light objects across a back screen controlled by dancer movement on stage.<sup>14</sup> So much for the theory and the possibilities.



Figure 4. *Figur und Klang im Raum (Figure and Sound in Space)*.  
Dancers Maria Lorrío, Kerstin Hörner and Ismini Sofou (with GAMS microphone).  
Photo by Sascha Hardt. THEATER DER KLÄNGE's Production, Düsseldorf, 1993.

The technology available in 1993, the prototype-like technical structure and the command line-oriented programming language common at the time allowed only a fraction of the above-mentioned possibilities to be implemented (Figure 5). In addition, another problem became apparent during the rehearsal and development process. Dancers are not educated and trained like musicians! While a musician usually sits and concentrates on the precise pressing, bowing, beating or striking of instruments, dancers are used to following the movement dynamics of their bodies as their biomechanics, mass inertia and centrifugal force allow and thus filling and measuring out a stage space through movement. Dynamics play just as important a role as the latency of impulsive movements, since it is always the body as a whole and not just lips, fingers or an arm that have to be set in motion, as is usual for musicians. This may result in a different way of making music if one wants to use the body as a playing instrument in a way that is appropriate for the body. This is a different approach to a different form of music than trying to create a musician analogy for dancers!

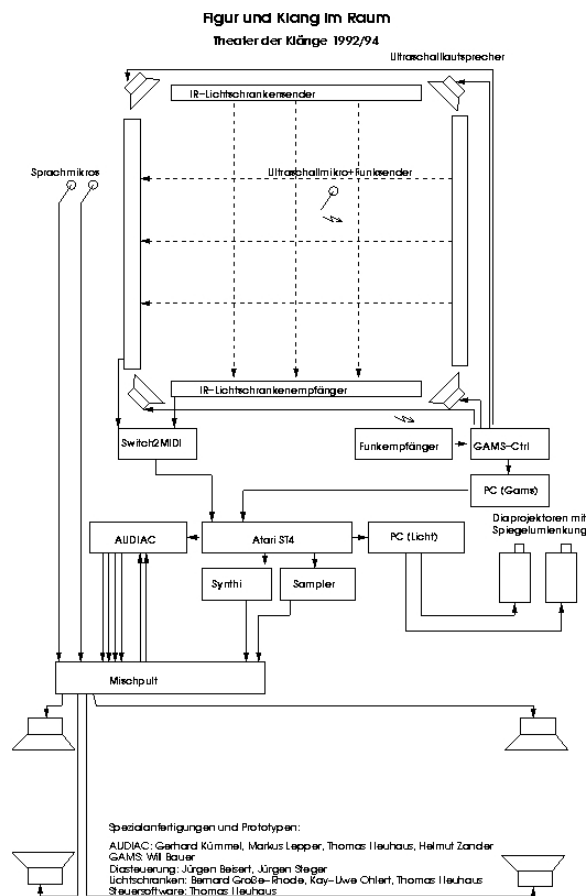

Figure 5. *Figure and Sound in Space*. The prototype-like technical structure. THEATER DER KLÄNGE's Production, Düsseldorf, 1992–94.



In 1992–93, this only became clear to us in the course of the development and rehearsal process, and with it the fact that a light barrier system reduced to lines on the stage floor and an ultrasonic microphone system specialised in arm movements and position location were not the suitable interfaces that multimodal interaction in a dance stage demanded. Nevertheless, the attempt was worth it, since in part the rigid assignments of the modal perception of sound to stage actions had for the first time really been abolished or even reversed. In the “mechanical ballet” there was always a reaction of the musicians to the dancers’ actions through the live music accompanying the performances. However, these were exhausted in improvised extensions (retardations) or shortenings of certain dance passages, depending on the dance sequences on stages of different sizes. But 95% of the music was always reproduced in the same way. The identity of the musical sequence was even stronger in the “mechanical eccentricity,” since it was completely fixed on a stereo tape and the moving objects on the stage were always in action in more or less the same way at very specific points in the audio score (Figure 6).



Figure 6. The composer and programmer Thomas Neuhaus with his Computer-Setting. Photo by Sascha Hardt, 1993. THEATER DER KLÄNGE's Production, Düsseldorf, 1993.

In *Figure and Sound in Space*, the sensors used in the stage reacted to the actions of the performers and dancers, some of which were not meticulously choreographed<sup>15</sup> but left room for improvisation and spontaneous action decisions for the performers in certain passages. In these moments, a non-timed music emerged from the physical action. The possibility of applying this to musical or even visual agogics and phrasing of the sound and light possibilities failed on the one hand because the technique was not fully developed, and on the other hand because the training effort required to turn dancers into musicians acting gesturally would have been too high. But with these experiences in tow and with a much more developed technique, this approach was taken further from 2000 onwards in such a way that it resulted in the first successful realisation of a modal interaction in the Theater der Klänge piece *HOEReographien* in 2005.

## HOEReographien (HEAReographies)

Questioning the classical dependence of dance on music was the starting point of the project *HEAReographies* (Figure 7). The modal levels were intermodally dependent on each other. Dance, i.e. body movements in a stage space, was at the same time an artefact, i.e. a performance to be seen, as well as a gestural control of musical and sound parameters. At the same time, the live filmed dancer's body was image material for an artificial deformation on a video screen in real time, which was located in the background of the stage. In certain acts of the piece, the acting dancers reacted to the video deformations, or behaved in such a way that they "painted" certain images through body movements. The cautiousness of the movements led to a different musical-dance expression than the passages of "free" and thus also impulsive dancing in other acts of the piece.

*HOEReographien* was the result of a longer research process that started in 2000 and led to the pieces *Manifest* (2000), *Megalopolis* (2001), *Modulator* (2003) and finally the research project Performer-Computer-Interaction (PCI).<sup>16</sup> At the time, PCI was financed by the FH-Dortmund (Dortmund University of Applied Sciences and Arts) and thus enabled the development of a first computer instrumentarium with which a complete interactively controlled intermedial dance concert became feasible. In a way, *HOEReographien* is the functioning completion of the approach taken with the 1993 production *Figur und Klang im Raum*.



Figure 7. *HEAReographies*. Dancer: Caitlin Smith. Video by Lucy Lungley.  
Foto by Oliver Eltinger, 2005. THEATER DER KLÄNGE's Production, Düsseldorf, 2005.

The questions of this work, which lasted several years, were:

1. To what extent can movements, lines of movement become audible in space?
2. What happens when music results from movement and what happens when musicians interact with dancers in this context?
3. What, furthermore, if the dancer's body is filmed on stage and formed into a video sculpture in real time, which in turn forms a moving whole with the human body on stage - real and virtual dance in real time?
4. If music emerges from dance movement and compositional structures are thus no longer developed, fixed and interpreted through musical compositional work, to what extent does the dancer take on compositional tasks?
5. What repercussions does this have on dance?
6. How do musical forms of variation and development manifest themselves visually in order to give a comprehensible form and structure to an initially amorphous sound result that has arisen from movement?
7. What form of light and video art as a time form results from this interactive coexistence?
8. And: How can this "new" process be made comprehensible for a live audience?



In the sensory, interactive stage of *HOEReographien* (Figure 8) no movement was without sound and image consequence, so that the action of a performer in this stage inevitably led to music and video stage image. *HOEReographien* was a cycle of individual pieces (solos, duos, trios, quartets) in the form of dance to electronic music generated by dance, dance to video sculpture developed in time and dance with live music in the form of structured improvisations, as well as mixed forms of these constellations, thus postulating an audio-visual overall composition as “autonomous” stage art in reference to the term “autonomous music.”

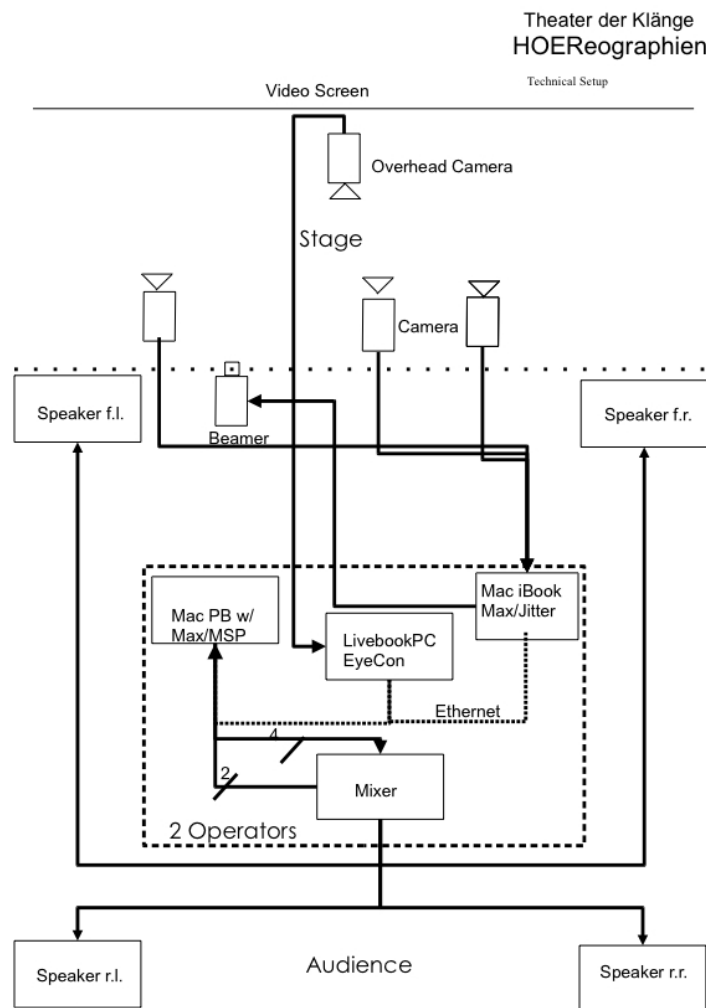

Figure 8. *HOEReographien* technical setup.  
THEATER DER KLÄNGE's Production, Düsseldorf, 2005.

Before this final result could be worked out for a public premiere in 2005, however, technical questions, questions of self-understanding in dealing with such a stage arrangement and sensible possibilities of acting with such a sensorised, media-interactive stage environment for live dancers had to be found. The 1993 approach of turning dancers into musicians, so to speak, who would play on concrete trigger points or use limbs as gestural controls for musical parameters or moving light objects was deliberately discarded, since we had hardly achieved any useful results with it in 1992–93 that would have been worth continuing. Nor did we see an aesthetically satisfying approach in filming dancers and simply reproducing these video images one-to-one on a screen in enlargements or in sections, as it was the great fashion in many dance performances, especially in the 2000s.

That's why, from 2000 onwards, we looked for a system that could implement movements in a stage space as control parameters without having to wire the dancers for this or only allowing them to act in a small space. We tested various systems that were developed, for example, for colour recognition or the precursor of the *Kinect*<sup>17</sup> for gestural control of games, but only ever came up with results that would have severely impaired the aesthetics of the stage, costumes or dance. We found a suitable system in the development of a software and hardware combination called Eyecon, which did not have these limitations and, significantly, had been developed by a programmer<sup>18</sup> in collaboration with a dance ensemble. This system made it possible to monitor the entire stage space using a camera with fish optics in such a way that even a space the size of 10m x10m at a height of 4–6m could be completely captured. After experimenting with person tracking or dividing the entire stage into differently defined fields, we decided on the Activity-Play mode that this system offered, as it corresponded most closely to dance performance and made it easiest for an untrained audience to understand the coupling of sound reactions or visual image deformations through the dynamics of movements. The acting dancers/performers enter the stage space monitored by a black and white camera. In this way, they change the pixel constellation of black and white pixels per captured video frame. Depending on how strong, how numerous these pixel changes are, the result is a rising or falling control curve, which can be used as such by a second music computer for e.g. the modulation of dynamics or pitches or also the deformation/filtering of sound spectra. Due to the low latency of the system, the sound effects are directly coupled to the increasing or decreasing physical activities of the dancer moving on stage.

For the dancers themselves, it is relatively easy to learn how to work with the sound effects of their actions, although it became apparent during the development and rehearsal processes that the handling, the creation of musical phrasing and the pauses that have to be consciously set with it required the greatest learning process, since dancers tend to move without pauses when they are asked to improvise dance. This, however, is just as contrary to the need for comprehensibility in music as the necessity to develop dance improvisation derived from music as a way of dealing with constants and variables, i.e. ultimately as a visual thematic variation technique, in order to arrive at comprehensible and meaningfully developing temporal progressions both structurally and tonally. Improvisation, on the other hand, was required because it was not a matter of developing rigid choreographie<sup>19</sup> to musical scores that always run in the same way, but rather of playing a musically reacting system in ever new and varied ways, reacting in real time to movements in a defined, sensorised and visible stage space. The same applied to the creation of abstract images on the screen, which, however, should have a clearly recognisable reference to the live filmed bodies on stage.

The cameras in *HOEReographien* were clearly visible at the front of the stage, so that it was also clear to the audience when exactly who in which costume colour was dancing into which camera, and at that very moment an abstract deformation and at times also freezing of these visualities took place on the screen. This was obviously not prefabricated and projected, but filmed live and transformed into video art in real time. Both the composer and the video designer had to cope with other tasks in this inter- and multimodal arrangement, as did the dancers, who were also musicians and video image makers, and the choreographer, who had to provide the director's scenic settings with thematically recognisable movement material in such a way that it could be used live and improvisationally on stage. In fact, these two requirements became main themes for the majority of the following dance pieces of the Theater der Klänge: Developing a thematic variation system for dance improvisations derived from musical variation techniques.<sup>20</sup> As well as the understanding of the acting dancer body/costume as a "paint brush" for painting stage-sized canvases, which increasingly determined the scenographies of the dance pieces of the Theater der Klänge.

## SUITE intermediale

*HOEReographien* was performed several times between 2005 and 2008, including demonstrations of the working method and technical set-up in contexts such as university presentations or at *Siggraph 2006* in Boston, USA. In 2009, an abridged version entitled *HOEReographien Suite* was presented at the *tanzmesse nrw*, which was the prelude to another research project at Dortmund University of Applied Sciences and Arts in 2009–10 entitled Interactive Intermedia Performance (IIP).<sup>21</sup> This research project resulted in a modernised technical setup, which, in addition to an upgrade of Eyecon, worked with the MaxMsP-Jitter software for real-time video design and MaxMsP<sup>22</sup> for live music processing on the basis of HD-image input for video design. A 10m wide projection screen provided the complete stage background, an 8m wide black molleton curtain on the right side of the stage provided the necessary background for keying the video images, which meant that a lot of thought had to be given to whether there would be black costume parts, and if so, for which body parts, as these parts, concealed in this way, could not be seen in the video implementation (Figure 9).



Figure 9. *SUITE intermediale*. Dancer: Catalina Gomez. Video by Falk Grieffenhagen  
Photo by Oliver Eltinger, 2010. THEATER DER KLÄNGE's Production, Düsseldorf, 2010.

The stage setting as a whole again reached the design size that had already been set in 1993 for *Figure and Sound in Space*<sup>23</sup> and again included body sounds and speech sounds in the setting, which had played no role in the works from 2000 to 2009 or, as in *Modulator* (2003), only a subordinate role (Figure 10). Body sounds were recorded live in the form of floor-contact microphones, so that partial foot noises on the stage floor became sound material (samples), as did rolling or otherwise acting bodies on a resonating stage floor used as a sounding board. In the last act of *SUITE intermediale* there was also a song sung live into a microphone, which became direct sound material for the deformation and modulation through movements.

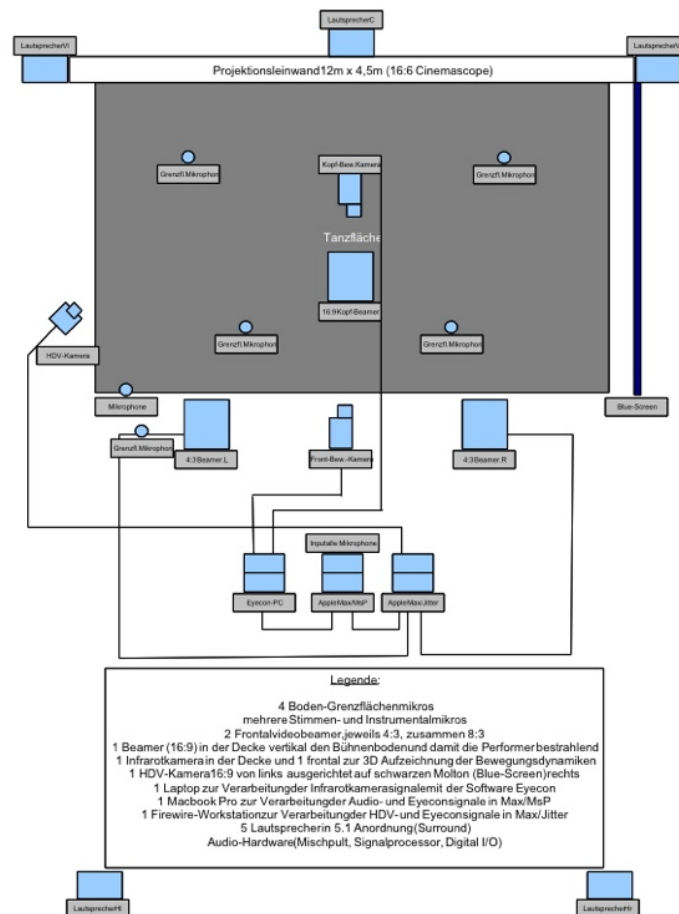

Figure 10. *SUITE intermediale*. The stage setting. THEATER DER KLÄNGE's Production, Düsseldorf, 2010.

The question of interaction plays a decisive role in such a process, since it is not about individual authorship, but about collective development in the combination of the most diverse competences. The equality of musical algorithms, video algorithms, choreographic modular material and staging units alone demands discipline and respect for the performance of those equally involved in the development process<sup>24</sup>. In addition, there is the unusually large freedom of design possibilities for the performers, since they are not only dancers, but at the same time also image providers for the video input and musicians of the sound structures offered live by the composer.

At the same time, they have to work structurally improvising within the framework agreed with the choreographer, varying the set movement material. Last but not least, they must have a precise knowledge of the technique used, similar to that of a musician who knows his instrument well and knows how to play it. The technical possibilities of live-electronic music and live-electronic video being performed by and with professional dancers does not necessarily mean that a meaningful intermedial interaction will result. A meaningful intermedial handling of the possibilities offered is an acting-reacting-taking-up-continuing and leading to a designed consequence. Only when the sum of the media and variation possibilities used becomes more than the individual components and only when one becomes senseless or no longer feasible without the other, does a genuine intermedial and thus also multi- and intermodal performance result. Whereas the classical suite is a composed sequence of music for (stage) dances, the *SUITE intermediale* was a sequence of audio-visual compositions performed by dancers. Here, approaches of *Musique Concrète* met with electronically interactive music, as well as theories of "absolute film" and "expanded cinema" with modern real-time transformation by computer in a real-time composition that took on a varied form in each performance.

In 2010, *SUITE intermediale* represented the completion of the approach of 1987 (*The Mechanical Eccentricity*) and 1993 (*Figure and Sound in Space*) and was for several years the manifestation of the Theater der Klänge for a continuation of the multimodal Bauhaus stage approach of a "design of form, movement, sound and light to a dynamic concentration of action" into the digital age. However, it was important for us not to fall prey to the fascination with mechanics, as was the case for Schmidt and Moholy in the 1920s, but also not to succumb to the fascination with the digital, as has been the case in many productions of the last 20 years.<sup>25</sup>

The focus of our interest has always been the acting human being on stage, i.e. the trained performer who, by means of his physical-musical abilities, both dances for show and acts in a physical-gestural way for the audience to hear. At the same time, his moving body, colourfully defined by selected costumes, forms the colour palette and the form material for live video art as a scenographic setting in which he in turn acts and reacts and makes decisions that not only have effects on direct physical visibility, but also sound and scenographic. This recursive looping is defined as multimodal and intermodal.

### VANITAS, CODA and Das Lackballett (the lacquer ballet)

In the Theater der Klänge productions *VANITAS - Schall und Rauch* (2012), *CODA - Bach's Cello Suite in C minor* (2013) and *Das Lackballett - Farb-Klang-Rausch* (2019), the *SUITE intermediale* setup was used as a tool for specific scenes or for other questions. *VANITAS*<sup>26</sup> is essentially a revue of the most diverse dance, acting and media-mixed scenes, as the Theater der Klänge has repeatedly used for other themes as *The Baroque Masked Stage* (1989), *November 1918\* 1989* (1991), *Jubilee* (1997), *Megalopolis* (2001) or *Oops, We're Still Playing* (2022). *CODA* (Figure 10) uses the set-up of *SUITE intermediale* both for video playback of the scenography and for projection onto bodies, and incorporates a cello<sup>27</sup> as a live instrument into the sound, incidentally dispensing with floor contact or vocal microphones as were still used in *SUITE intermediale*.



Figure 10. CODA. Tobias Rosenberger (Videooperator), Thomas Neuhaus (Composer), Beate Wolff (Cello). Foto by Oliver Eltinger, 2013. THEATER DER KLÄNGE's Production, Düsseldorf, 2013.

*The Lacquer Ballett* (Figure 11) bears the subtitle *Farb-Klang-Rausch* (Colour-Sound-Frenzy) and once again draws its original idea directly from a historical “Bauhaus” original, the ballet of the same name by Oskar Schlemmer from 1941. The former Bauhaus master designed a so-called *Lackballett* (*lacquer ballet*) as his last stage work, not publicly—since he was considered a so-called “degenerate artist” at the time. It was performed once on 6 December 1941 in Wuppertal as part of a celebration of the *Wuppertaler Farbwerke Herberts*—which employed him at the time as an artistic collaborator and instructor for lacquer experiments—and was not revived until 2019. In 2018–19, the Theater der Klänge used the anniversary of 100 years of the Bauhaus as an opportunity to deal with this *Wuppertal* work by Schlemmer and to continue the idea in a new contemporary form and perform it again 77 years later. On the one hand, the figurines designed and realised by Oskar Schlemmer were reinterpreted.<sup>28</sup> The reinterpretation was primarily a matter of material and colour interpretation, as the subject of lacquer today allows for different responses than it did in the 1940s. On the other hand, in 2018–19 both the sculptural movement possibilities and the resulting choreographies in the form of figurine dances and a final “round dance” were newly developed for an evening-long programme. The *Lackballett* was embedded in an interactive live video scenography and interactive live electronic music, as Theater der Klänge had already developed and tested since *HOEReographien*. The result was a contemporary colour and form performance, a “colour-sound intoxication” that turned the theme of lacquer paintings in combination with lacquer figurines into light paintings that constantly reshape, paint over and appear differently through physical performance and music. In the spirit of Oskar Schlemmer, this is both a contemporary art action and a dance concert!

Intermodality in this piece in relation to musical modulation played a subordinate role in comparison to *SUITE intermediale*, but also in comparison to the preceding *HEAReographies* or the follow-up piece *CODA*, while it experienced an increase for the video level. The costumes/figures designed by Schlemmer are in themselves characterised by a variety of shapes and colours that the “normal” monochrome dance costumes for the previous productions could not offer. Therefore, the costume images alone resulted in a spectrum of “brushes” for the video input, which led to much more varied video images than was comparatively the case in *SUITE intermediale*. The screen was therefore set on a large easel in the truest sense of the word as a scenographic setting, so that the video images on this screen could be understood as “lacquer pictures” that were permanently being deformed and painted over, which were painted by the dancers as



painters/brushes through dance actions. Here the levels of perception become blurred for an audience: are they witnessing a dance performance, is this live video art, is this a live electronic concert with a stage show or is the whole thing a digital art performance incorporating electronic music and dance? Here it also becomes difficult to define the action as multimodal in relation to the perceptual levels of image and sound. The intermodal approach is obvious, although it plays a subordinate role in the live perception by an audience. The actors using a stage space as an interface space by means of Eyecon, MaxMsP and MaxMsP-Jitter are not understood as such, but as interactors not dependent on a specific technique in a picture, figurine, dance, music = three-dimensional art setting in a theatre context. This approach had to be extended to an even larger space with its media setting, as the Theater der Klänge did in 2021 with its production *Mensch und Kunstfigur im Kugeltheater (Man and Art Figure in a Spherical Theatre)* in the context of a full-dome space with spatial audio.



Figure 11. *The Lacquer Ballet*. Dancer: Tuan Ly. Video by Yoann Trelu.  
Photo by Oliver Eltinger, 2019. THEATER DER KLÄNGE's Production, Düsseldorf, 2019.

## Mensch und Kunstfigur im Kugeltheater (Man and Art Figure in a Spherical Theatre)

With a large 180-degree projection dome and a spatial audio room with 64 speakers, the Planetarium Bochum (Germany) currently offers a technical infrastructure that is not available in conventional theatres or cinemas in this size and quality. At the same time, such spaces are only suitable to a limited extent for live art in the form of concerts or theatre and dance performances, as they simply do not have the stage and lighting requirements that theatres offer.

Based on a utopian design by Bauhaus student Andor Weininger for a spherical theatre from 1927, we took up this idea and planned a stage setting for the cooperating Planetarium Bochum that combined a minimally large chamber stage measuring 6m x 4m with an oval stage running around the *Universarium* (the light-star projector) as an action area. The limited lighting possibilities were supplemented by mobile tripods and LED spotlights in such a way that they ensured sufficiently dimmable theatre lighting. The cameras used for the video feeds and the Eyecon input for parameter control of sound and video were, unlike in previous productions, placed frontally on a tripod so that the angle of view of the cameras corresponded to that of the audience. In contrast to the purely interactive previous productions (see above), individual intermediate acts were created, which used existing visual and musical material to insert independent audio-visual intermezzi into the live acts as separators. The graphic visual material and partly also verbal off-commentaries for these interludes were derived from the books *Der Mensch*<sup>29</sup> and *Briefe und Tagebücher*<sup>30</sup> by Oskar Schlemmer. His reflection on the difference between human forms of representation (nude, body mechanics) and art figures derived from corporeality (figurines) was the reflective content of the piece *Mensch und Kunstfigur im Kugeltheater* (Figure 12).

In the 1920s, artists imagined new theatre spaces in which new forms of theatre would be seen in the future that would have little to do with the "old" concept of theatre. Never-before-seen technical set-ups, rotating stages or numerous cinematic projections and loudspeaker sound systems were supposed to make possible a total theatre<sup>31</sup> the likes of which the world had never seen before. Most of these utopias remained sketches and were never realised. Mainly because these theatres were never built and the technology of the time could not realise these visions. (see also *The Mechanical Eccentricity* at the beginning of this text).

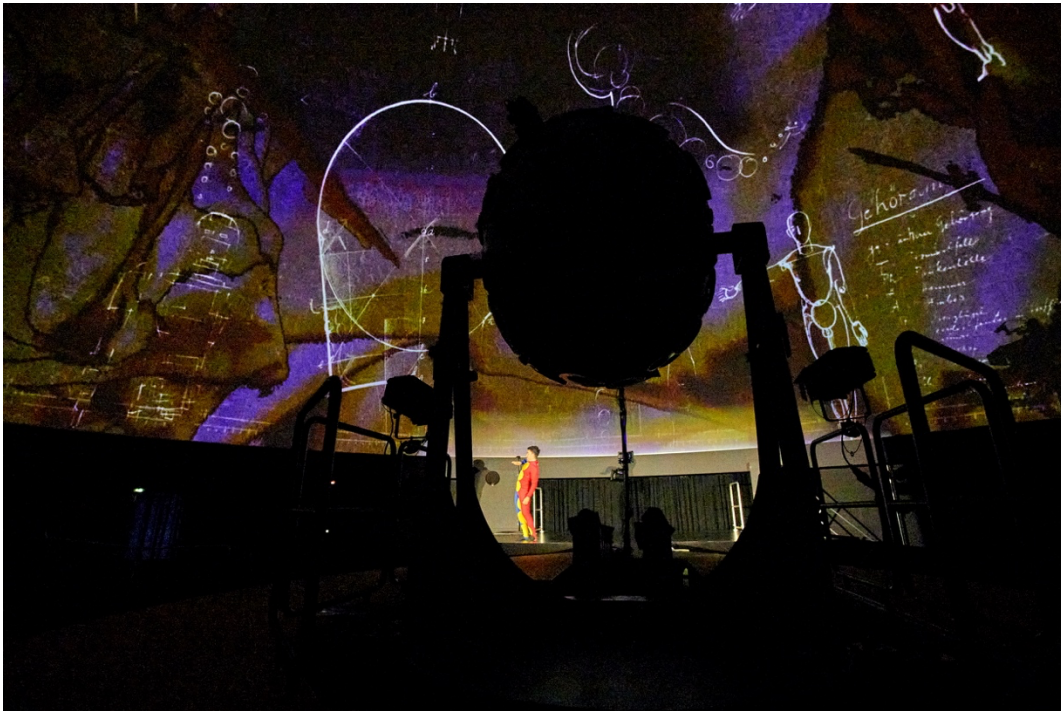

Figure 12. *Man and Art Figure in the Sphere Theatre*. Dancer: Christian Paul.  
Video by Yoann Trelu. Photo by Oliver Eltinger, 2021.  
THEATER DER KLÄNGE's Production, Düsseldorf, 2021.

In this full-dome play *Man and Art Figure in the Spherical Theatre* of the Theater der Klänge, the stage actors have to stand their ground against the sheer superiority of the multi-modally challenging space. Will they be able to stand up to the oversizing of almost the entire space surrounding them as a projection surface? Are their vocal utterances still perceptible and relevant in the immersive sound space? The task was to find answers to these questions and to focus the audience's concentration on the dancers' bodies again and again and to let the results of their actions, which expand medially into the projection dome and into the enveloping sound space, emanate from them and lead back to them. At the same time, the aim was not to celebrate the technology or the intermodal setting as such and to demonstrate the virtuoso use of it, but to let both the unusual action space and the playable media become an integrative and yet self-evident component of such a media-theatrical action.



Figure 13. 3D-Visualization of the "Total theatre" (Walter Gropius for Erwin Piscator)  
Available at [render.theaterderklaenge.de](http://render.theaterderklaenge.de)

## Conclusion

Let us return to Moholy-Nagy's postulate: "The design of form, movement, sound and light in a dynamic concentration of action will be "mechanical eccentricity." The goal of form, movement, sound and lighting design in a dynamic concentration of action is not mechanics and only to a limited extent eccentricity, but the meaningful interaction of a space as a projection and resonance theatre that appeals to both auditory and visual reception. Starting from the acting human being in this action space and its figurative, colourful, and gestural action possibilities at a certain point in time, in a certain musical-choreographic sequence for the purpose of reflection on a set theme for an audience that simultaneously receives, processes and, if necessary, aesthetically enjoys the complete multi- and intermodal offer as a total work of art.

It should not be concealed that in the 35 years of this preoccupation with multimedia, intermedia, but also multimodal in reception and inter-modal in handling questions for a "different" theatre with artistic directors and festival curators, we have had and continue to have considerable difficulties in accepting such an approach.

Just as all Bauhaus stage ideas were and still are rejected by theatre directors and, since the 1920s, by the entire dance world as being largely non-dance and irrelevant for the further development of theatre, we are repeatedly accused by the directors of theatres and festivals of not being a real dance ensemble or a real theatre of drama. Similarly, we are hardly ever classified as contemporary music theatre, let alone opera, and the contemporary music scene also has difficulties classifying our work as so-called new music. On the one hand, this is true, since our approaches and themes—as explained above—can hardly ever be assigned to one genre or another, but it makes the multimedia and multimodal approach a problem, since most existing houses and festivals define themselves in genre-specific terms and thus exclude cross-genre works or at best want to subordinate them to a genre dictate. Thus, a good 100 years after the first formulations of multimodal modern theatre forms (realised or sketched out as utopias), we continue to experience the greatest possible prevention or at best toleration of such theatre approaches. This is mainly due to the fact that the bourgeois theatre houses and festival curators—as well as the public authorities when awarding larger subsidies—tend to think in terms of dance or drama theatre, and for some years now also in terms of the so-called applied theatre sciences, but are hardly open to multimodal or intermodal open approaches to creation without the primacy of one of the classical genres mentioned above!

## Author Biography

Jörg U. Lensing has been a professor of Sound Design at the Dortmund University of Applied Sciences and Arts since 1996. He studied composition at the Folkwang University of the Arts in Essen from 1981 to 1987. He founded the series of concerts *Neue Töne* and the ensemble *Kunst-Stoff* during this time. First music theatre composition *Ich will zu Dir – Ach komm doch* for two dancers. In 1986 he won the Hochschulpreis at the Folkwang University of the Arts. 1987: exams in composition. From 1987 to 1989, he studied (post-graduate) New Music-Theatre with Mauricio Kagel at the University of Music and Dance in Cologne. In 1987 he founded the THEATER DER KLÄNGE in Düsseldorf. Since 1987 he has continued to work as a director, choreographer, and composer for theatre music until now, including 29 productions of this theatre and several compositions of incidental music for theatres and movies. Since 1990 he has also worked on film compositions and sound design for nearly all the films of German film director Lutz Dammbeck. In 1992 he was a guest lecturer in drama direction at the Bauhaus Dessau.

Email: joerg.lensing@fh-dortmund.de ORCID: 0000-0001-9681-3249



## Notes

1. In 2007 the former Folkwang Hochschule Essen became the Folkwang University of the Arts with campuses in Essen, Duisburg and Bochum.
2. At the time the ensemble was founded in 1987, there were offers for various music studies, theatre, pantomime, ballet and contemporary dance at the Hochschule Essen-Werden.
3. *The Stage at the Bauhaus* (Dessau: Bauhaus Books, 1925), (Mainz / Berlin: Florian Kupferberg Verlag, 1965)
4. The "mechanical ballet" is now called 'stage organisation with simple forms.' This new designation is more accurate, because by something mechanical one understands something only mechanical, this was not the case with the 'Mechanical Ballet,' because the forms were moved by people" (Kurt Schmidt)
5. Karl-Ernst Osthaus (\* 15. April 1874 in Hagen; † 27. März 1921 in Meran) from Wikipedia.
6. *Das mechanische Ballett: Directing&Choreografie* by J.U. Lensing. *Figurine-making* by Udo, J.U. Lensing, Ernst Merheim. Music by Hanno Spelsberg. See [www.theaterderklaenge.de](http://www.theaterderklaenge.de)
7. *Die mechanische Exzentrik: Performance score, direction and music* by J.U. Lensing, Stage construction by Jürgen Steger, Light slides and back pro video by Sascha Hardt, Music for the sequence "Electric apparatuses" by Thomas Neuhaus, Choreography of the *Human Mechanics* by Malou Airaud. See [www.theaterderklaenge.de](http://www.theaterderklaenge.de)
8. See *Audio-Vision* by Michel Chion and J.U.Lensing published by Schiele&Schön 2013
9. Ibid.
10. Eva-Elisabeth Fischer, *Süddeutsche Zeitung*, February 10, 1989.
11. *Figur und Klang im Raum: Score, direction, choreographies* by J.U. Lensing, Music by Thomas Neuhaus, Scenography and Light, Objects and Slides by Jürgen Steger. See [www.theaterderklaenge.de](http://www.theaterderklaenge.de)
12. GAMS: Gesture and Movement Sensor from the Canadian developer Will Bauer
13. The idea for such an electronic-interactive setup came from the composer Thomas Neuhaus in 1992–93, who subsequently also took over the development and a large part of the programming work.
14. The slide control computer was also supplied with a programming language by Thomas Neuhaus, while the digital/analogue interface for the projector control and the control of the mirror motors, as well as the mirror cabinet, were realised by our stage designer at the time, Jürgen Steger.
15. Action score and staging/choreography was done in both cases by the author of this article
16. Research documentation on PCI is available online at: [https://www.academia.edu/83783197/PCI\\_Forschungsbericht](https://www.academia.edu/83783197/PCI_Forschungsbericht)
17. Kinect is a hardware for controlling the video game consoles Xbox 360 and Xbox One, which has been sold by the company *Microsoft* since the beginning of November 2010.

18. The German programmer Frieder Weiß developed "Eyecon" over several years in collaboration with the dance ensemble *Palindrome*.
19. *HEAREOgraphics*: Director: J.U. Lensing, Music: Thomas Neuhaus, Video design: Lucy Lungley, Choreographic work: Jacqueline Fischer. See [www.theaterderklaenge.de](http://www.theaterderklaenge.de)
20. The highlight of this variation technique, derived from contrapuntal music and applied to dance, was our 2016 production *Die Kunst der Tanz-Fuge (The Art of the Dance Fugue)* from which a workshop programme was developed, which can be followed online via our virtual theatre: [www.theaterderklaenge.de](http://www.theaterderklaenge.de) and [render.theaterderklaenge.de](http://render.theaterderklaenge.de)
21. Research documentation on *IIP* is available online at: [https://www.academia.edu/68702604/Interaktive\\_intermediale\\_Performance\\_Ein\\_Forschungsbericht](https://www.academia.edu/68702604/Interaktive_intermediale_Performance_Ein_Forschungsbericht)
22. *MaxMsP* and *MaxMsP-Jitter* are developments of the company *Cycling74*, <https://cycling74.com>
23. For *Figure and Sound in Space*, a 10m wide and 5m high screen was set up in the back of the stage. In *HOEReographien* there was only a 5x4m screen in the backstage left. The right part of the 10m wide stages was hung out in black. The screen for *SUITE intermediale* was 10m x 4.30m. Originally, a larger round horizon screen was even planned for *SUITE intermediale*, but this was not realised because a larger black background was needed for keying.
24. *SUITE intermediale*: Directing by J.U. Lensing, Choreographic work by Jacqueline Fischer, Music by Thomas Neuhaus, Videodesign by Falk Grieffenhagen, Dancer by Sarah Biernat, Alex Carrillo, Bernardo Fallas, Catalina Gomez, Nina Hänel, Arthur Schopa. See [theaterderklaenge.de](http://theaterderklaenge.de)
25. See several stage presentations at the *US-Siggraph* or in Germany, for example, the festival *Temps d'images*.
26. *VANITAS*: Directing by J.U. Lensing, Music by Thomas Neuhaus, Choreographic work by Jacqueline Fischer, Videodesign by Fabian Kollakowski
27. *CODA*: Directing by J.U. Lensing, Music by Thomas Neuhaus, Choreographic work by Jacqueline Fischer, Videodesign by Tobias Rosenberger, Cello by Beate Wolff, Dancer Nina Hänel, Phaedra Pisimisi
28. *Das Lackballett*: Directing and Music by J.U. Lensing, Choreographic work by Jacqueline Fischer, Videodesign by Yoann Trelu, Figurines by Christian Forsen, Caterina Di Fiore.
29. *Der Mensch: Unterricht am Bauhaus* (Neue Bauhausbücher, Mann, Gebr.; 3. Edition 2014)
30. Oskar & Tut Schlemmer, *Briefe und Tagebücher* (Berlin, Deutsche Buch-Gemeinschaft, Albert Langen)
31. In fact, Walter Gropius designed a so-called "total theatre" for the Berlin theatre-maker Ernst Piscator in 1927, but it was never built. In 2021, the Theater der Klänge realised this theatre design as "The Virtual Total Theatre of Sounds" as a "walk-in" 3D online version, partly equipped with interactive contact points: [render.theaterderklaenge.de](http://render.theaterderklaenge.de)

## Bibliography

- Schlemmer, Oskar, László Moholy-Nagy, Farkas Molnár, Marcel Breuer, and Kurt Schmidt. *Die Bühne im Bauhaus*. München: Albert Langen Verlag, 1925. Reprint, Mainz and Berlin: Florian Kupferberg Verlag, 1965.
- , and Tut Schlemmer. *Briefe und Tagebücher*, Berlin: Deutsche Buch Gemeinschaft, Albert Langen, 1969.
- , and Heimo Kuchling. *Der Mensch: Unterricht am Bauhaus*. Berlin: Neue Bauhausbücher, Mann, 2014.
- Theater der Klänge – 10 Jahre auf dem Weg zu einem eigenen Theater*. Düsseldorf: Theater der Klänge e.V. and Theatermuseum Düsseldorf, 1997.
- 25 Jahre Theater der Klänge*. Düsseldorf: Theater der Klänge e.V. and Theatermuseum Düsseldorf, 2012.
- Theater der Klänge Bauhausbühne – Originale, Adaptionen, Weiterführungen*. Düsseldorf: Theater der Klänge e.V. and Theatermuseum Düsseldorf, 2019.
- Lensing, Jörg U. "PCI – Performer Computer Interaction," research report presented at Dortmund University of Applied Sciences and Arts, 2006.
- . "IIP – Interactive intermedia Performance," research report presented at Dortmund University of Applied Sciences and Arts, 2011.



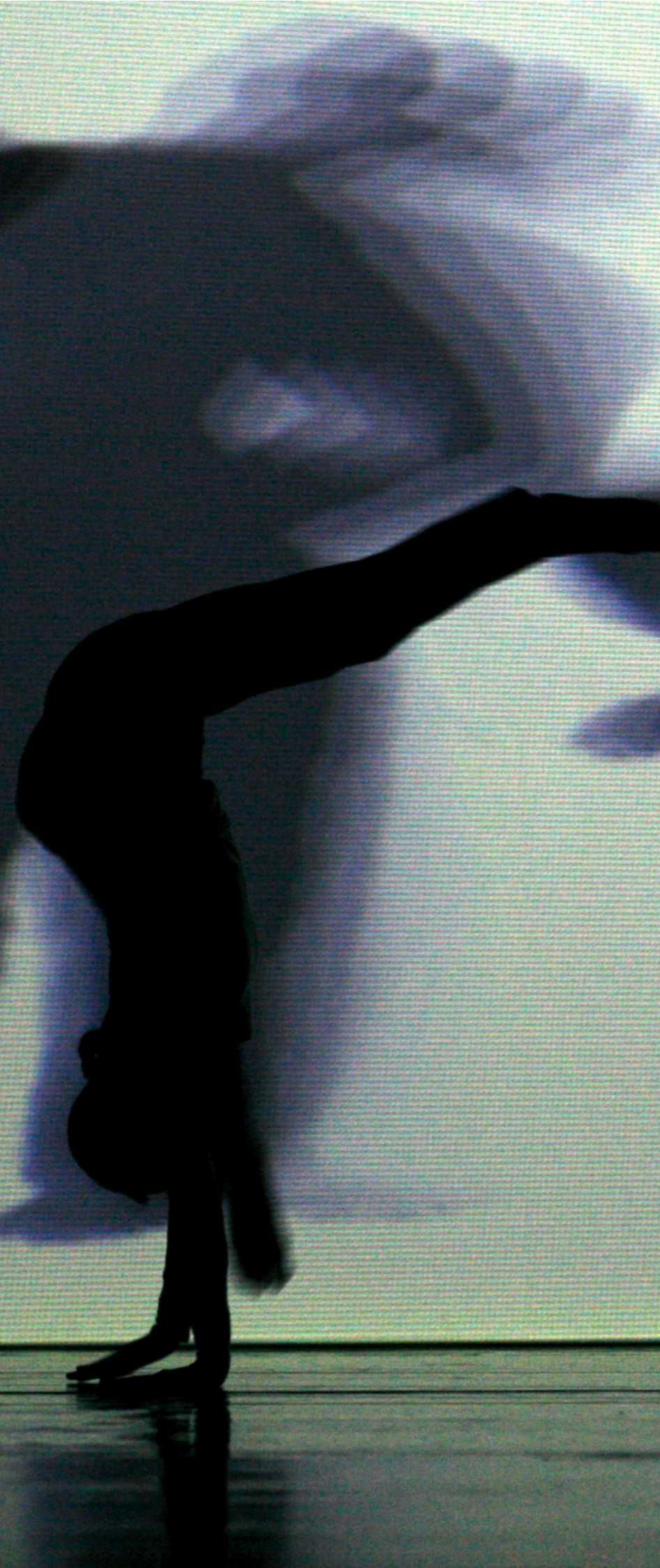

## The Art Style Magazine's Scientific Committee

**Dominique Berthet** is a University Professor. He teaches aesthetics and art criticism at the University of the French Antilles (UA). Founder and head of CEREAP (Center for Studies and Research in Aesthetic and Plastic Arts). Founder and director of the magazine *Recherches en Esthétique*. Member of CRILLASH (Center for Interdisciplinary Research in Literature, Languages, Arts, and Humanities, EA 4095). Associate Researcher at ACTE Institute (Université Paris 1 Panthéon-Sorbonne). Art critic, member of AICA-France (International Association of Art Critics). Exhibition curator. His research focuses on contemporary and comparative aesthetics, contemporary art, Caribbean art, and Surrealism. He has directed more than 50 volumes, published more than 110 articles and ten books among which: Hélénon, "Lieux de peinture" (Monograph), (preface Édouard Glissant), HC Éditions, 2006; André Breton, *l'éloge de la rencontre*. Antilles, Amérique, Océanie, HC Éditions, 2008; Ernest Breleur (Monograph), HC Éditions, 2008; *Pour une critique d'art engagée*, L'Hamattan, 2013.

**Gary Bratchford** runs photography projects, writes, and teaches photography at the University of Central Lancashire (UCLan), where he is a Senior Lecturer. He is also the President of the International Sociological Associations' Visual Sociology Research Group and co-editor of the Journal *Visual Studies*. Gary's teaching and research focus around notions of power, politics, visibility and space. Gary's photographic practice centres on collaborative and participatory visual practices, including socially engaged, process-based community projects. He participated in many international conferences and forums, published in conference proceedings, and several international academic journals. Among his publications in these fields are the recent articles *Socially Engaged Photography and Wellbeing: Reflections on a Case Study in the Northwest of England*. (2019) *Visualising the invisible: a guided walk around the Pendleton Housing Estate*, Salford, UK.

**Hans-Dieter Huber**, artist, filmmaker, scientist. 1997 to 1999 professor HGB Leipzig; 1999-2019 Professor of Contemporary Art History, Aesthetics and Art Theory at the State Academy of Fine Arts Stuttgart. 2006-2011 Head of the International Master Program "Conservation of New Media and Digital Information" at the State Academy of Fine Arts Stuttgart. 2007 Senior Fellow at the International Research Center for Cultural Studies in Vienna. 2006-2009 Professor at the Post Graduate Program "Image, Body, Medium" at HfG Karlsruhe. Since 2013 Member of the Scientific Advisory Board of the International Institute for Subjective Experience and Research (ISER) at the MSH Medical School Hamburg. Since 2015 member of the scientific board of Society for Interdisciplinary Image Science (GIB). Since 2016 Deputy Chairman of the Württembergischer Kunstverein Stuttgart. From 2017-2020 Member of the Board of Trustees of the Adolf Hölzel Foundation, Stuttgart.

**Lars C. Grabbe**, Dr. phil., is Professor for Theory of Perception, Communication and Media at the MSD – Münster School of Design at the University of Applied Sciences Münster. He is managing editor of the Yearbook of Moving Image Studies (YoMIS) and the book series *Bewegtbilder/Moving Images* of the publishing house Büchner-Verlag, founder member of the Image Science Colloquium at the Christian-Albrechts-University in Kiel (Germany) as well as the Research Group Moving Image Science Kiel | Münster (Germany). He is working as scientific advisor and extended board member for the German Society for Interdisciplinary Image Science (GiB). Furthermore, he is a member of the International Society for Intermedial Studies, the German Society for Semiotics (DGS) and the German Society for Media Studies (GfM). His research focus lies in phenosemiotics, media theory, and media philosophy, image science, perception studies and psychology of perception, communication theory, aesthetics, semiotics, film studies and history of media as well as theory of embodiment and cognition.

**Marc Jimenez** is a professor emeritus of aesthetics at University Paris 1 Panthéon-Sorbonne, where he taught aesthetics and sciences of art. With a PhD in literature and a PhD in philosophy, he translated from German into French T.W. Adorno's *Aesthetics*, August Wilhelm Schlegel's philosophical *Doctrines of Art*, and Peter Bürger's *Prose of the Modern Age*. Since 1986, when he succeeded Mikel Dufrenne, he directed the aesthetics collection Klincksieck Editions Collection d'Esthétique, Les Belles Lettres. Professor Marc Jimenez is a specialist in contemporary German philosophy, and his work contributed, in the early 1970s, to research on Critical Theory and the Frankfurt School. He is also a member of the International Association of Art Critics, participates in many conferences in France and abroad, and has been a regular contributor to art magazines. Recent publications: *La critique : crise de l'art ou consensus culturel ?* (Klincksieck, 1995), *Qu'est-ce que l'esthétique ?* (Gallimard, 1997), *La querelle de l'art contemporain* (Gallimard, 2005), *Fragments pour un discours esthétique. Entretiens avec Dominique Berthet* (Klincksieck, 2014), *Art et technosciences. Bioart, neuroesthétique* (Klincksieck, 2016), *Rien qu'un fou, rien qu'un poète. Une lecture des derniers poèmes de Nietzsche* (encre marine, 2016).

**Omar Cerrillo Garnica** is a Mexican researcher (SNI-1) and professor in Cultural Sociology. He got a PhD in Social and Political Sciences and a Master's Degree in Sociology at Iberoamerican University in Mexico City, graduated with honors. Since 2007 is professor at Instituto Tecnológico y de Estudios Superiores de Monterrey, in 2019 becomes Director of Humanities School at Campus Cuernavaca. He is specialized in social analysis of art, music and culture. He also developed a successful community engagement social service program through arts and sports. As a researcher, he has worked in politics in music –rock, Mexican folk genres–, cultural policies, digital culture, and cyberactivism. He has participated in many academic events in Mexico and other countries, with articles and book chapters published in Mexico, Brazil, Chile, and France.

**Pamela C. Scorzin** is an art, design, and media theorist and Professor of Art History and Visual Culture Studies at Dortmund University of Applied Sciences and Arts, Department of Design (Germany), since 2019, vice-dean. Born 1965 in Vicenza (Italy), she studied European Art History, Philosophy, English and American Literatures, and History in Stuttgart and Heidelberg (Germany), obtaining her M.A. in 1992 and her Ph.D. in 1994. She was an assistant professor in the Department of Architecture at Darmstadt University of Technology from 1995 to 2000. After completing her habilitation in the history and theory of modern art there in 2001, she was a visiting professor in Art History, Media and Visual Culture Studies in Siegen, Stuttgart, and Frankfurt am Main. Since 2008 Professor of Art History in the Department of Design at the Dortmund University of Applied Sciences and Arts; since 2020 Vice-Dean. Since 2005, she is a member of the German section of AICA. She has published (in German, English, French, and Polish) on art-historical and cultural-historical topics from the seventeenth to the twenty-first century. She lives and works in Dortmund, Milan, and Los Angeles.

**Waldenyr Caldas** is a full professor in Sociology of Communication and Culture at the University São Paulo. He was a visiting professor at University La Sapienza di Roma and the Joseph Fourier University in Grenoble, France. Professor Caldas has been a professor since 1996 as well as the vice-director (1997-2001) and Director (2001-2005) of ECA - School of Communications and Arts, University of São Paulo. In his academic career, he obtained all academic titles until the highest level as a full professor at the University of São Paulo. Currently, he is a representative of the University of São Paulo, together with the Franco-Brazilian Committee of the Agreement "Lévi-Strauss Chairs," and a member of the International Relations Committee of the University of São Paulo. Its scientific production records many books published and several essays published in magazines and national and international collections.

# Art Style | Art & Culture International Magazine

Art Style Magazine is an open access, biannual, and peer-reviewed magazine

## Submission

*Art Style Magazine* publishes both themed issues and issues with a variety of themes. If you are interested in publishing in the current themed edition, check out the call for papers for details on the upcoming editions. You are also welcome to contribute an extended essay or scholarly article on one of our past issues' themes or a new subject. You just need to follow our [Author Guidelines](#) and submit your essay or scholarly article for evaluation. We will get back to you with acceptance or nonacceptance feedback after the reviewers have evaluated your contribution. If your submission is accepted, we will inform you about the publication schedule.

## Peer-Review Process

Papers submitted to *Art Style Magazine* are subject to strict peer review and published in the online issue when two external reviewers have approved them. Deadlines and publication dates are designated in each respective issue's planning stages. We will get back to authors with acceptance or nonacceptance feedback after the reviewers have evaluated the contributions, and we will inform them about the publication schedule.

## Plagiarism

Papers submitted to *Art Style Magazine* are automatically checked for plagiarism; if a paper is plagiarized, it will not be accepted. All published articles go through the plagiarism scanner and must meet the ethical standards of academic conduct. If plagiarism is discovered in a published article, the plagiarized piece will be removed, and the author will no longer be able to publish in this magazine.

## Research Publishing Ethics

*Art Style Magazine* outlines the best practice principles for publications. We defend the best practices in our publications and follow top institutions' directions on teaching, science, and research worldwide. With this practice, we wish to remember the fundamental values of recognition of merit and the originality of researchers and authors. Therefore, we present here the central notions of good conduct and research publishing ethics, based on the [Committee on Publication Ethics \(COPE\)](#), the [United States National Science Foundation's](#) policies and procedures, the [European Science Foundation's](#) code of conduct, and the [FAPESP São Paulo Research Foundation's](#) code of good scientific practice.

## License and Publishing Agreement

Authors are required to sign a License and Publishing Agreement, when a paper is accepted for publication, retaining copyright while allowing the *Art Style Magazine* to publish under the terms of that agreement. Authors of *Art Style Magazine* are invited to accept and agree to be bound by the terms and conditions of Creative Commons Attribution License (CC BY-NC-SA 4.0).



## Author Guidelines

Language: American or British English. Everything written should be proofread.

The extended essay should be submitted to [editorial@artstyle.international](mailto:editorial@artstyle.international)

### Required structure

Required structure of the extended essay: title; abstract (approx. 300 words); introduction; body of the essay; conclusion; author biography (at least 150 words), endnotes, bibliography (only authors cited in the text should be referred to in the bibliography). Please, use The Chicago Manual of Style system, in Microsoft Word format (.docx). The extended essay must be of a word count of minimum 3,000 and maximum 5,500 (excluding figures, endnotes and bibliography). Page setup A4 (210 by 297 mm), default settings (based on the normal Microsoft Word template). Title: Times New Roman 16 pt, flush left. Sub-title: Times New Roman 14 pt, flush left. Sub-section Heading: Times New Roman 14 pt, flush left. Text body: Times New Roman 11 pt. Line spacing: 1.15, justified. Quotations: more extended quotations should be single-spaced and separated from the text. Also, we accept scholarly articles with a limit of 8000 words (including endnotes and bibliography). Page setup A4 (210 by 297 mm), default settings (based on the normal Microsoft Word template).

Figures: images are required—color or monochrome in RGB color mode. Please, set the resolution of images destined for web pages to 72dpi, and save images in jpg or png format only. Resolution: between 1500 and 2500 pixels wide. Don't enlarge a small image to avoid pixelated images. The related images to incorporate into your paper should have permission from the image owner or use pictures in the public domain. You can choose royalty-free photos with a Creative Commons or similar license. Otherwise, you can create some images of your own. The editorial team will evaluate the images and choose the most appropriate. The author is responsible for the images used in the article, attending to the recommendations indicated in this guide, besides using the image under [Creative Commons Attribution License \(CC BY-NC-SA 4.0\)](https://creativecommons.org/licenses/by-nc-sa/4.0/).

### Captions for figures

Works of art can be cited using this format:

Figure 1: Artist's name, *Title*, Date, Medium, and support. City, Collection. License information.

But include the publication citation for where the artwork's image was found unless you have viewed the artwork in person. Any image that is being reproduced publicly should consider adding copyright information, i.e., who owns the right to an image or if it is under a Creative Commons Attribution License.

**Before you submit your essay, please ensure your paper is ready for submission.**

Essays and articles submissions that do not meet these recommendations will be returned.

For more information, please see:

[The Chicago Manual of Style](#) and [Magazine's Author Guidelines](#)

## Terms & Conditions

Publishing in *Art Style Magazine* is free of charge for anyone, there are no article processing charges or other publication fees. *Art Style Magazine* is independent and supports the [Open Access Movement](#). *Art Style Magazine* is following what is recommended in international guidelines of the [Berlin Declaration on Open Access to Knowledge in the Sciences and Humanities](#).

This magazine is available under the Creative Commons Attribution License (CC BY-NC-SA 4.0). All authors (have) permitted the publication under this license. There is no copyright transfer towards *Art Style Magazine*, the authors hold the copyright and publishing rights without restrictions. Papers submitted to *Art Style Magazine* are automatically checked for plagiarism; if a paper is plagiarized, it will not be accepted. All published articles go through the plagiarism scanner and must meet the ethical standards of academic conduct. If plagiarism is discovered in a published article, the plagiarized piece will be removed, and the author will no longer be able to publish in this magazine. The editors of *Art Style Magazine* cannot be held responsible for errors or any consequences arising from the use of information contained in essays published on the *Art Style Magazine's* website. Authors agree to the terms and conditions and assure that their submissions are free of third parties' rights. The views and opinions expressed in the essays are those of the author and do not reflect the views of *Art Style Magazine*. The authors of *Art Style Magazine's* essays are responsible for its content. Images from other sources should be fully acknowledged in the caption. The *Art Style Magazine* website provides links to third-party websites. However, the magazine is not responsible for the contents of those linked sites, nor for any link contained in the linked site content of external Internet sites.

### Editor-in-Chief and Creative Director

**Christiane Wagner** is the editor-in-chief, founder, and creative director of the *Art Style, Art & Culture International Magazine*, and a member of the College Art Association of America in New York. She has been a visiting research professor at the University of São Paulo. She was a research visiting professor of aesthetics and science of communication, UNICAMP (Fellowship CAPES 2014–2018, qualification for a professorship, Habilitation, Venia Legendi). Both universities (USP and UNICAMP) are ranked as the best universities in Latin America. She was awarded a doctoral degree (Promotion 2014) in Germany in the science of art and aesthetics, recognized by the Hessian Ministry of Science and Art. She has a Ph.D. in science of art and aesthetics from Université Paris 1 Panthéon-Sorbonne with highest honors (mention très honorable/summa cum laude). Also, she holds a Ph.D. in design and architecture (with highest honors) and a master's degree in science of communication (with highest honors) from the University of São Paulo. She gave lectures and participated in panel discussions at the Stuttgart State Academy of Art and Design, Germany; L'École des Arts de la Sorbonne – Université Paris 1 Panthéon-Sorbonne; Universität Wien; Contemporary Art Museum of the University of São Paulo (MAC USP); Institut für Kunstgeschichte, FAU – Friedrich Alexander Universität, Erlangen Nürnberg; The City University of New York (CUNY), New York City College of Technology (City Tech); University of Hertfordshire, London, and in many international conferences. Prof. Dr. Christiane Wagner is a scientific advisor of the São Paulo Research Foundation FAPESP in cooperation agreements with national and international research funding agencies including the UK Research Councils, the Agence Nationale de Recherche (ANR) in France, the Deutsche Forschungsgemeinschaft (DFG) in Germany, and the European Commission. She has several publications, including peer-reviewed articles, books, and essays in German, English, French, and Portuguese, some of the many languages, including Spanish, in which she is fluent.

## Senior Editor

**Martina Sauer** is a scientific advisor at the Society of Interdisciplinary Image Science and the German Society of Semiotics. She is currently a lecturer in the fundamentals of perception at the AMD Akademie Mode & Design in Hamburg and Düsseldorf. In her career she was a scientific associate in philosophy of art, aesthetics, and design in Basel, Zürich, Bremen, and Witten, as well as a scientific associate at Bauhaus-University Weimar.

## Associate Editors

**Dimitra Laurence Larochelle** is post-doctoral scholar at the Université Polytechnique Hauts-de-France. She holds a PhD in Sociology and Cultural Studies from the University Sorbonne Nouvelle - Paris 3. She has worked as lecturer in various French universities, and she has worked as a researcher in France as well as in Cyprus. She is member of the board of the Research Committee 14 (Sociology of Communication, Knowledge and Culture) of the ISA (International Sociological Association) and Youth Representative at the United Nations for the ISA (International Sociological Association).

**Katarina Andjelkovic**, Atelier AG Andjelkovic, with a PhD, M. Arch. Eng., is a theorist, practicing architect, researcher and a painter. Katarina's research, writing and teaching is transdisciplinary and crosses architecture, visual arts and film. She served as a Visiting Professor at the University of Oklahoma (the US), at the Institute of Form Theory and History in Oslo, Institute of Urbanism and Landscape in Oslo, the University of Belgrade, and guest-lectured at TU Delft, AHO Oslo, FAUP Porto, DIA Anhalt Dessau, SMT New York, ITU Istanbul. She has lectured at conferences in more than twenty-six countries in Europe, the UK, the US and Canada; has published her research widely in international journals (Web of Science); won numerous awards for her architecture design and urban design competitions. Katarina won the Belgrade Chamber of Commerce Award for Best Master Thesis defended at Universities in Serbia in all disciplines. Katarina has published two monographs; a book chapter and several journal articles with Intellect.

**Natasha Marzliak**, Adjunct Professor of History and Aesthetics of Art at the Federal University of Amazonas (UFAM). Doctorate in Visual Arts - Multimedia and Art at UNICAMP, with a research exchange in Cinema and Audiovisual at Université Paris 1 Panthéon-Sorbonne. Master in Visual Arts - Audiovisual Culture and Media. Bachelor of Fine Arts and Bachelor's Degree in Art Education. As a complementary training, she holds a Diploma of Advanced Studies in French Language from Université Paul Valéry - Montpellier III and has studied subjects such as French Language, Culture and Civilization in France, Cinema, History of Art and Literature. She works in the areas of Aesthetics, Art History, Visual Culture and Visual Arts, with an emphasis on the intersections of contemporary art with cinema, video and new technologies.

Art Style Maganize's website: [artstyle.international](http://artstyle.international)



## Art Style | Art & Culture International Magazine

editorial@artstyle.international

+1 347 352 8564 New York  
+55 11 3230 6423 São Paulo

The Magazine is a product of Art Style Communication & Editions.  
Founded in 1995, the Art Style Company operates worldwide in the fields  
of design, architecture, communication, arts, aesthetics, and culture.

Theodor Herzi, 49 | 05014 020 Sao Paulo, SP | CNPJ 00.445.976/0001-78

Christiane Wagner is a registered journalist and editor: MTB 0073952/SP

© 1995 Art Style Communication & Editions



artstyle.international | Volume 10 | Issue 10 | September 2022

# ART STYLE

Art & Culture  
International  
Magazine

ISSN 2596-1802



9 772596 180008

