

Axes and Metal Deposits in the Caucasus from the 5th to the 2nd Millennium BCE

Svend Hansen

Abstract

In this article the development of the shaft-hole axes from the 5th to 3rd millennium BCE is presented. On the one hand, the technical innovation history of these axes is illuminated in the light of existing radiocarbon dating. According to the current evidence of ¹⁴C data, the shaft-hole axe of the Maikop type was developed in the context of the North Caucasian Maikop Culture. Older models are not documented. It is argued that axes of this type were already used in the Carpathian Basin in the 4th millennium BCE. Axes of this shape can still be found in every building supplies store today. The history of innovation of shaft-hole axes is discussed against the background of the tendencies in metal deposition. The deposition of copper and bronze axes was carried out under the compelling need to make sacrifices to imaginary powers. Only for this reason have metal axes been preserved in archaeological finds.

Introduction

In the 4th millennium BCE the shaft-hole axe was one of the most striking and momentous innovations in the history of Eurasian armament (Fig. 1). It was extremely successful, for its manufacture apparently succeeded without major problems in many regions between the Taurus and Caucasus Mountains in the East and as far as the Alps in the West. As is often the case with innovations, the technical prerequisites had already existed for a long time. Namely, since the 5th millennium BCE, copper hammer axes or axe-adzes had been produced in the Carpathian Basin and also elsewhere. The shifting of the shaft-hole to the heel of the axe gave it a much higher penetrating power and more precise handling than that of its predecessors. This form is still produced today. The development and production of the shaft-hole axe began as early as the first half of the 4th millennium BCE and continued parallel to other fundamental innovations

in metallurgy. These included new casting techniques, such as casting in the lost wax form and cupellation, i.e. the separation of silver and lead.

Yet the most momentous innovation was the technique of alloying copper with arsenic, which turned the soft copper into hard and elastic bronze. Evgeniï N. Chernykh clearly identified this decisive step in metal technology and – in contrast to Carpathian-Balkan metallurgy – called it “Circumpontic Metallurgy Province (CPM)”¹. Already in his pioneering work on the history of ancient metals, Chernykh was able to connect the different, chemically defined groups with archaeological periods and cultures². The development of new technical recipes was the result of the experimentation with different metals, as documented by the wide range of metals found at Nahal Mishmar on the Dead Sea³. Alloying had several optimising consequences. For example, the arsenic alloy made it possible to produce functional dagger blades⁴. The blades became harder, but remained elastic and did not become

1 Chernykh 1992.

2 Chernykh 1966.

3 Bar-Adon 1980; Tadmor *et al.* 1995; Gilead/Gošić 2014.

4 Lechtman 1996; Hansen in print.

Fig. 1 Shaft-hole axes from Hungary.

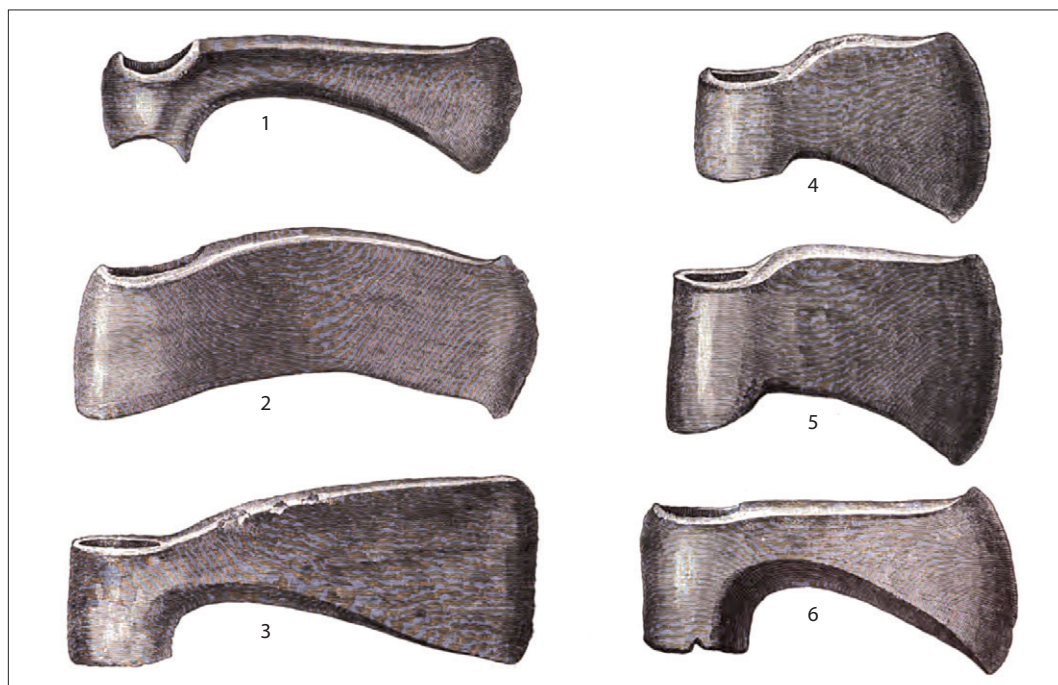

brittle. Casting was also made easier by lowering the melting point of the copper. By adding arsenic or tin, the formation of bubbles in the molten metal mass was reduced, thus preventing the formation of casting shrink-holes or cavities⁵. Such casting shrink-holes could have serious consequences, especially in long dagger blades. Finally, these improvements in casting opened up a huge scope of possibilities, in which practically any conceivable shape could be cast in metal. There were almost no limits to the production of metal objects. In Nahal Mishmar – at the end of the 5th millennium BCE – complex crowns with animal figures, large long staffs, the first cast metal vessels and a wealth of different, individually designed standards were found (*Fig. 2*). This stands in stark contrast to the monotone spectrum of adzes and axes in the Balkan Copper Age.

These significant developments in the production of copper or bronze tools and weapons were part of a multitude of key innovations that emerged in the 4th millennium BCE and were the prerequisite – and perhaps in part the re-

sult – of what Gordon Childe called the “urban revolution”. To name only the most important innovations: the wheel and cart, the potter’s wheel, the breeding of a sheep with woolly fleece, the domestication of the donkey and the horse, the cultivation of olives and wine, writing and the administration of goods by means of seals, the appearance of cities and states. Each of these innovations had considerable economic, social and cultural consequences. Guillaume Gernez writes: “Cette étape conceptuelle, franchie grâce aux spécificités plastiques du métal et à la maîtrise des techniques de fonte et de moulage, est un moment majeur à la fois de l’histoire des techniques mais aussi de celle de l’outillage et de l’armement”⁶. The innovations in metal technology had a direct impact on the possibilities of the use of violence.

The history of the formal shape of the shaft-hole axes was basically worked out by Alexandru Vulpe⁷. A little later Chernykh also presented a classification of the shaft-hole axes, basing on Bulgarian findings⁸. Sergeï N. Korenevskii,

⁵ Hansen 2017a.
⁶ Gernez 2007, 117.

⁷ Vulpe 1970.
⁸ Chernykh 1978, 135–148.



Pavel Kuznetsov, Barbara Helwing and Valentin A. Dergachev also dealt with various aspects of the production, type classification and research history of the shaft-hole axes⁹. The early axes are characterized by a relatively compact unstructured body. The later shaft-hole axes of the 3rd millennium BCE, however, are more articulated, with the shaft tube clearly separated from the blade. Nonetheless, there is often a need for better documentation of the finds and their details in drawings and photographs. The assessment of the axes is mainly based on their outline. Only a comprehensive study of the original finds can clarify the relationship between various factors such as composition, alloy, weight, outline, shape of the shaft hole, etc.

One cannot simply write the development of innovations in metal weapons and metal tools on the basis of the existing find material. Rather, a precise source critique is needed to recognise, identify and explain the presence and absence of finds. The question must be asked as to what the absence or existence of metal finds might be connected with. Namely, the normal course of metal in the circulation cycle is recycling. Material that had become unusable was melted down again and from it new weapons or tools were cast. This was the usual cycle well into the 21st century AD. The share of secondary copper in the annual cop-

per production today is about 30%. Therefore, the absence of metal should actually be the rule. In fact, there are cases of this. For example, only very few metal objects have survived from the Hittite Empire. A prominent exception is the well-known sword from Hattusa, dedicated to the weather god¹⁰.

Almost all metal objects that fill archaeological museums today were once gifts for the deceased or for imaginary powers, spirits and gods. Therefore, the history of the shaft-hole axe can only be written in the context of its deposition in graves and in hoards as well as individual, single deposits. Deposition is the medium through which the tradition of these objects was made possible in the first place¹¹.

Depositions

The Danish archaeologist Jens Jacob Asmussen Worsaae presented the first scientifically based interpretation of the hoards in 1866¹². He had observed that certain groups of objects, e.g. the lures, were almost always found in pairs in bogs, but never in graves. He also noticed that the objects were almost always damaged and destroyed, which was also true for objects in numerous other hoards. Worsaae also included the Iron Age bog finds in his observations and recognized remarkable similarities in the way the objects were destroyed, e.g. the swords¹³. He thus argued on the basis of his precise observation of the objects and the observation of patterns in deposition and destruction, which, moreover, overlapped in time. This led him to the conclusion that the hoards were not hidden treasures, but offerings. He concluded his remarks with the expectation that these new insights were relevant not only for the North, but also for the rest of Europe.

Unfortunately, work in research did not follow Worsaae's lead to examine the find material with view for recurring characteristics, but instead it categorized the hoards, for example, as

Fig. 2 Nahal Mishmar, Israel: earliest evidence of casting in the lost wax form.

9 Korenevskii 1974; Kuznetsov 2009; Helwing 2017; Dergachev 2018.
10 Ertekin/Ediz 1993.

11 Hansen 2013b.
12 Worsaae 1866.
13 Worsaae 1866, 318 with illustrations.

founders' hoards or metal dealers' hoards, according to "common sense"¹⁴. This "utilitarian" interpretation remained decisive for a long time, especially in Central and Western Europe. In the German-speaking sphere, the term 'hoard', which is widely used today, referred to the Song of the Nibelungs¹⁵. The huge treasure (*Hort*) of the Nibelungs played a central role there until it was thrown into the Rhine by Hagen of Tronje.

In 1903 Oskar Montelius limited the term 'hoard' to 'closed finds' containing at least two objects¹⁶. This was a necessary prerequisite for his primary concern to establish a reliable chronology, but it proved to be restrictive for the scientific treatment or interpretation of the hoards. According to Montelius, hoards were defined by a norm according to which they should contain at least two objects laid down at the same time. In this way, the find ensembles that had been created or accumulated over a longer period of time were sorted out through the examination of the depositions. Equally as restrictive was the fact that the so-called single finds remained largely excluded from consideration. This presented an obstacle to a differentiated examination of the depositing process. Namely, the single finds are not accidentally lost objects, but for the most part one-piece deposits.

Therefore, in the analysis of the hoards, only a scientifically defined segment from a much broader spectrum of depositions was regarded. This narrowed the field of possible interpretations considerably. The interpretation of undamaged bronzes as dealers' hiding places and fragmented objects as foundry supplies was as assertive as it was distant from the subtle observations of an archaeologist like Worsaae. The multi-piece hoards in whatever composition were only one part of a more comprehensive practice of deposition, a tradition which included water finds, single finds in the solid ground and ultimately also grave goods, and which can only be understood from their overall view.

Wherever hoards are absent, there are often water finds or many single finds¹⁷. This problem plays a specific role especially in the early history of depositions: indeed, the single deposition of hatchets and axes is a dominant phenomenon between the 5th and 3rd millennium BCE.

The assertion that hoards and single finds were accidental losses has never been made even remotely plausible. This had consequences for the lack of intellectual penetration of the problems behind the phenomenon of hoarding. However, this also resulted in very practical deficits: the circumstances and places of finds were hardly taken into account, which in turn led to the fact that many sites are often very poorly documented. If the hoards had been regarded as votive offerings to imaginary powers, more attention would have been paid to the sites. Namely, a place assumed 'sacred' would undoubtedly have been considered more interesting than the hiding place or cache of a scrap-metal dealer.

Bronze hoards have long been viewed in isolation, according to periods in time, because there is of course little point in writing a history about accidental losses or caches of scrap-metal dealers. Only the interpretation of the hoards as votive offerings to the imaginary powers makes it possible to examine depositions over a period of several hundred or even a thousand years. The investigation of the deposits throughout time was stimulated in particular by the modern-day regulations of rivers or, more generally, finds retrieved from waters, as these discoveries range in date from the Neolithic period to the Middle Ages¹⁸.

A series of recent cross-period studies shows the temporal continuity of depositions and thus also allows a new view of the long lines of tradition in the cultural landscape¹⁹. For example, Lise Frost was able to impressively demonstrate the micro-regional density of depositions in northwest Sjælland, from the Funnel Beaker period of the 4th millennium BCE to the Early

14 Chantre 1873; Chantre 1875–1876, 68; Evans 1881; Richlý 1896; Schumacher 1903; Truhelka 1909b, 55.

15 Seger 1936.

16 Montelius 1903, 3–11.

17 Hansen 1994.

18 Torbrügge 1970–1971; Wegner 1976; Hansen 1991; Blažek/Hansen 1997; Hansen 2000; Wirth 2000; Frost 2013.

19 Winghart 1986.

Bronze Age²⁰. The Irish hoards, too, have turned out to be essentially ritualistic in the cross-period consideration²¹.

The recontextualisation of the hoards and single finds to the place of deposition has made clear the regionally different connection of hoards to certain topographical locations²². Recently, it could be shown that the metal finds of the 5th and 4th millennia BCE in Poland were deposited regionally very differently: in Silesia – more often in graves, in south-eastern and central Poland –with reference rather to waters²³. Maria Windholz-Konrad was able to document the small-scale density of deposits along old roads²⁴. The investigation of such deposition sites has been carried out in only few cases, for example, in Inzigkofen, Kr. Sigmaringen, on the upper Danube River²⁵.

Hoards can be viewed under the aspects of crafts, economics, trade or religious history. They contain products of handicrafts, some of them representing considerable values and containing objects from different regions. Finally, they were deposited as votive offerings for the imaginary powers, spirits and gods. Thus, in their final function the metal objects were gifts. If we follow Marcel Mauss, the gift in exchange is also a polyvalent object. The archaic exchange is an institution, in which all institutions of society are interwoven; everything is mixed here. Mauss speaks of a “total” social phenomenon, in which all kinds of institutions are expressed simultaneously and at once: religious, legal and moral and economic, “not to mention the aesthetic phenomena into which those facts flow”²⁶.

The beginnings of hoards

The logics of depositions become understandable in the *longue durée* perspective²⁷. Only recently it turned out, that they are part of a long tradition of deposition, which goes back to the Copper Age of the 5th millennium BCE. Early hoards with copper objects were found in the settlement of Pločnik, about 300 km south of Belgrade (*Fig. 3*)²⁸. Most copper axes of this time were deposited in south-eastern Europe, but occasionally they also found their way into northern Europe²⁹. An axe-adze even reached the island of Elba in the West³⁰. Unfortunately, there is no comprehensive study yet that deals with the deposition forms of these early metal finds outside of the Carpathian Basin.

The counterpart to the deposition of copper axes in south-eastern Europe were the jadeite axes in western and central Europe³¹. Their deposition began in the last quarter of the 6th millennium BCE, and they were still in use until the late 4th millennium BCE. Since the early 5th millennium BCE, basically the idea of the axe as an exquisite object for deposition covered all of Europe: in the West with the jadeite axes, in the East with the heavy copper tools. Here indeed lies the foundation of the entire later development of depositions. The five axes of Mainz-Gonsenheim (*Fig. 4*) were found as early as 1850 on the Kästrich hill near Gonsenheim. According to the finders, the axes had been placed in a leather case, probably to protect the blades from damage. The axes have a pointed neck and only moderately sharp or blunt edges. They are very flat, namely only between 1.1 and 2.3 cm in thickness. The surface is very carefully smoothed and polished³².

20 Frost 2008, 47, Fig. 27.

21 Becker 2013.

22 Hansen 2008; Yates/Bradley 2010; Hansen 2012; Scholz 2012; Neumann 2015; Vachta 2016.

23 Nebelsick/Lyszkowicz 2018, 41–42, Figs. 13–14.

24 Windholz-Konrad 2003; Windholz-Konrad 2005.

25 Reim 2009.

26 Mauss 1968.

27 Jeunesse 2017; Hansen 2019.

28 Finds presented in Stalio 1964, 35 and in Stalio 1973, 157; cp. also Borić 2009, 209–214; Šljivar/Kuzmanović-Cvetković/Jacanović 2006, 255.

29 Boroffka 2009, 249, Fig. 3; Govedarica 2010a; Dobeš 2013; Nebelsick/Lyszkowicz 2018.

30 Acconcia/Milletti 2015, 234, Fig. 7.

31 Pétrequin *et al.* 2012.

32 Heide 2003.

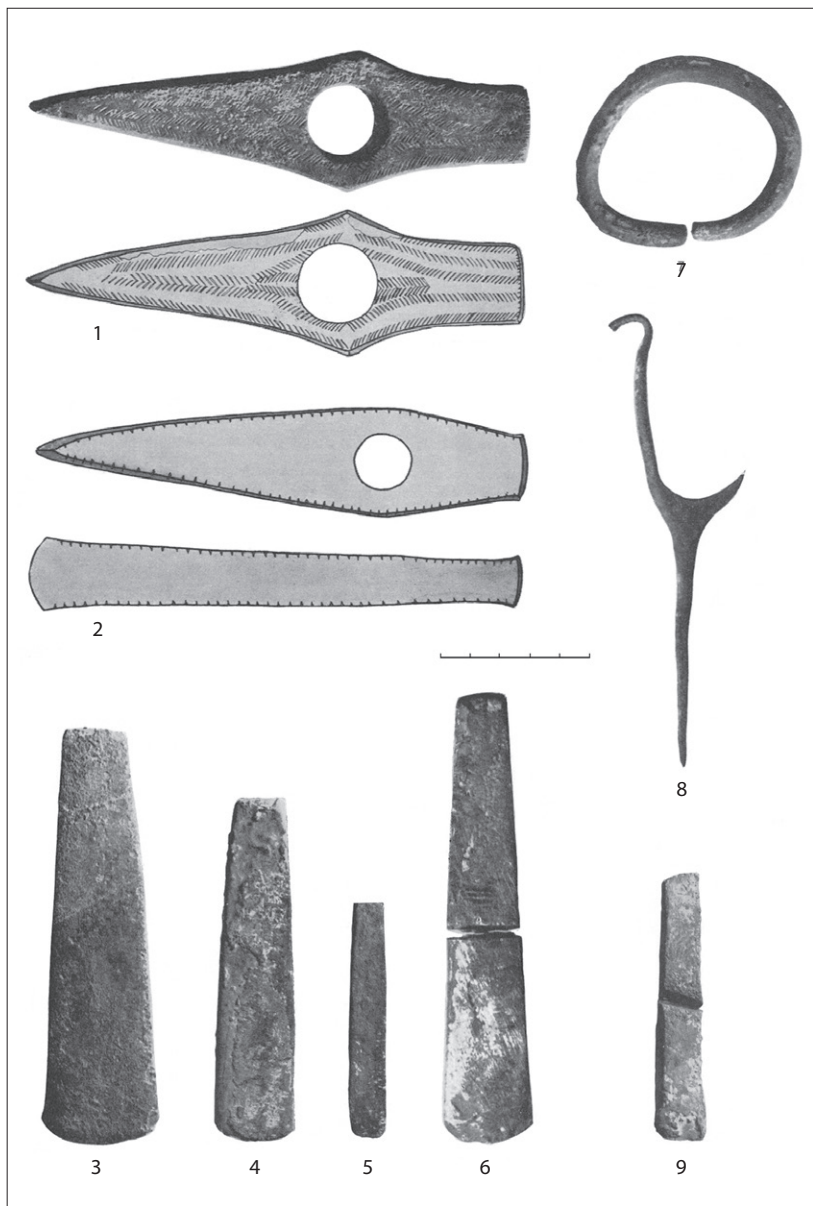

Fig. 3 Pločnik, Serbia. Copper axes from the settlement.

Finds in which both jadeite axes and early products of metallurgy appear together are very rare. Such is the case with the hoard of Großheubach, Kr. Miltenberg, in Lower Franconia. It probably already dates to the 4th millennium BCE³³.

33 Von Haxthausen 1894; Pétrequin *et al.* 2015, 26, Fig. 10 (there incorrectly noted »Kreis Mittelbach« and »Kreis Miltenbach«).

34 Müller 2012, 49. The hoard belongs to the Fuchsberg phase of the Funnel Beaker Culture.

In the 4th millennium BCE the zone of the hoards with metal objects expanded considerably. Thus, the oldest metal objects in northern Germany and southern Scandinavia originate from hoards. Moreover, the first metal hoards were deposited also in the Carpathian Basin, in the northern Black Sea region and south of the Caucasus. In southern Scandinavia, for example, the hoard of Bygholm may have been deposited between 3500 and 3300 BCE³⁴. There the deposition of early metal objects took place parallel to the placement of numerous flint axes together in hoards or individually deposited axes, likewise reaching a peak between 3500 and 3300 BCE³⁵. Many of these flint axes are pure showpieces, which were produced at great expense and effort as ceremonial means of payment in various contexts: one such context was the offering.

The deposition of copper axes also began south of the Alps. In Italy, three axes from the Bocca Lorenza cave are to be mentioned³⁶. A small hoard can probably be dated to the end of the 4th millennium BCE, which was discovered on the right bank of the Ardo River on the 715-m-high Col del Buson near Belluno (Fig. 6). The hoard consists, among other things, of a shaft-hole axe and a flanged axe, both made of pure copper³⁷. They are dated to an advanced stage of the Copper Age by Elodia Bianchin Citton. However, the shape of the shaft-hole axe rather suggests a dating to the last quarter of the 4th millennium BCE. The flanged axe can also be typologically dated to the last third of the 4th millennium BCE. However, similar axes still existed in contexts of the Bell Beaker Culture³⁸.

During the 3rd millennium BCE the deposition of metal objects in the West spread as far as France (Fig. 5) and the Iberian Peninsula. There, various hoards with axes and halberds, as well as numerous single depositions can be connected with the Bell Beaker Culture³⁹.

For the early history of metal deposits several basic features can be recorded. Hatchets and

35 Rech 1979; Wentink 2006; Sørensen/Bjørnevad/Byejensen 2020.

36 Pearce 2007.

37 Bianchin Citton 2013.

38 Artioli *et al.* 2013.

39 Horn 2014; Hansen 2019.

axes dominated single and multiple depositions since the 5th millennium BCE. In the 4th millennium BCE daggers, halberds and short swords were added as advanced products of the metal production. As far as can be estimated, pieces of jewellery such as armrings, neck rings, spectacle spirals, *saltaleoni*, finger rings, etc. remained a rarity in the hoards. Indeed, it is a clear selection of groups of objects, which of course – this should only be noted in passing – cannot be reconciled with the old theories about hidden caches.

In Europe the axe can be followed back to Neolithic settlers. With the use of the axe they cleared forests and built houses. Its symbolic value was undoubtedly high; moreover, it is a widespread phenomenon found in numerous Eurasian cultures that considerable labour went into the production of ceremonial axes⁴⁰.

Two economies in the Bronze Age?

In a programmatic essay, “‘Archival’ and ‘Sacrificial’ Economies in Bronze Age Eurasia”, David Wengrow tried to distinguish two different economies in the second half of the 3rd and early 2nd millennium BCE: “For the first type of system, which I term ‘sacrificial’ (....), we should expect to see clear evidence for the regular and deliberate burial of finished metalwork in copious and impressive quantities, possibly – but not necessarily – in association with human remains and the construction of visible monuments above ground. We should also expect an absence of evidence for systems of information-management based upon the standardisation and authentication of material resources. It is the presence of these kinds of techniques – taking the form of some regular combination of seal impressions, administrative archives, fixed weights and measures, and highly standardised material cultures, including standardised ingot forms of metal – that characterises systems of the second kind, which I term ‘archival’. Since the value of metal within archival systems of management was gen-



Fig. 4 Mainz-Gonsenheim, Federal Republic of Germany. Jadeite axes.

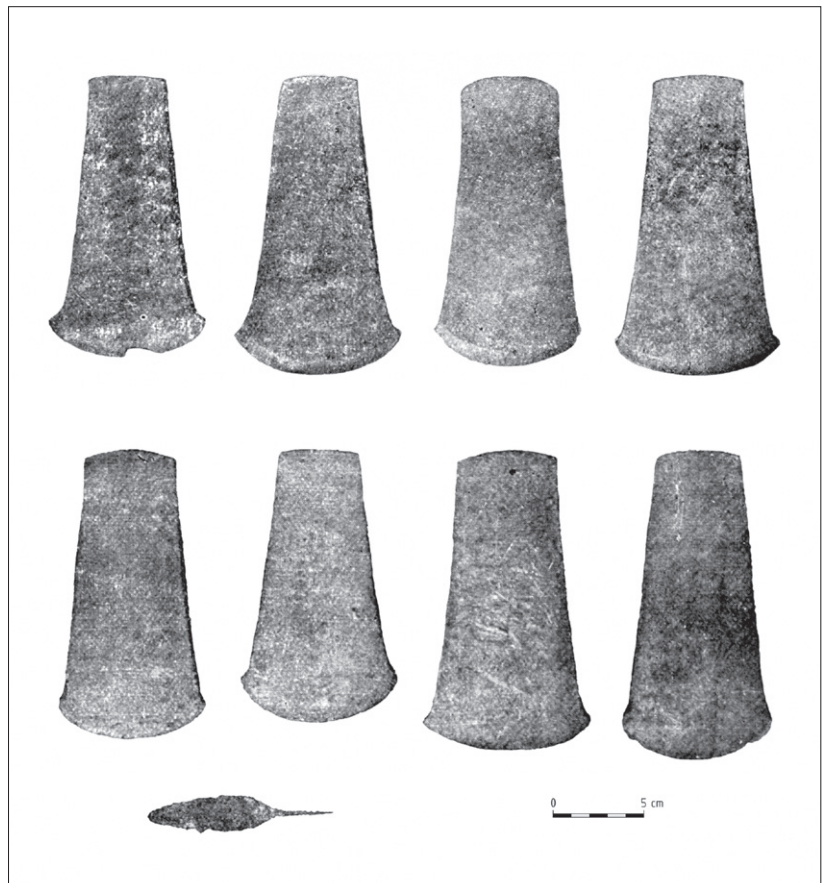

Fig. 5 Trentemoult, dép. Loire-Atlantique, France. Bell Beaker hoard from the Loire.

40 Klimscha 2016.



Fig. 6 Col del Buson near Belluno, Italy. Hoard.

erated by its constant circulation and conversion between different levels of value, we should expect to see a much smaller proportion of metalwork preserved in those parts of the archaeological record where they were dominant, relative to the amounts that were actually in use⁴¹.

In order to be able to systematically describe and distinguish the use of metal in the two postulated economies, a comprehensive source criticism would first be necessary. There are specific reasons for the lack of large quantities of metal in Egypt and Mesopotamia. For example, the widespread robbery of graves in Egypt was aimed particularly at metal objects and reached considerable dimensions⁴². The tomb of Tutankhamen remained the great exception, precisely because it had not been looted. The lack of large metal treasures in temples and sanctuaries in turn is the result of recycling practices, but also of looting, as documented in reliefs and texts⁴³.

That there was metal hoarding in sanctuaries is proven by one of the few preserved finds in Egypt, namely in the temple of Et-Töd near Thebes (Fig. 7). It was a votive offering to Montu, the god of war⁴⁴. Preserved in four copper boxes with the cartouche of Amenemhat II (19th century BCE) were silver ingots and rings, 153 silver vessels folded into small pieces, and numerous beads, amulets and pieces of lapis lazuli⁴⁵.

41 Wengrow 2011, 137.

42 Radwan 1983, 35.

43 This pertains to the Royal Graves, too; for Egypt, see Pinch/Waraksa 2009.

44 Casanova *et al.* 2015.

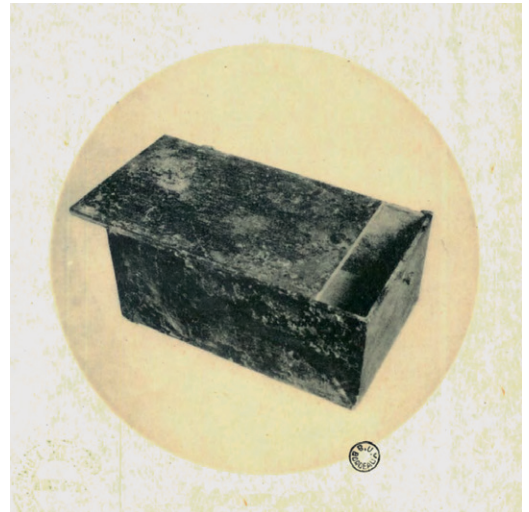

Fig. 7 Et-Töd near Thebes, Egypt. Hoard: copper box.



Fig. 8 Byblos, Lebanon. Hoard Zeta.

Texts as well as finds prove that metal also played an important role in the temples of Mesopotamia⁴⁶. Hoards with copper or bronze objects have been documented in various temples⁴⁷. In addition, there are depots, such as in the Temple

45 Bisson de la Roque/Contenau/Chapouthier 1953; Maran 1987.

46 Evans/Rofßberger 2019.

47 Gries 2019, 144, Fn. 22.

Fig. 9 Byblos, Lebanon. Hoard Zeta.

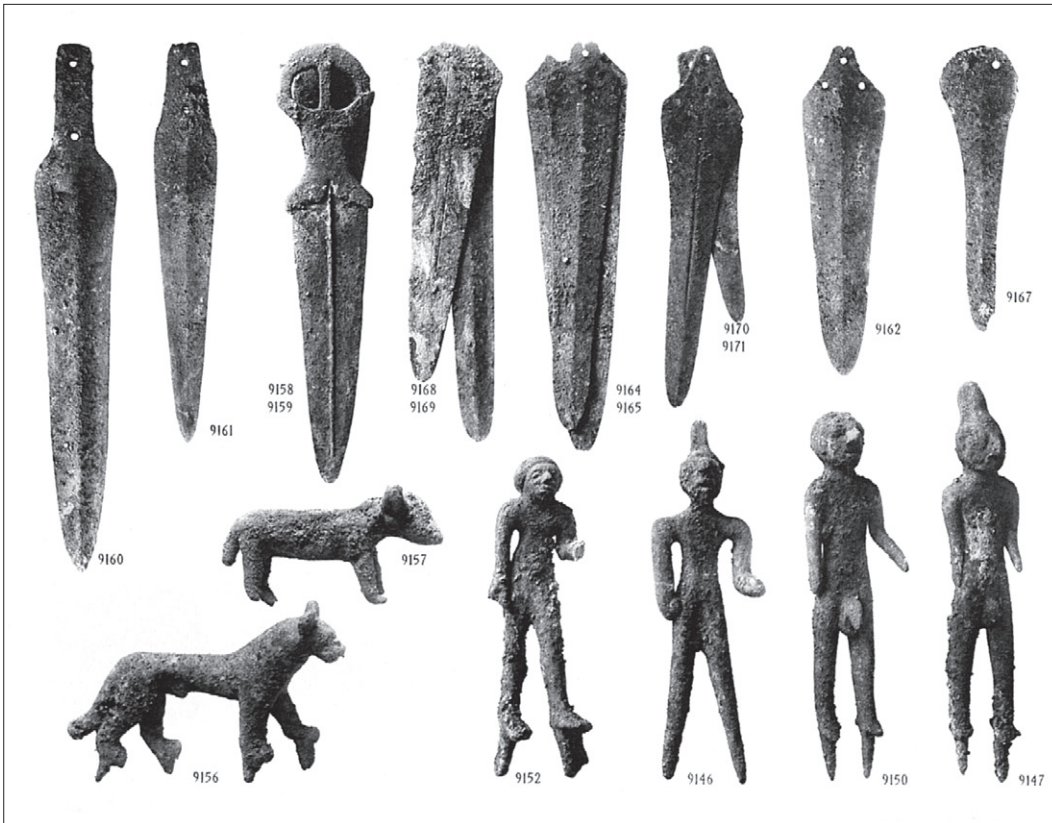

of the Eye in Tell Brak, where numerous metal objects with other valuable materials were deposited⁴⁸. Finally, the depots in the *champs d'offrandes* in Byblos are spectacular (Fig. 8)⁴⁹. Daggers, axes and figures of gods were removed here in large quantities from the metal circulation cycle (Fig. 9). The objects were arranged into “hoards”, and it is obvious that the intention was to document the togetherness of the objects.

If the use of metal in the sacrificial cult were to be properly assessed, all statues and the many metal decorations in the temples would naturally have to be included in an overall account of the metal removed from the cycle⁵⁰. Wengrow himself notes at the end of his remarks that significant exceptions, such as the hoards from Troy or the royal tombs of Ur, are lacking in his explanations. The cost of the tomb furnishings in Ur, in particu-

lar, probably exceeded the furnishings of hoards in Europe during the 3rd millennium BCE by a considerable margin. Grave 755 is taken as an example. In the burial chamber the wooden coffin with the deceased was placed on the north-eastern side⁵¹. The inscription on a golden bowl tells us his name: Mes-kalam-dug, “Hero of the Good Land”. The extraordinarily rich and overly equipped gifts included a golden “helmet”, a golden lamp, 6 gold and 14 silver vessels. In the coffin there was a double axe made of electrum (Fig. 10) and a dagger with a golden blade as well as a whetstone made of lapis lazuli⁵². Several axes and five bronze daggers with silver and gold handles had been placed outside the coffin.

The numerous metal gifts of the “Royal Tomb” in Arslantepe and the tombs of Bashur Höyük are older than the royal tombs of Ur⁵³.

48 Mallowan 1947.

49 Dunand 1950; Dunand 1954.

50 For example, the statue of Pepi II, in Hierankopolis (Quibell/Green 1902).

51 Woolley 1934.

52 Hansen 2002.

53 Sağlamlıtimur/Massimino 2018.

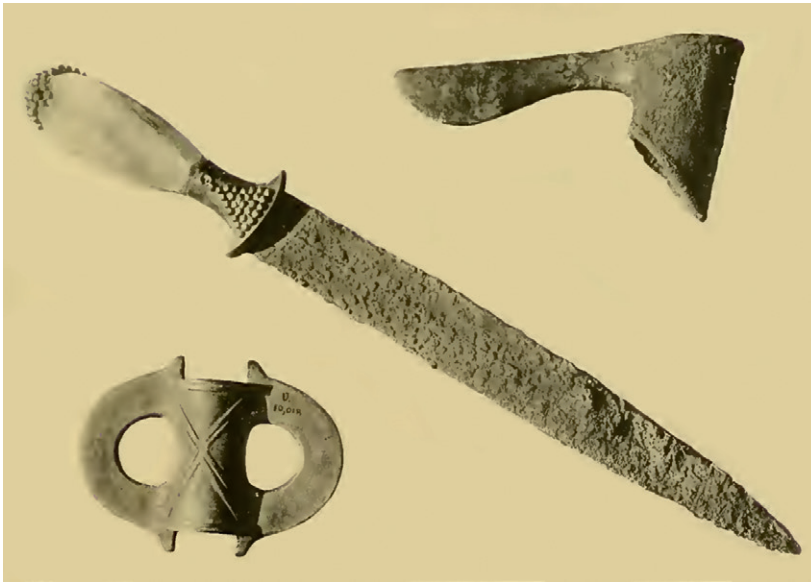

Fig. 10 Ur, Iraq, Grave 755: axe made of electrum.

Haluk Sağlamtimur and Martina Massimino also refer to Wengrow when comparing the contrast between the overly rich funerary furnishings in the Early Bronze Age tombs of Bashur Höyük with the previous period of the so-called Uruk expansion. They state that the metal in Bashur Höyük was sacrificial, whereas in the archival-based economies it is a commodity that remained in circulation.

However, two aspects become apparent here, which do not suggest an “either or”, but a “both and”. On the one hand, in the state societies between the Euphrates and Tigris rivers and on the Nile, as already indicated, metal was also taken in large quantities out of circulation for sacrificial purposes and conveyed to the deities. On the other hand, in the non-state societies of Europe in the 3rd and early 2nd millennium BCE, metal objects were not only used for sacrificial purposes, but also as everyday objects, commodities and goods. In the hoards and graves, metal was generally deposited “sparingly”. Even in the

graves of those who identified themselves as rulers by adding a sword, i.e. the most technically advanced means of violence, there were only small amounts of metal added. Here – just as in the hoards – a supra-regional standard equipment is recognizable⁵⁴. “Thrifty”, “small quantities” and “waste” are of course vague terms, the current use of which, moreover, arose in a specific religious and intellectual discourse that belongs to the basic principles of Calvin’s Protestantism. However, it was concretized in the mass poverty of the late 18th and 19th centuries AD, which was scandalized by Marx and other theorists⁵⁵. It was during this period that savings banks were founded to enable the lower classes to build up financial reserves⁵⁶. This was the opposite of the wastefulness of luxury goods of colonial origin ostentatiously displayed by the rich, which then became the subject of well-known sociological analyses by Torstein Veblen or Werner Sombart at the end of the 19th century⁵⁷.

Yet, in this theoretical framework alone, the depositing of bronze cannot be adequately explained. Furthermore, the terms would also have to be clarified by an economic analysis of the value. The value of bronze and gold in the Bronze Age remains an unknown and arbitrary quantity as long as it is not embedded in an overall economic analysis. The value of an object can best be set on a level comparable to other goods or commodities by determining the amount of time needed to extract and to produce it.

Unfortunately, reliable statements on the amount of metal deposited in hoards are currently not possible and remain a research desideratum. The amount of metal in circulation must have been considerable, if one takes the estimates of the mining volumes of copper-ore extraction in the Alps or other mining areas as a basis⁵⁸. A certain idea can be gained from the sunken ship of Ulu Burun on the south coast of Turkey,

54 Hansen 2016.

55 Marx 1844, 547: »Die *Quantität* des Geldes wird immer mehr seine einzige *mächtige* Eigenschaft; wie es alles Wesen auf seine Abstraktion reduziert, so reduziert es sich in seiner eignen Bewegung als *quantitatives* Wesen. Die *Maßlosigkeit* und *Unmäßigkeit* wird sein wahres Maß«. – “The quantity of money becomes to an ever greater degree its sole effective quality. Just as it reduces

everything to its abstract form, so it reduces itself in the course of its own movement to quantitative being. Excess and intemperance come to be its true norm” (englische Übersetzung in <https://www.marxists.org/archive/marx/works/1844/manuscripts/capital.htm>).

56 Muschalla 2018.

57 Veblen 1994; Sombart 1996.

58 Stöllner *et al.* 2006.

which was loaded with ten tonnes of copper and one ton of tin. The ship sank in the 14th century BCE and was certainly only one among dozens of such ships. Thus, eleven tons of bronze could have been produced with this shipload and about 22,000 swords could have been cast. No one has weighed all of the hoards of Europe. But these are mainly very small find ensembles under 20 kg in weight. With the intentional destruction of the gifts and the deposition of fragments, a much more “economical” use of the metal was also possible in the Late Bronze Age, because the majority of the objects returned to the cycle. Thus, the weight of the metal in these hoards is likely equal to, or not significantly greater than, the shipload of Ulu Burun at eleven tons⁵⁹. Even if the weight of the hoards were equal to two shiploads, it is difficult to speak of a “sacrificial economy” in relation to the hoards.

Let us note this: metal was also sacrificed in the “archival” economies, and in the “sacrificial” economies the metal was usually kept in circulation.

The logic of the votive offerings

The mystery of the supposedly two different economies is solved to some extent, if one looks at the meaning behind the deposited bronze objects in the perspective of the ‘gift’. In his “*Essai sur le don*”, published in 1924, the French ethnologist Marcel Mauss, a nephew of Émile Durkheim, drew attention to a hitherto neglected social institution: the exchange of gifts. In depicting this institution, which was as “mysterious as it was beautiful”, Mauss attempted to present a counter-image to the crisis-ridden conditions in France, namely a society founded upon altruism and generosity: “It is important that (...) the rich (voluntarily or by force) should again come to regard themselves as the treasurers of their fellow citizens, so to speak”⁶⁰. Mauss opened up a whole new perspective on the discourse of waste-fulness. In the exchange of gifts, waste is not a

mechanism of egoism (as in modern Europe), but of selflessness. The contemporary discourse thus underwent a surprising turnaround. In this respect “The Gift” is not a purely academic text. As a member of the socialist *Section française de l'internationale ouvrière*, Mauss examined the value of this unknown institution for the present day, and, not least for this reason, he examined the traces of this institution in the old legal and economic systems of Europe.

The giver and the receiver were subject to the contractual norms of the “give-take-return” procedure. Using ethnographic material, in particular the Melanesian Kula, Mauss worked out that the archaic exchange was apparently voluntary, but in fact it based upon three obligations: namely to give, to take and to return. The one who wants to gain prestige is obliged to give. The recipient must accept the gift, if he does not wish to lose face. He is thus obliged to reciprocate the gift. This results in a constant movement of goods between the exchange partners, which ultimately serves social cohesion. Archaic exchange is an institution in which all sections of society are interwoven; everything is mixed here.

The objects exchanged are vehicles of social bonding between the participants of the exchange. Mauss realised that the exchanged objects are not treated as mere objects, but as objects with a soul, and that the exchanged objects are thus never completely detached from their previous owners. For Mauss the exchange was the starting point for the networking and sociality of every society. Societies that do not exchange are practically inconceivable. Claude Lévi-Strauss emphasised this in the “elementary structures of kinship” by speaking of the “basic complex of culture”⁶¹.

Mauss also included the exchange with the imaginary powers and remarked in connection with the potlatch that the spirits of the dead and the gods were “the true owners of the things and goods of the world”⁶². He further emphasized: “With them (the spirits and the gods, S.H.) exchange was most necessary and non-exchange

59 Catalogue Bochum 2005.

60 Mauss 1968, 162.

61 Lévi-Strauss 1981a, 107–127, here 119.

62 Mauss 1968, 43.

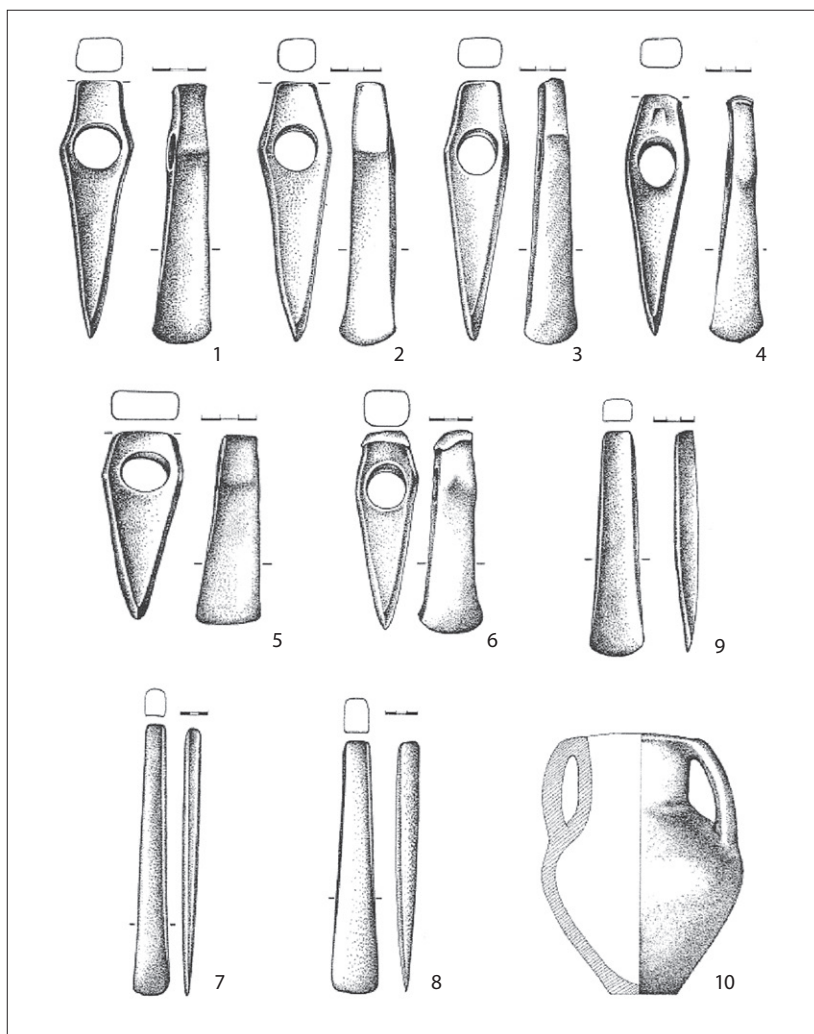

Fig. 11 Rakilovci, obl. Radomir, Bulgaria. Hoard with hammer axes.

most dangerous. On the other hand, with them it was also the easiest and safest⁶³. Votive offerings are basically a special kind of sacrifice⁶⁴. The sacrifice is a mediator between the gift-giving person and the deity, and prevents the imaginary powers from seizing the person himself. Henri Hubert and Marcel Mauss, however, wanted the term “sacrifice” to be reserved for the bloody sacrifices, even though the destruction of the votive offering is, strictly speaking, also a sacrifice⁶⁵. But for them the bloody sacrifice was another form of “seriousness”.

63 Mauss 1968, 43.

64 Mauss 2012, 97–216.

65 Hubert/Mauss 1968.

66 Godelier 1999, 21–22.

The gifts to the gods and spirits are to be understood as a return for the goods they received. The mechanism of the transaction between humans and gods corresponds in essential features to the exchange mechanisms between the earthly humans. In fact, this mechanism is not necessarily reciprocal, but very competitive. For those persons who are in possession of many earthly goods could, as it were, establish exclusive relationships with the imaginary powers. By offering valuable gifts, they could expect correspondingly large counter-gifts and thus accelerate the dynamics of social inequality⁶⁶.

The gift as an institution was common in Bronze Age class societies and, as can be seen in diplomatic correspondence, it was extensively cultivated among the royal centres in the Eastern Mediterranean region⁶⁷. The basic principles of exchange with the imaginary powers and the deprivation of values for ritual purposes, however, certainly followed rules of reciprocity, which had been developed long before metal was used⁶⁸.

Hoard and graves with axes during the 5th millennium BCE in the Carpathians and the Caucasus

As mentioned above, the practice of metal deposition in Southeastern Europe can be traced back to the early 5th millennium BCE, where axes were deposited in large numbers and with considerable weights. For example, the hoard of Rakilovci, obl. Radomir, in western Bulgaria contained axes (Fig. 11, 1–6) with a total weight of over 6 kg⁶⁹. The thus far largest hoard of the Copper Age was found recently in Polkovnik Taslakovo, obl. Duloovo, in the Bulgarian Dobrudzha. It contained 18 flat axes and 4 hammer axes with a total weight of 11.6 kg⁷⁰.

However, there is a clear regional variation in the manner of deposition in the Carpathian Basin. In the Hungarian lowlands there are cemeteries of the Tiszapolgár and Bodrogkeresztúr

67 Knudtzon 1915; Cochavi-Rainey 1999; Kelder 2009.

68 Nakassis/Galaty/Parkinson 2016.

69 Michailov 2008, 35 ff., Figs. 1–8.

70 Chernakov 2018.

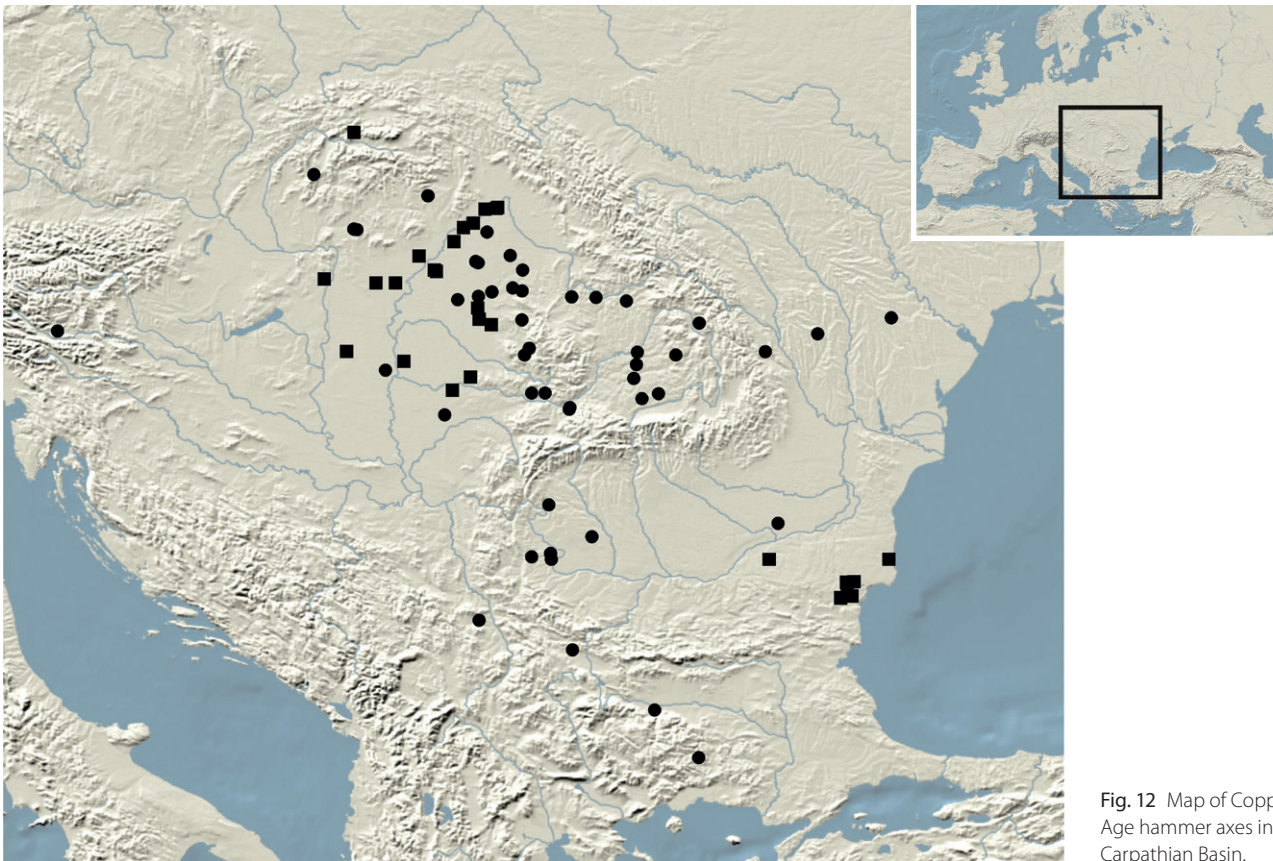

Fig. 12 Map of Copper Age hammer axes in the Carpathian Basin.

cultures, in which axes were used as grave goods in burials of the highest social group. In the eastern Carpathian Basin, however, axes were deposited exclusively in hoards or as single depositions (Fig. 12). Here we encounter two different social practices.

This has consequences for the dating of the axes, to which we will return here several times. The axe-adzes of the Jaszladány type associated with the Bodrogkeresztúr Culture were long dated to the early 4th millennium BCE. With the re-dating of Bodrogkeresztúr to the last third of the 5th millennium BCE, the axes have also moved in time⁷¹. In his doctoral thesis Sven Brummack shows that in the cemetery of Rákóczifalva-Bagiföld axes were found in the section of older graves, while in the younger section daggers were found in graves⁷². The ad-

dition of daggers also continues in graves of the 4th millennium BCE⁷³. This presents archaeology with the challenge of how to interpret the resulting gap in the 4th millennium BCE, in which no dated find contexts with axes are known.

East of the Carpathians, several hoards of the Cucuteni-Tripolye Culture on both sides of the Dniester River are known from this period. The hoard of Cărbuna, raion Ialoveni in the Republic of Moldova, is probably one of the oldest depositions⁷⁴. It contains 851 objects. Aside from a copper and a stone axe, there are numerous copper pendants, spondylus beads and appliques, and numerous upper canine teeth of the red deer. The hammer axe of the type Pločnik was probably made between 4700 and 4300 BCE⁷⁵.

In the hoard of Brad, jud. Bacău in the Romanian Moldavia, 2 copper arm rings, a copper axe

71 Csányi/Raczký/Tárnoki 2010; Sava 2015.

72 Brummack in preparation.

73 Šiška 1972.

74 Sergeev 1963; Dergachev 1998; Beldiman/Sztancs 2000–2006.

75 Diaconescu 2014.

Fig. 13 Brad, jud. Bacău, Romania. Copper axe.

Fig. 14 Location unknown, probably Dniester region. Hoard.



Fig. 15 Ovçular Tepesi, Nakhchevan, Azerbaijan. Child's grave with copper axe.

(Fig. 13), 2 small gold discs, 262 copper beads, 15 beads of a “glass” mass, 190 deer canines and 2 marble beads were found⁷⁶. The axe from Brad likely dates to the last third of the 5th millennium BCE. Dergachev recently published seven hoards that circulated in the internet or antiquities trade⁷⁷. With these detector finds, the number of known hoards of the Cucuteni-Tripolye Culture has nearly doubled to 15. Concerned here are mostly hoards containing one or two axes and a variety of small jewellery such as *tutuli*, beads and rings. Also noteworthy is a hoard (Fig. 14) of unknown origin, probably from the middle Dniester region, with an axe similar to the one in the hoard of Brad and a flat axe, which can also be dated to the late 5th millennium BCE⁷⁸.

In the Caucasus, the oldest dated copper axe (Fig. 15 above) comes from a child's grave in Ovçular Tepesi (Nakhchevan) and is dated to the last quarter of the 5th millennium BCE⁷⁹. The axe represents the same type as the axe in the aforementioned hoard from an unknown site (Fig. 14).

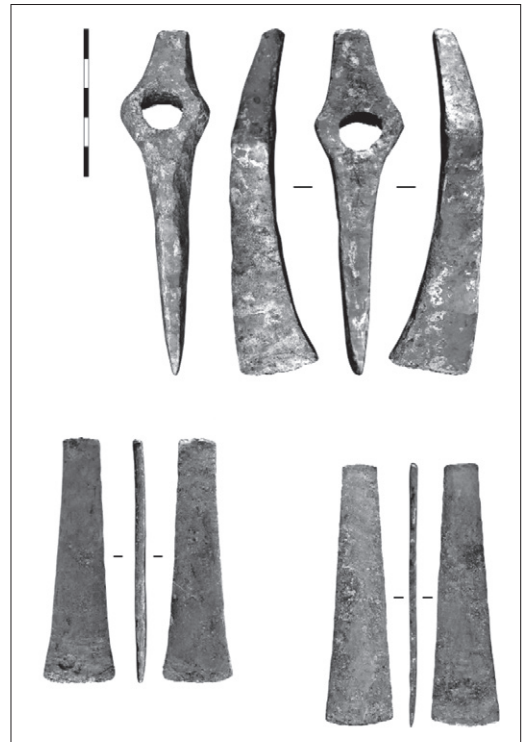

76 Ursachi 2012.

77 Dergachev 2016.

78 Dergachev 2016, Pl. 3,2.

79 Marro/Bakhshaliyev/Ashurov 2011, 70 note that the

child “had an outstanding social status, a status evidently linked to birth and not to function”. For the 550 g hammer axe and the two flat axes, see Marro/Bakhshaliyev/Ashurov 2011, Pl. 10.

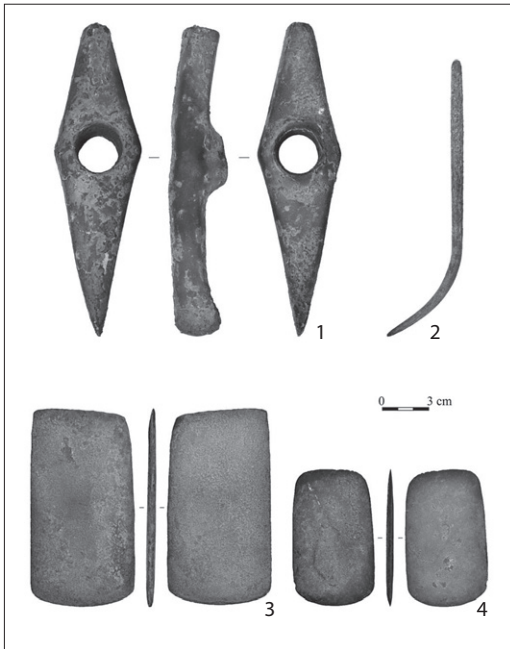

Hoard of the first half of the 4th millennium BCE

In the Carpathian Basin the dilemma of dating not only concerns the axe-adzes of the type Jaszladány, but also of the Székely-Nádudvar type⁸⁰. Of the more than 130 known axes of this type, not a single specimen comes from a grave. For the 4th millennium BCE, as already mentioned, there is no datable find complex available in the Carpathian Basin. We can only assume that some of the hoards with a single or several objects were deposited in the early 4th millennium BCE. This assumption might also be supported by finds, in which flat axes of the Szakálhat type are represented⁸¹. However, these are already associated with gold discs of the type Tenja in the hoard of Stollhof, which was probably created in the last two centuries of the 5th millennium BCE⁸². It is clear that a stable chronology cannot be established with these hoards and that only grave finds or scientific datings can help at this point.

80 Pop 2007.

81 Gleirscher 2007.

82 Hansen 2014.



Also east of the Carpathians the practice of deposition continued. On the southeastern edge of the Carpathians, a small hoard with a hammer axe (*Fig. 16,1*), two flat axes (*Fig. 16,3–4*) and an awl (*Fig. 16,2*) was deposited in a prominent height in Dobrileşti, jud. Buzău⁸³. The hammer axe dates to the late 5th or early 4th millennium BCE; the flat axes are not significant for the dating. The hoard of Vinnitsya (Vinnicja) in Podolia (*Fig. 17*) was also deposited during this period. It was placed in a biconical vessel of phase B2–C1 of the Tripolye Culture. The vessel contained at least 20 spiral temple rings (*Fig. 17,32–51*), 13 of them probably made of silver, and beads of copper and of bone or spondylus⁸⁴. The spiral rings are an indicator of high social rank and are only found in pairs, at most in graves with above-average furnishings. Thus, the deposition of 20 such rings corresponds to 10 high-class grave furnishings. This illustrates the social significance of the hoards. However, the find pattern is by no means stable. The example of the Tripolye hoard shows how quickly the

Fig. 16 Dobrileşti, jud. Buzău, Romania. Hoard.

Fig. 17 Vinnitsya, Ukraine. Hoard.

83 Munteanu/Costache 2016 date the hoard to the late 4th or early 3rd millennium BCE.

84 Dergačev 2016, 191, Pl. 5. The find derives from the antiquities market.

Fig. 18 Radjanski, obl. Vovtschans'k (Wolchanski), Ukraine. Hoard.



Fig. 19 Staromyshastovskaya, krai Krasnodar, Russian Federation. Hoard.

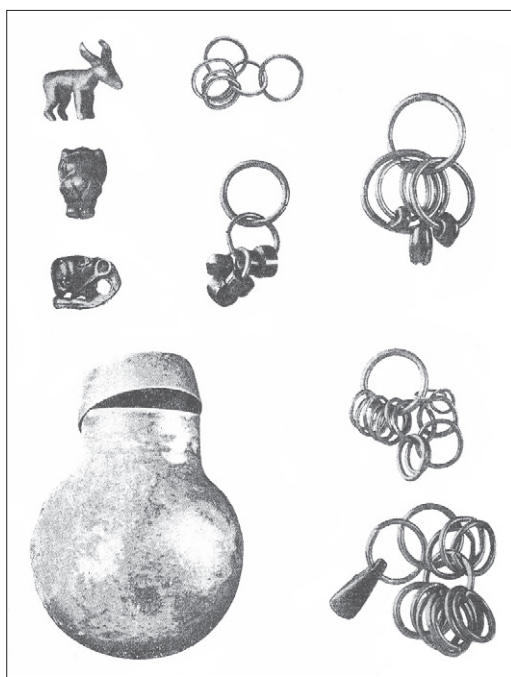

It is the find of Staromyshastovskaya (Fig. 19), which was discovered in 1897 during clay extraction. This hoard comprised a silver vessel with a lid, inside of which were, among other things, a small golden lion's head, 2549 gold, silver, carnelian and lapis lazuli beads, gold rings with carnelian beads, the silver figure of an antelope(?) and numerous interlocking rings⁸⁶. Several carnelian beads have the shape of an axe. The hoard has also been considered a possible burial site, but the find situation speaks against this assumption⁸⁷.

In the South Caucasus, the find of Dzhrashen near Yerevan with seven spiked axes (Fig. 20,1–7), ten slender flat axes (Fig. 20,8–17) and one shaft-hole axe (Fig. 20,18) is currently the largest and oldest multi-piece hoard⁸⁸. Three further spiked axes are known as single finds from Georgia⁸⁹. For the time being, it remains to be seen whether these axes must be regarded as the remains of destroyed hoards or graves, or whether they are individually deposited axes. They are certainly not accidental losses.

Far away from the Caucasus, in Sé Girdan on Lake Urmia, six of eleven burial mounds had been partially excavated by 1970. The looted mound IV still contained three axes and a flat axe as well as 565 gold and 38 carnelian beads. The burial chamber was built with carefully layered stone slabs⁹⁰. Unfortunately, the chronological assignment of the graves cannot be based on

number of finds can be multiplied many times over through finds made metal detectors. Thus, the find of 10 flat axes (Fig. 18), allegedly from Radjanski, is a big surprise and cannot yet be assigned a find pattern. It is attributed to the Sredni Stog Culture by Viktor I. Klochko and Anatoli V. Kozymenko⁸⁵.

In the North Caucasus, only one hoard from the 4th millennium BCE has been found so far.

85 Klochko/Kozymenko 2017, 10, Fig. 18.

86 Tallgren 1928, 389; Korenevskii 2004. Colour illustrations are found between pages 80 and 81.

87 Tallgren 1928, 389; Munchaev 1975, 225.

88 Chernykh 1992, 64–65, Fig. 21; see also Korenevskii 2011, 65–67, Pls. 47–49; Helwing 2017; Hansen 2020, 181–184.

89 Gambashidze *et al.* 2010, 328 ff. Nos. 246 (Tiflis); 249 (Pinezauri gorge) and 250 (Dmanisi), Pl. 16,246.249.250. Finds from Armenia in Korenevskii 2011, 247, Figs. 48,2 (Alaverdi); 48,5 (Ajrum).

90 Muscarella 1971, 7–14.

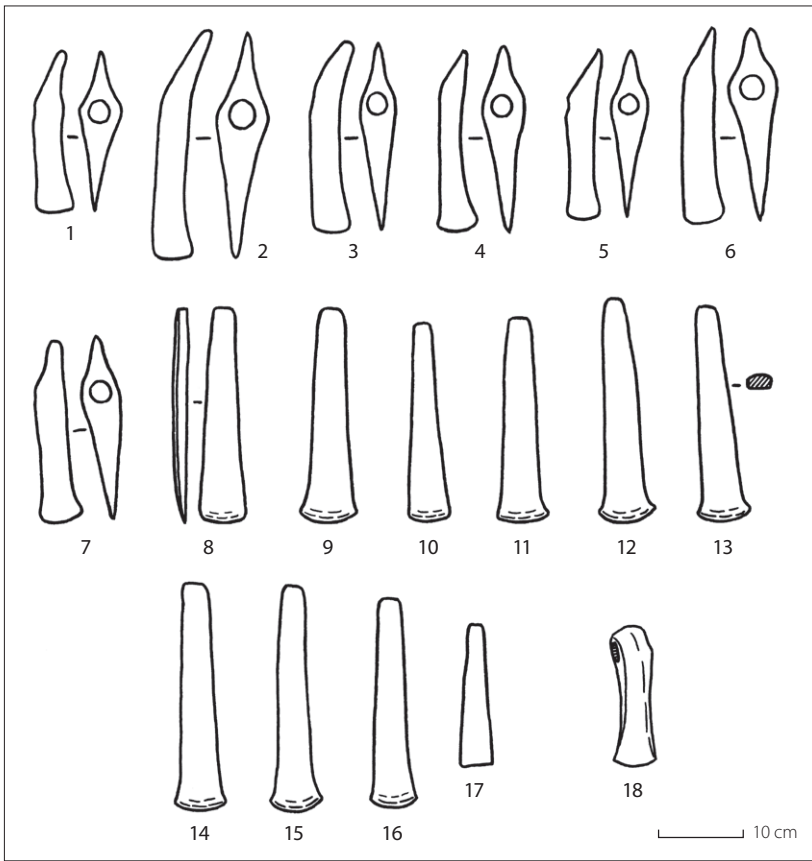

Fig. 21 Verem'e, obl. Kiev, Ukraine. Spiked axe.

Fig. 20 Dzhrashen near Yerevan, Armenia. Hoard.

14C dates, but the grave goods – especially the silver vessel – in tumulus III suggest a dating to the first half of the 4th millennium BCE⁹¹.

This dating is supported by an axe (Fig. 21) from Verem'e, raion Obukhov in the Dnieper region, because it was found in a settlement of the Tripolye B2 phase and can therefore be dated to the first quarter of the 4th millennium BCE⁹². Both Chernykh and Dergachev identified this axe as a Caucasian import⁹³. Thus, the axes with a spiked neck can be described as a type of implement widespread in the Caucasus (Fig. 23), which occasionally reached the area of the Tripolye Culture. An axe of this form comes from grave 5 in Lechinkaï kurgan 7 (Fig. 22) and another specimen from Pyatigorsk in the Northern Caucasus⁹⁴.

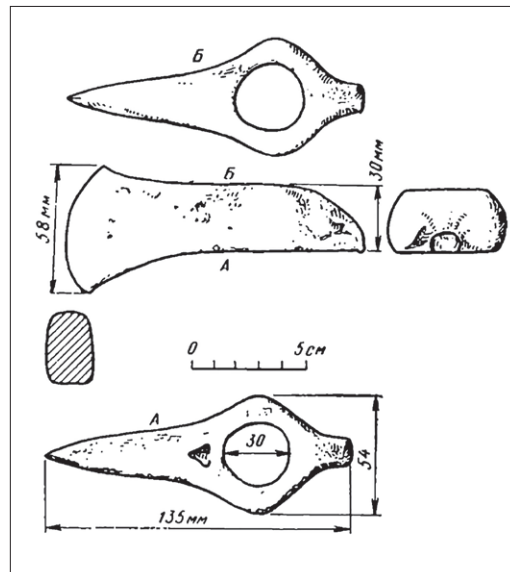

Fig. 22 Lechinkaï, krai Stavropol, Russian Federation. Kurgan 7, tomb 5: spiked axe.

91 Hansen 2020, 184.

92 For the chronology, see Müller *et al.* 2016, 165, Fig. 4.

93 Chernykh 1992, 64; Dergachev 2002, 58, 193 No. A15,

Taf. 57, A15; photograph of the axe in Korenevskii 2011, Pl. 48,4.

94 Korenevskii 2011, 246, Fig. 47,1–2.

Fig. 23 Distribution of spiked axes between Caucasus and Carpathians.

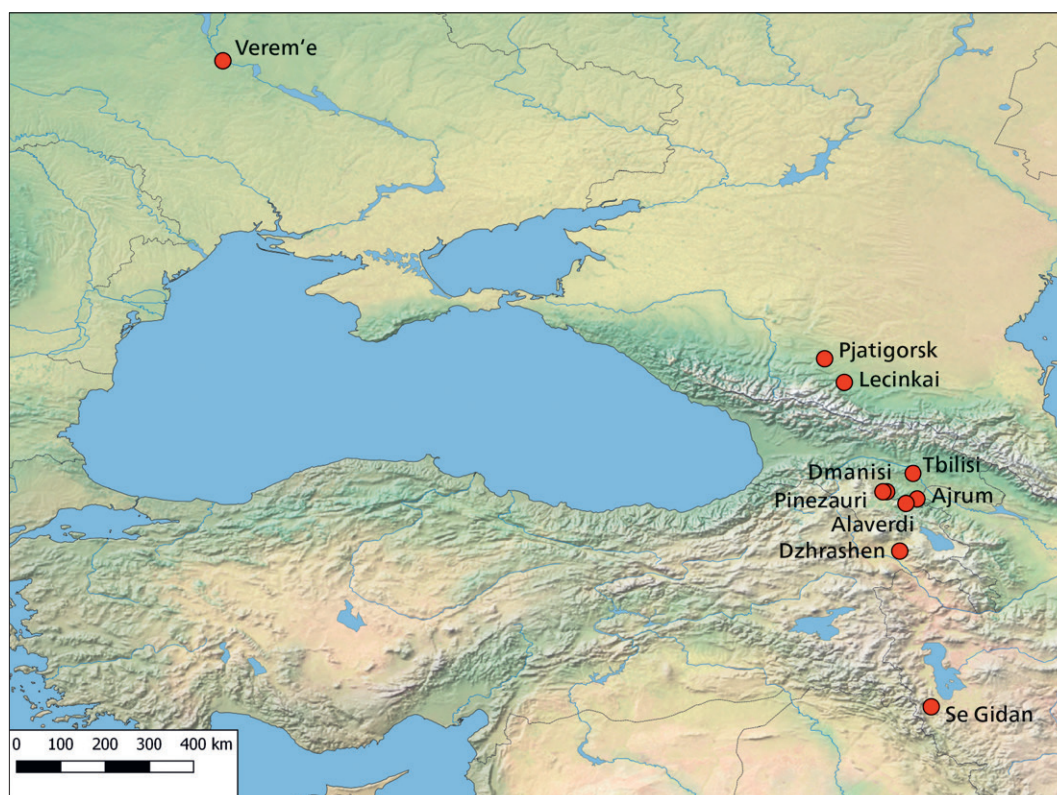

Axes in graves dated between 3700 and 3000 BCE

In the North Caucasus, metal finds are known almost exclusively from graves. One of the earliest complexes is the eponymous tomb of Maikop⁹⁵. Whereas it was long dated to the 3rd millennium BCE, today there is a wide consensus that it was built before the middle of the 4th millennium BCE. The deceased was given a functional set of arsenic bronze tools. These are a shaft-hole axe (Fig. 24,1), a small and a large dagger (Fig. 24,2–3), an axe-adze (Fig. 24,4), an adze (Fig. 24,5), two flat axes (Fig. 24,6–7) and two gouges (Fig. 24,8–9). We do not find such a “toolbox” in any other find complex of the 4th millennium BCE, and this also underlines the great importance of the tomb.

The shaft-hole axe is thus the oldest example of this type of tool that has been found in a closed find context. However, it has been questioned whether the axe form was developed in the Caucasus and whether the specimen from Maikop is indeed the oldest. Marija Ivanova, for example, claims that the “probable area of origin” of the shaft-hole axe lies “in the Iranian-Central Asian region”⁹⁶. However, this cannot be proven by corresponding finds. In fact, the evidence from Balochistan cited by Ivanova should be dated much later. The two axes and the adze from room CXXVI (layer III,6) in Afghanian Mundigak (Fig. 25) belong to the end of the 4th or the beginning of the 3rd millennium BCE⁹⁷. This is also confirmed by the recently published, very well equipped grave with 125 pottery vessels found in Spidej in Iranian Baluchistan, in which two

95 Now comprehensive with older literature: Piotrovskij 2020.

96 Ivanova 2016. Cp. already Helwing 2004, 12.

97 Casal 1961, 249, Pl. 39B.

shaft-hole axes with a slightly trapezoidal form were found⁹⁸. The excavators date the find ensemble to around 3000 BCE (3200–2800 BCE). Another axe was found by Aurel Stein in the rich tomb VIIB of Shahi Tump and already published in 1931⁹⁹. The cemetery of Shahi Tump is currently being dated to the period IIIa-Phase 2, i.e. in the last third of the 4th millennium and the beginning of the 3rd millennium BCE¹⁰⁰. The fragment of a casting mould from Böyük Kesik (Azerbaijan) cited by Ivanova belongs to the second quarter of the 4th millennium BCE and, therefore, is by no means older than the tomb in Maikop. The axes cited by Ivanova as “probably from southern Mesopotamia”¹⁰¹, and from Susa are not stratified and, therefore, must also be excluded in the argumentation about possible predecessors¹⁰². Thus, at best, a “hypothetical axe 0” can be assumed in Iran or Central Asia.

As long as such precursors of Caucasian shaft-hole axes cannot be proven or made plausible, the Caucasus can be identified as the region where the innovative shaft-hole axe was developed. The “dated axe 0” comes from the North Caucasus. However, all regions in which the entire metallurgical chain – from the mining of ore to metal casting – was dominant at an early stage, were at least indirectly in contact from the beginning. Otherwise, the parallel occurrence of certain techniques, such as alloying, casting in the lost wax form or the use of technical ceramics between Southeast Europe and the Iranian highlands can hardly be explained. As the example of the axes with spiked neck demonstrates, the Caucasus was already integrated in a much larger network of technology in the early 4th millennium BCE, reaching from the Carpathian Basin to Iran.

All objects in the toolbox of the Maikop kurgan could have been technically realized much earlier. Here the innovative step from the spiked axe to the shaft-hole axe of the Maikop type was very small, and this also speaks in favour of the fact that the shaft-hole axe was also developed

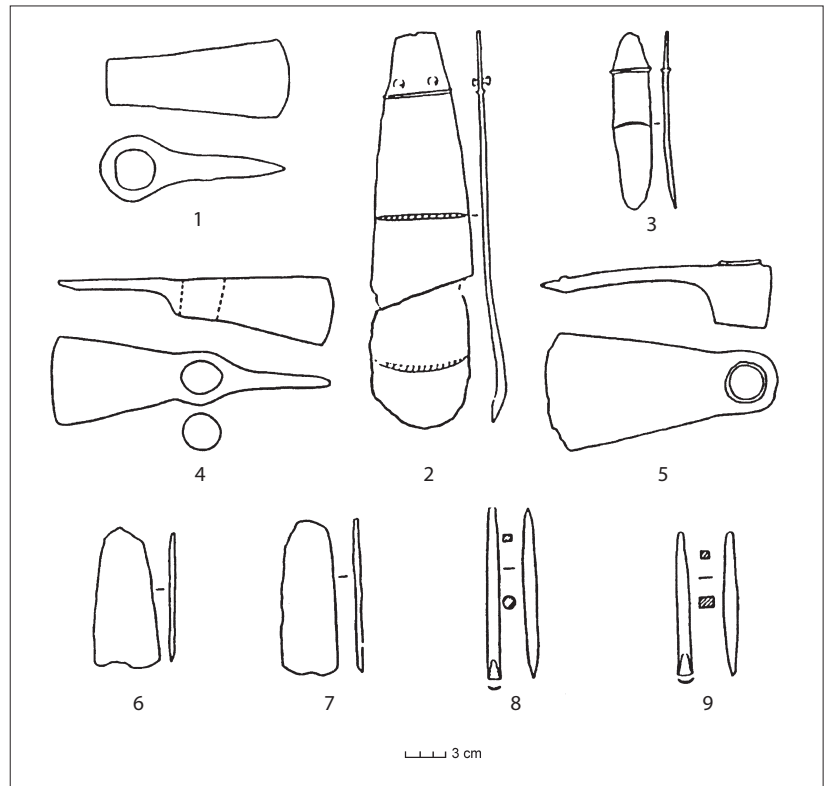

in this area. Gernez refers to a “zone of conceptual and technical innovation” with regard to the development of weapons from the Caucasus, including eastern Anatolia¹⁰³.

The search for the origin of the shaft-hole axe is obviously also an expression of different concepts of cultural development. The prevailing

Fig. 24 Maikop, Adygea, Russian Federation. Kurgan (“Oshad”): set of tools.

Fig. 25 Mundigak, Aghanistan. Axes and adze from room CXXVI.

98 Heidary/Desset/Vidale 2019.

99 Stein 1931, 95–96, Pl. 13,135; Piggott 1950, 219, Fig. 26.

100 Didier/Mutin 2013, 465–470.

101 Müller-Karpe 2002, 138, Fig. 2.

102 Tallon 1987, No. 71.

103 Gernez 2017, 43.

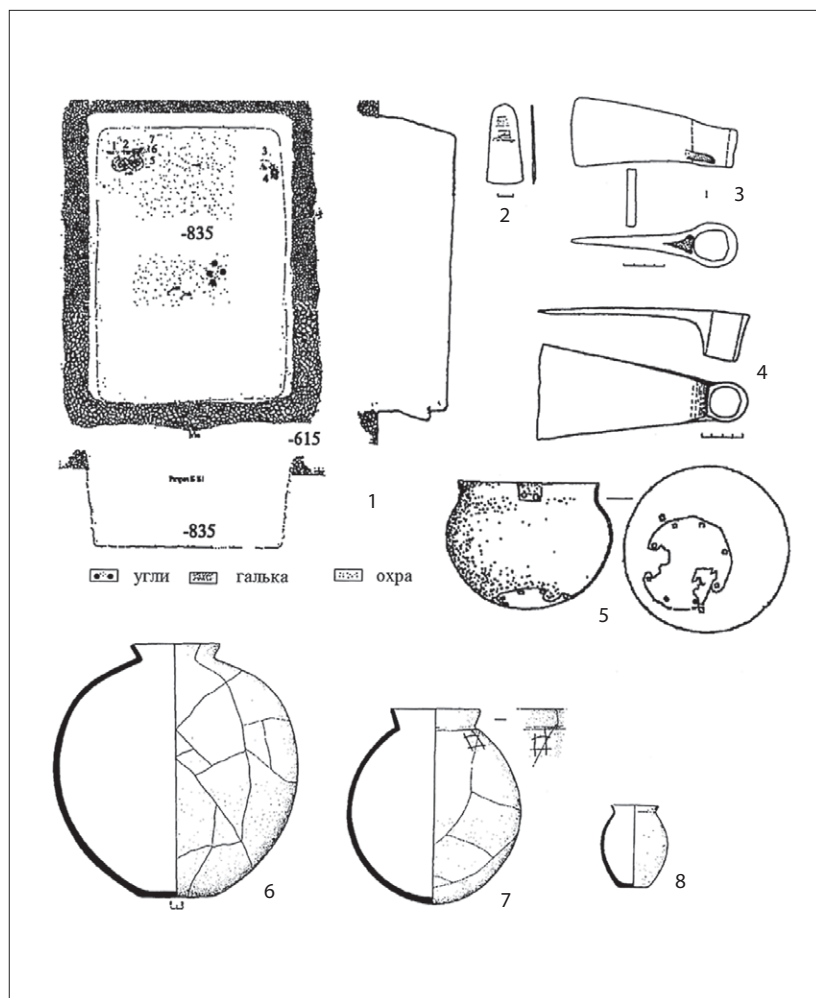

Fig. 26 Zamankul, North Ossetia, Russian Federation. Grave goods.

Fig. 27 Nal'chik, Kabardino-Balkaria, Russian Federation. The two axes from the great kurgan.

Fig. 28 Chegem II, Kabardino-Balkaria, Russian Federation. Kurgan 21, tomb 4: axes.

view that the Maikop phenomenon emerged under the influence of the Uruk expansion is often based not only on the *ex oriente lux*-paradigm, but also on questionable chronological equations¹⁰⁴.

In the North Caucasus there are a number of other grave complexes that continued with shaft-hole axes. In grave 70 of the 6.5-m high kurgan 1 near Zamankul in North Ossetia the remains of a 40 to 45-years old man and a 20 to 25-years old woman were found¹⁰⁵. The grave goods include a bronze adze (Fig. 26,4), a flat axe (Fig. 26,2), a shaft-hole axe (Fig. 26,3), a bronze vessel

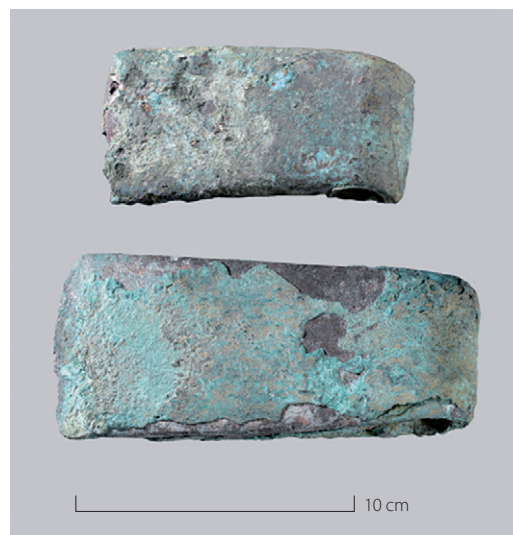

(Fig. 26,5) and three clay vessels (Fig. 26, 6–8). According to the 14C date, the grave could also have been emplaced before the middle of the 4th millennium BCE.

With slight variations, the shape of the axes remained relatively the same until the end of the 4th millennium BCE, as the two shaft-hole axes from the great kurgan of Nal'chik (Fig. 27) show, which, according to a 14C date, might belong to the 30th century BCE¹⁰⁶.

Due to the lack of 14C dates, it is therefore not possible at present to determine the age of the axes from several other graves in the vicinity

104 Helwing 2017, 53.

105 Korenevskii/Rostunov 2004; Ryndina/Ravich 2019, 94, Fig. 24,123, Fig. 37,2239.

106 Chechenov 1973; Belinskij/Hansen/Reinhold 2017.

of Nal'chik with any degree of accuracy. Further, axes were used as funerary objects for two burials in the 7-m high and 42-m in diameter tumulus 21 of the necropolis Chegem II north of Nal'chik. Present in tomb 4 were an axe (Fig. 28) and a flat axe, a gouge and a hook, six stone arrowheads and four clay vessels. The stone sceptre is particularly noteworthy¹⁰⁷. Tomb 5 contained a bronze axe, a chisel, a hook and a broken stone axe¹⁰⁸.

In the kurgan of Kishpek, 4.4 m high and 50 m in diameter, north of Chegem, the deceased male lay in a stone cist (Fig. 29, I-III), equipped with an axe (Fig. 29,10) as well as a flat axe, chisel, awl and dagger. Two small gold rings were status indicators. At least two slabs of the stone cist were – as in the case of Nal'chik – reused anthropomorphic stelae. The certainly outstanding object of this tomb equipment is the 43-cm high bronze cauldron¹⁰⁹.

The burial mound of Inozemtsevo, located between Pyatigorsk and Mineralnye Vody, was originally over 7 m high and 50 m in diameter. It contained a central, unfortunately robbed burial of a 55 to 60-year old man¹¹⁰. Among the grave goods (Fig. 30) were two shaft-hole axes (Fig. 30,1-2), a flat axe (Fig. 30,5), two bronze daggers (Fig. 30,3-4) and several arrowheads made of flint. Only a few gold beads and a few strips of gold sheet bear witness to what was probably originally a much more extensive endowment made of precious metal. Three metal vessels (Fig. 30,7-9) belong to the technically most advanced products of that time. In addition, there are seven large clay vessels.

In tomb 18 of kurgan 1 of the tumulus necropolis of Mar'inskaya 3, raion Kirov, krai Stavropol', was a richly furnished grave (Fig. 31) with an early shaft-hole axe, two knives, a dagger, a flat axe and two awls. Further, the most important finds are a stone sceptre and two golden rings, which clearly indicate the high social status of the deceased person¹¹¹. The grave can be dated to around 3350 BCE¹¹².

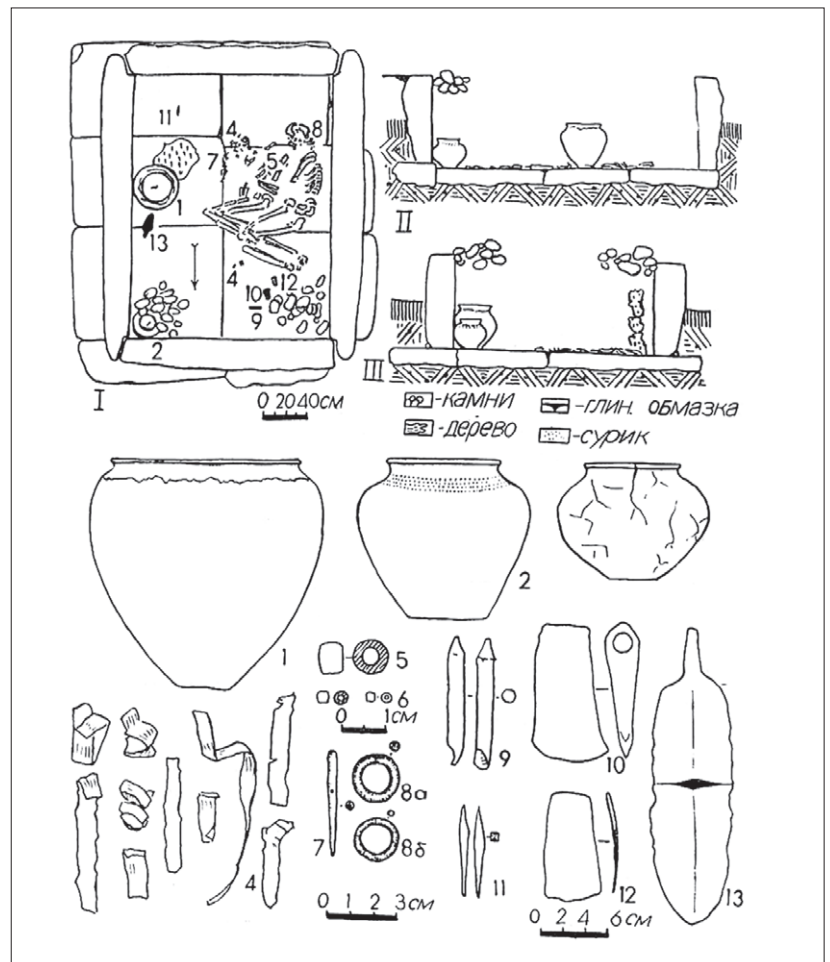

Fig. 29 Kishpek, Kabardino-Balkaria, Russian Federation. Grave goods.

Nikolai I. Veselovskii also uncovered a grave with a shaft-axe (Fig. 32,12) in a 5.35-m high kurgan near Kostromskaya, east of Maikop. The other grave goods included a golden temple ring (found on the chest of the deceased), several flint arrowheads (Fig. 32,7-11), a flat axe (Fig. 32,4) and two daggers (Fig. 32,5-6)¹¹³.

In 1898 Veselovskij found a stone "house"-shaped burial chamber in kurgan I of Novosvobodnaya (formerly Tsarskaia). The grave goods (Fig. 33) consisted of golden and silver pins, rings and beads, a bronze vessel, a hook mounted with figures of two fighting men (Fig. 33,14),

107 Vetrosov/Nagoev 1984, 27, 42, Fig. 10,2.7.10.11; 45, Fig. 11,1; 47, Fig. 13,3-8.

108 Vetrosov/Nagoev 1984, 27, 42, Fig. 10,3.6.9; 47, Figs. 13 and 16.

109 Chechenov 1984, 165-173, Fig. 9.

110 Korenevskii/Petrenko 1982.

111 Kantorovič/Maslov 2008; Kantorovich/Maslov 2009.

112 Kantorovič/Maslov 2008, 13.

113 Munchaev 1975, 257-259, Fig. 57.

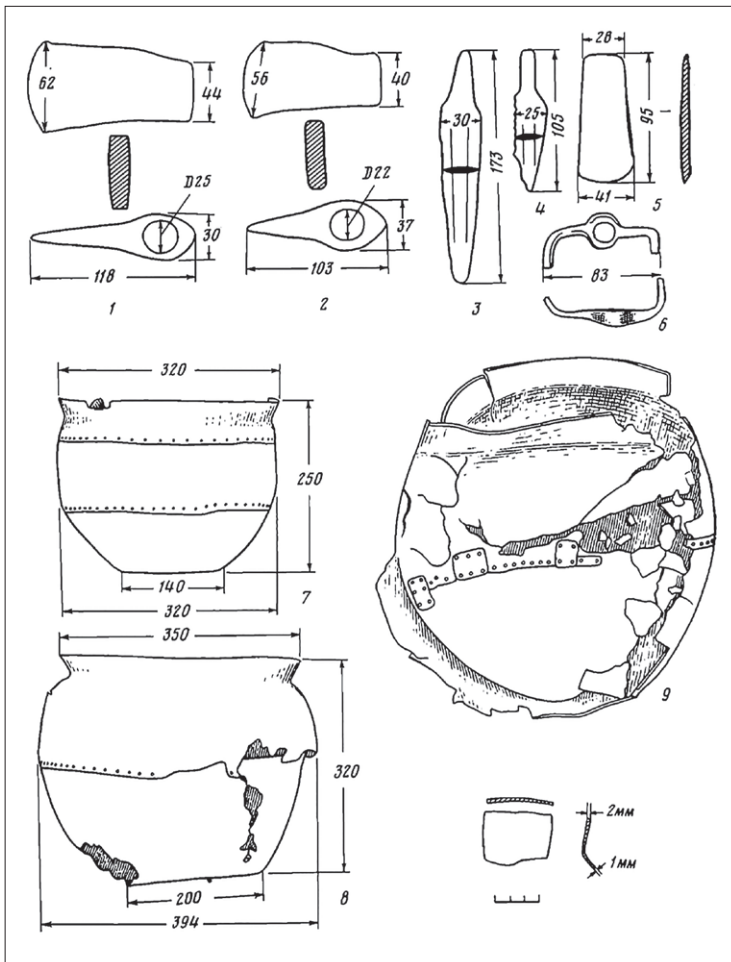

Fig. 30 Inozemchevo, krai Stavropol, Russian Federation. Grave goods.



Fig. 31 Mar'inskaya 3, krai Stavropol, Russian Federation. Grave goods.

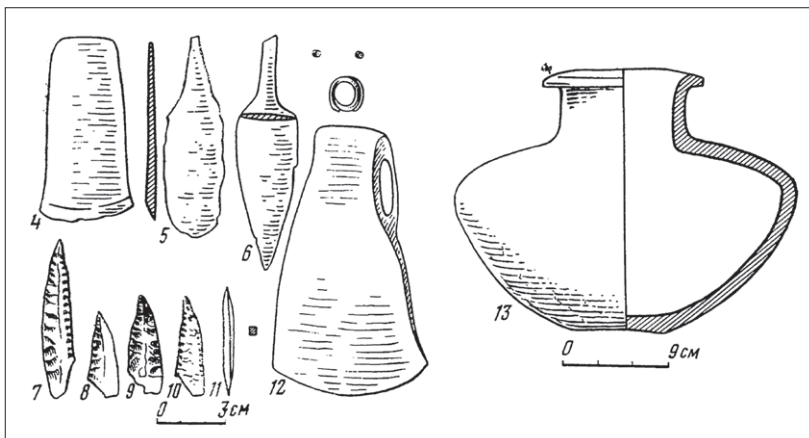

Fig. 32 Kostromskaya, Kabardino-Balkaria, Russian Federation. Grave with shaft-hole axe.

114 Otchet Imperatorskoj Archeologicheskoi Kommissii za 1898 g. (1901) 33–38, Pls. I–VI; Gimbutas 1956, 60–61, Fig. 30.

115 Korenevskii/Rezepkin 2008.

a dagger, two gouges and two axes (Fig. 33, 18–19)¹¹⁴. The 14C date for this burial published by Sergei N. Korenevskii and Alexej Rezepkin falls in the last quarter of the 4th millennium BCE¹¹⁵.

For the second kurgan in Novosvobodnaya, excavated in 1898, two 14C dates from the early 3rd millennium BCE are available. A new 14C date falls in the last quarter of the 4th millennium BCE¹¹⁶. The dates are very different, without any plausible reasons being given¹¹⁷. Since these contradictions cannot be clarified here, it is recommended not to consider this particular grave in the question of dating.

116 GRA 24441: 4270 ± 45 BP and GRA 21334: 4200 ± 60 BP (Korenevskii/Rezepkin 2008, 123 Nr. 60–61); GRA 57655: 4445 ± 35 BP (Trifonov *et al.* 2018).

117 Trifonov *et al.* 2017 refer to impurities.

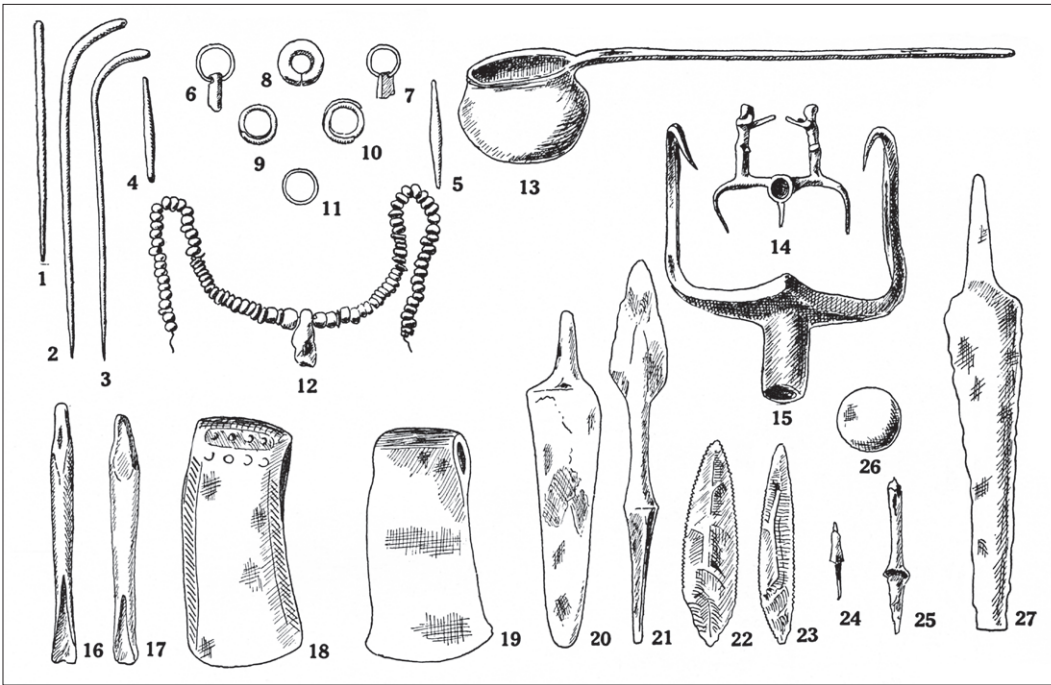

Fig. 33 Novosvobodnaya (formerly Tsarskaya), Adygea, Russian Federation. Kurgan I of 1898: metal grave goods.

The richest grave of the cemetery was grave 5 of kurgan 31, with the burial of an adult and a child. The grave goods found there consisted of four shaft-hole axes (Fig. 34, 3–4, 6–7), two further axes with neck knob (Fig. 34, 5, 8), numerous daggers, two gouges and numerous other metal grave goods. One 14C date (Ki-13822) lies in the 1-sigma area between 3701–3384 calBCE, and the other 14C date (Ki-13822a) is between 3642–3378 calBCE. Noteworthy for this grave is the 65-cm long bent sword¹¹⁸.

The axes from the cemetery of Novosvobodnaya (“Klady”) date to the second half of the 4th millennium BCE, as the numerous 14C data from different graves show¹¹⁹. There, in grave 1 of kurgan 30 a man and a woman were buried. The woman was furnished with golden and silver beads, a golden ring and a silver pin. The man was buried with a dagger (Fig. 35, 8) and a massive shaft-axe (Fig. 35, 11)¹²⁰. The 14C date is in the 1-sigma range between 3500–3348 calBCE, and in the 2-sigma range between 3508–3128 calBCE.

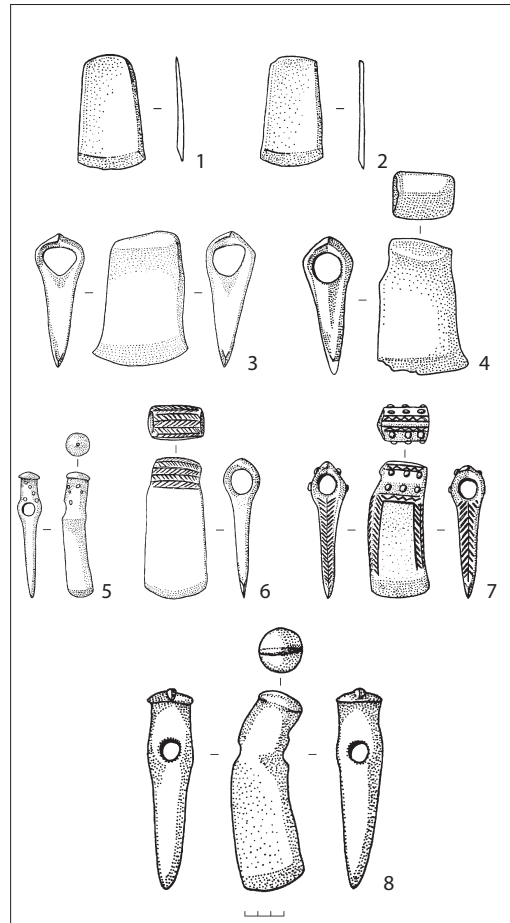

Fig. 34 Novosvobodnaya (“Klady”), Adygea, Russian Federation. Kurgan 31, tomb 5.

118 Rezapkin 2012, 91, Tab. 6.

119 Rezapkin 2012, 91, Tab. 6.

120 Rezapkin 2000, 59–61, Pls. 46–47 (for the 14C date, see p. 22).

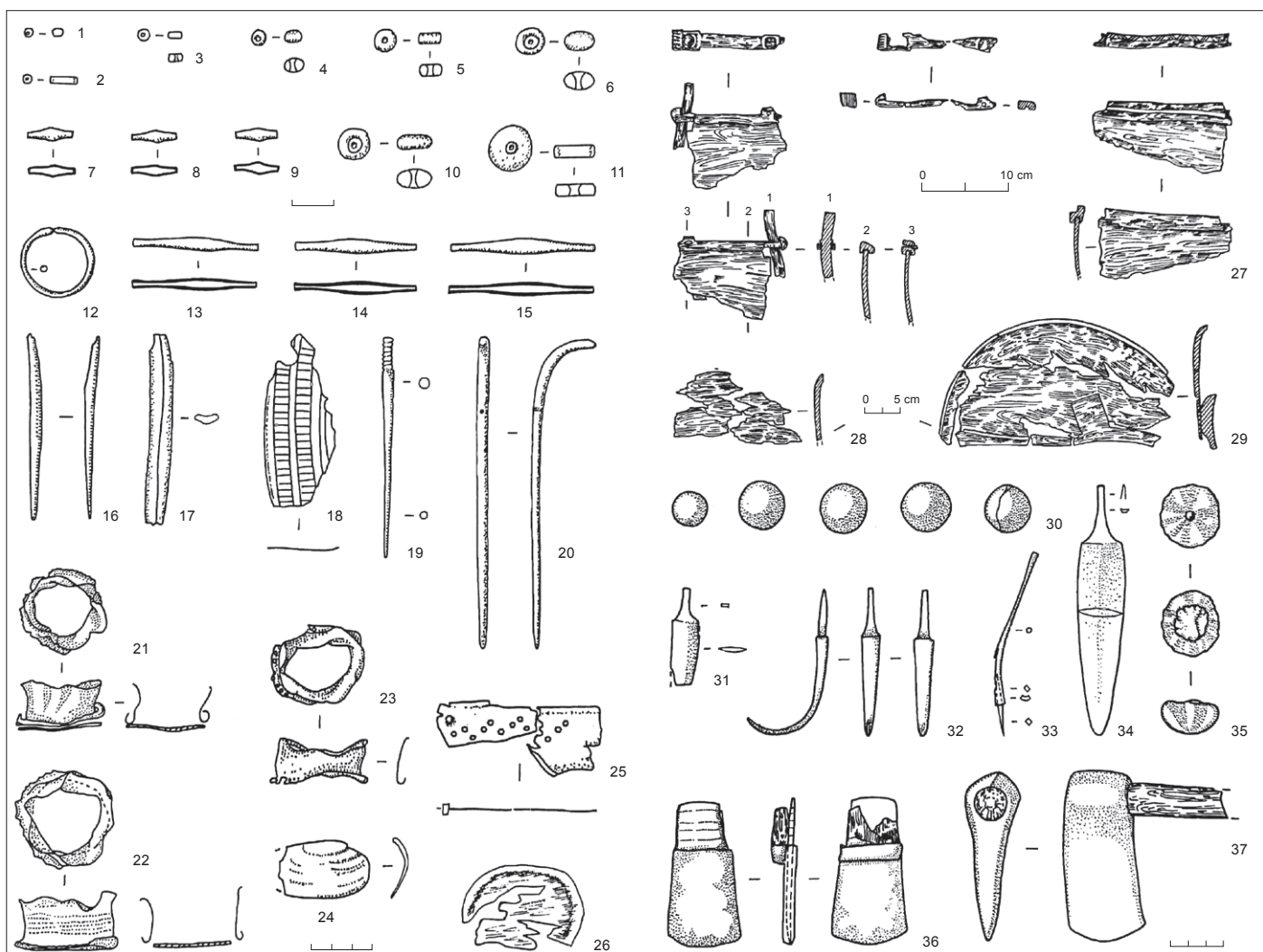

Fig. 35 Novosvobodnaya ("Klady"), Adygea, Russian Federation. Kurgan 30, tomb 1.

No 14C dates are published for grave 4/1 with shaft-hole axe, flat axe, dagger and nose gag, and grave 15/1 with shaft-hole axe and two daggers in Klady. Also, grave 28/1 (Fig. 36) with one shaft-hole axe and five daggers should be highlighted¹²¹.

Recently, the Maikop settlement of Chekon in the Lower Kuban area was investigated within the scope of rescue excavations¹²². Concerned here are almost exclusively finds in pits, including, among others, three daggers and an axe. The calibrated 14C data belong to the 34th–29th centuries BCE¹²³.

Finally, in the Crimea there is another important evidence for an early shaft-hole axe. The central grave 3 in kurgan 1 of Dolinka (Kurban-Bajram) contained, apart from the shaft-hole axe (Fig. 37,2), a gouge (Fig. 37,1), a flat axe (Fig. 37,3) and a fork-shaped object (Fig. 37,4). It is an inventory comparable to that in the Novosvobodnaya cemetery and can be dated to the second half of the 4th millennium BCE. Also, the recently published 14C date proves that the grave dates between 3500 and 3300 BCE¹²⁴.

Another find of Maikop-type objects from a quarry near Krasnoperekopsk in the Crimea

121 Rezapkin 2000, 57–58, Pls. 39–41.

122 Yudin/Kochetkov 2019, 85, Fig. 11,20.

123 Korenevskii/Yudin 2019, 67–68.

124 Ivanova/Rassmann 2014, 214.

Axes from hoards 3500–2900 BCE

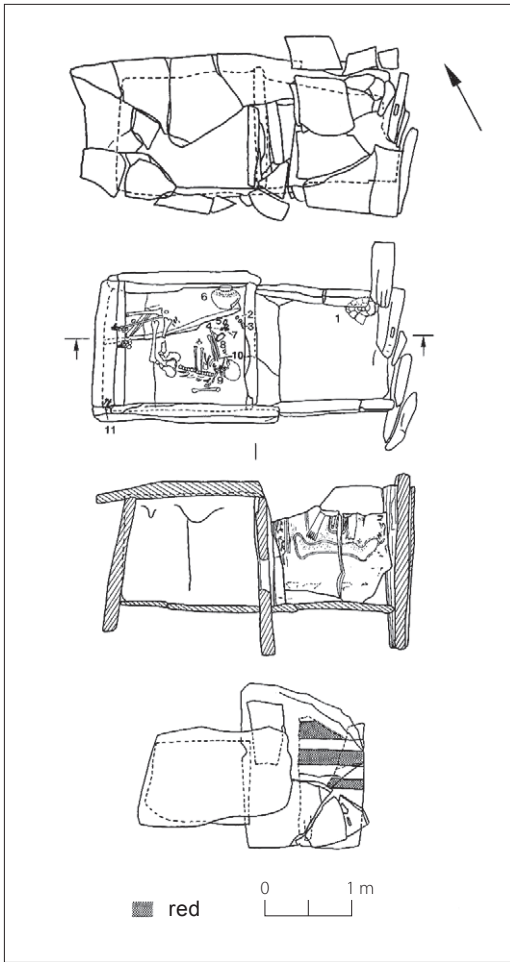

Fig. 36 Novosvobodnaja (“Klady”), Adygea, Russian Federation. Kurgan 28, tomb 1.

consists of an axe measuring only 8 cm, a flat axe, a chisel and a dagger¹²⁵.

South of the Caucasus, the typologically early shaft-hole axes have so far only been registered as single finds¹²⁶. Presumably, they represent to no small extent single deposits. These valuable weapons were certainly not accidentally lost finds, as they were thought to have been in the 19th century AD. Of course, unrecognized destroyed graves or hoards cannot be completely ruled out.

The typological similarities between the axes from the grave of Maikop and other Early Bronze Age graves in the North Caucasus and the early shaft-hole axes in the Carpathian Basin were noted early on. Yet Vulpe wanted “to explain by chance or leave unexplained for the time being the surprising formal similarities between the axe type Baniabic (today Vâlcele, S.H.) and axes from the North Caucasus and Central Russia [...]. No such specimens are known from the intermediate zone”¹²⁷.

Unfortunately, this conclusion was already more than improbable when it was written down, over 50 years ago. Instead, the similarity in form should be far more the starting point for a number of revisions of the dating. With the early dating of the grave of Maikop to before the middle of the 4th millennium BCE, the Carpathian shaft-hole axes with “plump” outlines, i.e. the Baniabic and Fajsz types, also move into the second half of the 4th millennium BCE¹²⁸. Radu Băjenaru, Alin Frînculeasa, Vajk Szeverényi, Janos Dani and Bianca Preda have also drawn this chronological conclusion in their studies¹²⁹.

Elke Kaiser, on the other hand, has recently argued for a longer life span of axes with a simple form in the “eastern” distribution area. She cites the 14C dated graves of Velikent and Il’inskiï for this¹³⁰. However, since these do not belong to the Maikop-Vâlcele type, but instead to younger types (see below), this proposal is futile. She further argues that until now no shaft-hole axe of the types Baniabic and Fajsz are known from South-eastern Europe, which can be dated reliably to the time before 3000 BCE, neither scientifically nor with a closed find context. This is not to be expected from axes that were deposited as single or hoard finds, which is why a solid typo-chronological order of the find material remains a task for archaeology.

Volker Heyd and Katherine Walker also think that the shaft-hole axes did not begin in

125 Klochko/Kozymenko 2017, 45, Fig. 1.

126 Gambashidze *et al.* 2010 *passim*.

127 Vulpe 1970, 26.

128 Hansen 2011.

129 Dani 2013; Szeverényi 2013; Băjenaru/Frînculeasa 2014; Preda 2015.

130 Kaiser 2019, 236.

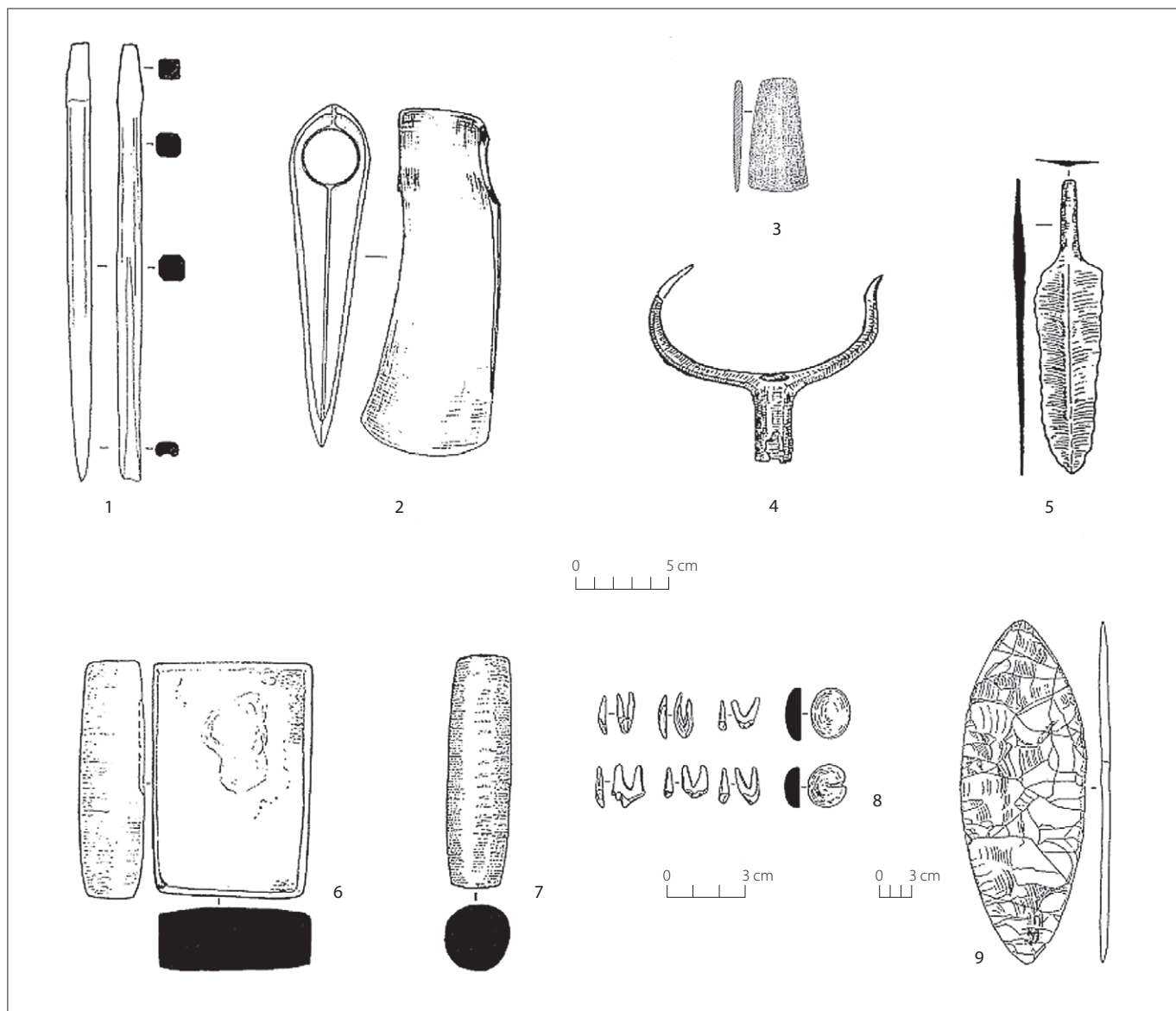

Fig. 37 Dolinka (Kurban-Bajram), Crimea. Kurgan 1, tomb 3.

the Carpathian Basin until around 3000 BCE¹³¹. In their overview table, the gap is clearly visible, which allegedly existed between the last axe-adzes of the Nógrádmargal type around 3700 BCE and the first shaft-hole axes around 3000 BCE. Nonetheless, a 700-year long gap in the use of axes probably did not exist, nor did the geographical gap exist between the Carpathians and the Caucasus, which perplexed Vulpe at the time.

131 Heyd/Walker 2014, 676, Fig. 35,1.

132 Bátorá 2003.

In 2003 Jozsef Bátorá discussed a series of early shaft-hole axes found in graves between the Caucasus and the Carpathians¹³². In the meantime, comparable early axes from the “intermediate zone” between the Caucasus and the Carpathians have been found in depositions. Here to mention is a wedge-shaped shaft-hole axe found together with several short swords in Ivan’ky, Mankivka raion, oblast Cherkassy (Fig. 38)¹³³. Another very archaic looking axe

133 Klochko/Klochko 2013, 50, Fig. 8.

was also found together with a dagger blade in Chapayivka, oblast Cherkassy¹³⁴. Other axes are known as single finds along the Dnieper River¹³⁵. The hoard of Ivonovka, oblast Vinnitsya in Podolia, includes a Vâlcele type shaft-hole axe, two flat axes and a chisel¹³⁶.

In the Carpathian Basin, the find of Vâlcele (Baniabic/Bányabükk) near Cluj (Fig. 39) is the most significant deposition, which probably contained more than 40, and according to Szeverényi at least 55 such axes¹³⁷. Vâlcele thus represents the most extensive deposition of the 4th millennium BCE in Europe. The axes preserved in Debrecen and Cluj weigh between 800 g and 1420 g. 8 axes weigh less than 1000 g, and 16 axes weigh more than 1000 g. Hence, probably much more than 50 kg of copper were deposited in Vâlcele.

If one compares the number of axes, and of course also their weight, with Caucasian grave finds, the special nature of the deposition becomes even clearer. In the Caucasus the addition of an axe was linked with the social elite. The number of excavated graves with an axe as grave good in the Caucasus is less than 20.

The hoard of Vâlcele was probably deposited nearby a small brook. According to Tudor Soroceanu the “find site is 47 steps behind a small water mill at the foot of a hill. The mill is on the left side of the road from Cluj to Turda, about 2 km southeast of the village of Bányabükk, opposite kilometre 167 of the so-called state road in the valley of the brook Tur, in the district of the village Pusztaszentmárton (Mártinești)”¹³⁸. This description seems plausible in view of the Josephinian map (Fig. 40a–b), which was made between 1769 and 1773. However, there are also later indications that deviate from this place name. Considering the important rank of this deposit, new research on the site is highly desirable.

The hoard from Fajsz, most of which is lost today, contained three axes (Fig. 41, 1–3) and two chisels (Fig. 41, 4–5)¹³⁹. Unfortunately, noth-

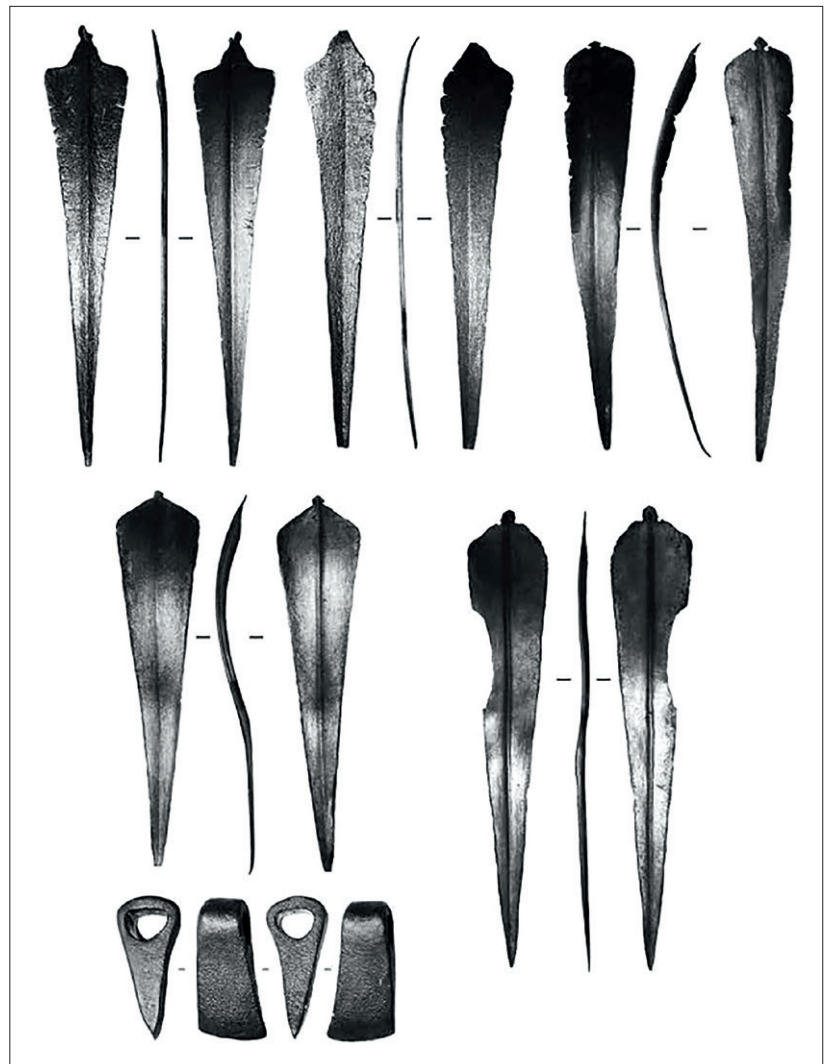

ing more is known about the circumstances of its discovery. In the Carpathian Basin the early shaft-hole axes were often deposited as single objects¹⁴⁰. Unfortunately, the circumstances under which they were found usually cannot be described in more detail. One exception is the axe from Hărău, jud. Hunedoara, which was recently published extensively by Catalin Nicolae Rîșcuța¹⁴¹. The axe consisting of almost pure cop-

Fig. 38 Ivan'ky, obl. Cherkassy, Ukraine. Hoard with short swords and axe.

134 Klochko/Klochko 2013, 52, Fig. 10.

135 Nechitailo 1991, 30, Fig. 4, 1–4; Staiki, oblast Kiev; Verchnodniprovsk, oblast Dnipropetrovsk; Balki, oblast Zaporizhzhya.

136 Klochko/Kozyomenko 2017, 52, Fig. 16.

137 Soroceanu 2012, 109–114, Pls. 37–42; Szeverényi 2013, 663.

138 Soroceanu 2012, 109.

139 Hampel 1903, 427.

140 Map in Dani 2013; the axe type Fajsz found in Sasa (Bejinariu/Kadar 2003; Kadar 2007, Pl. 28, 114).

141 Rîșcuța 2016.

Fig. 39 Vâlcele (Baniabic/
Bányabükk) near Cluj, Romania.
Hoard with 55 axes.

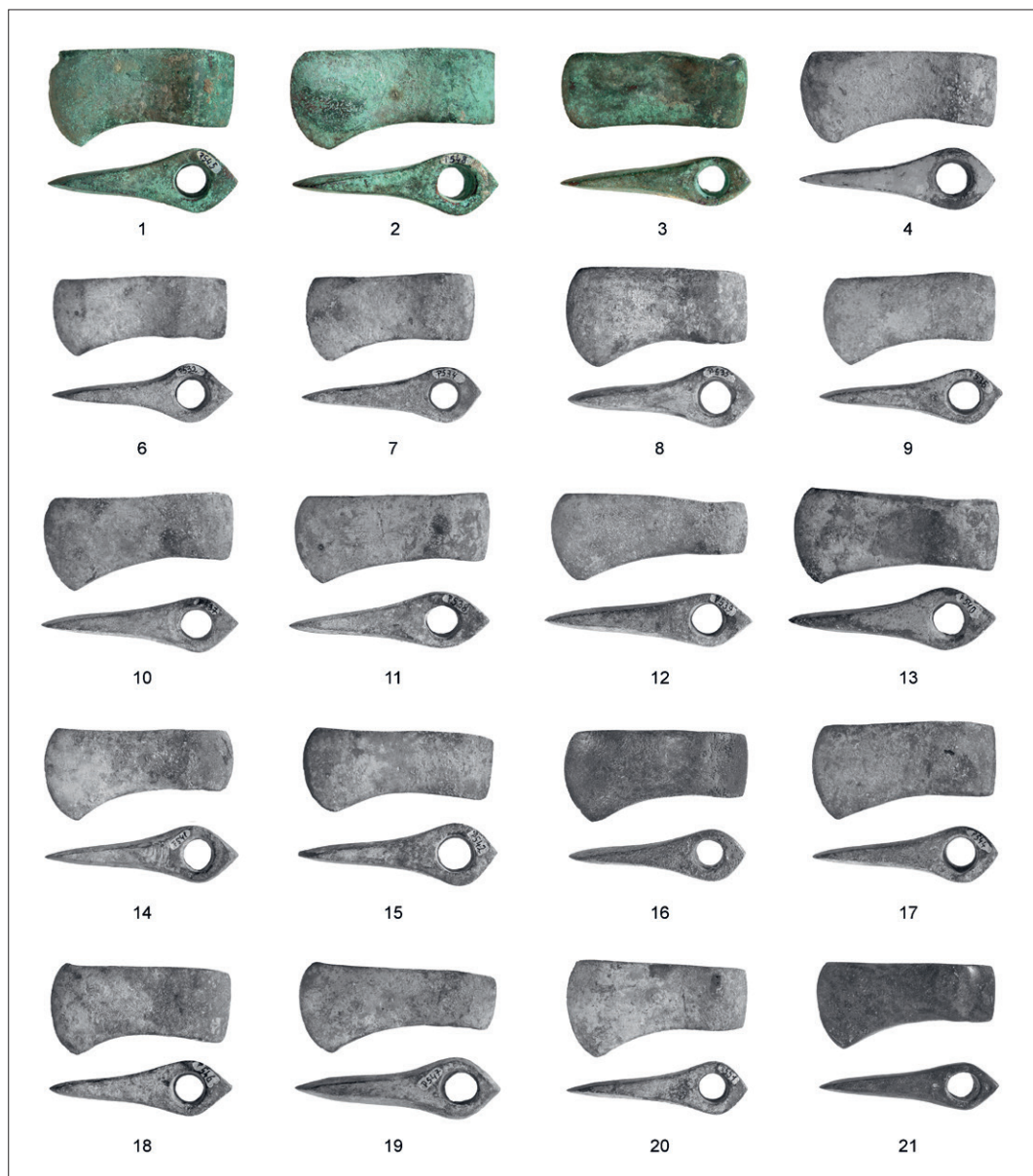
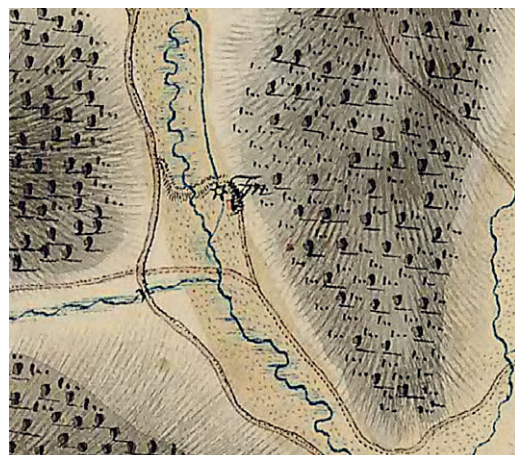

Fig. 40a–b Vâlcele (Baniabic/
Bányabükk), Romania. Location
of the hoard in the Josephinian
map.



per was found on a spur outside a defined settlement area and is interpreted as an intentional deposition (Fig. 42). The axe of type Fajsz is damaged at the shaft hole; it is well comparable with the axe from Brno-Líšeň (Fig. 43,3).

Bátora already showed that the Kozarac axes belong to the early 3rd millennium BCE and thus left open the possibility for an older dating of the axes of the Baniabic and Fajsz type. The finds from the hoards in the Carpathian Basin are not dated by 14C data and, thus, can only be typologically connected to the Caucasian axes. The hoard from Brno-Líšeň (Fig. 43) was found in the Staré Zámky hilltop settlement in the youngest settlement layer I, whose pottery partly still corresponds to the Jevišovice C1-phase, but mainly to Jevišovice B¹⁴². According to Martin Furholt, the Jevišovice B group can be expected in Moravia as of 3100 BCE¹⁴³. Therefore, the hoard is not dated more precisely, but the available data does not contradict an assignment of the axe to the late 4th millennium BCE¹⁴⁴. Remarkably, the hoard of Brno-Líšeň is also significant as holding a combination of types: not only the shaft-hole axe, but also the flat axe and the chisel with pyramid-shaped shaft are also common in the Caucasus (Fig. 44)¹⁴⁵.

However, the axe differs from the Caucasian examples in that it was made of pure copper¹⁴⁶. The 815-g axe from the Slovakian Dolný Pial, okr. Levice, is very similar (Fig. 45)¹⁴⁷. According to the spectral analysis, it consists of pure copper with a content of less than 1%. For the axe from Brachwitz, Saalkreis, 1% and for the axe from Zscheiplitz, Burgenlandkreis (Fig. 46), 0% arsenic is recorded¹⁴⁸. The axes from Vâlcele are also made of pure copper¹⁴⁹.

Recently, Bianca Preda aptly summarized the state of research and posed the question of how to explain the change in deposition: from the axe in the grave (in the Caucasus) to the axe in the hoard (in the Carpathian Basin)¹⁵⁰. Ultimately,

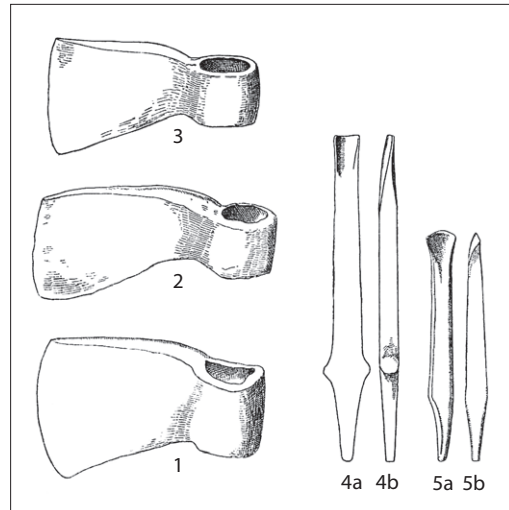

Fig. 41 Fajsz, Kr. Kalocsa, Kom. Bács-Kiskun, Hungary. Hoard.



Fig. 42 Hărău, jud. Hunedoara, Romania. Single deposition of an axe.

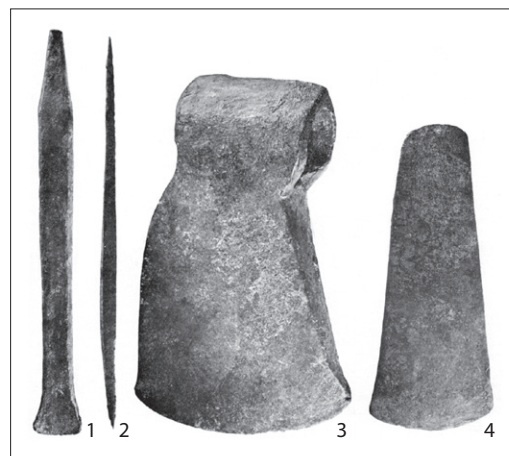

Fig. 43 Brno-Líšeň, hilltop settlement Staré Zámky, Czech Republic. Hoard.

142 Benešová 1956.

143 Furholt 2013.

144 The 14C date for Brno-Starý Lískovec listed in Table 10 in Kaiser 2019, 237 (and also already in Ivanova 2016, 407) is irrelevant for dating the axe from Brno-Staré Zámky, because it is from a different settlement.

145 Munchaev 1994, 206, Fig. 54.

146 SAM 3350.

147 Vladár 1970.

148 Mildenerger 1950; Kaufmann 2002; SAM 41532 Zscheiplitz.

149 SAM 8952–8971.

150 Preda 2015.

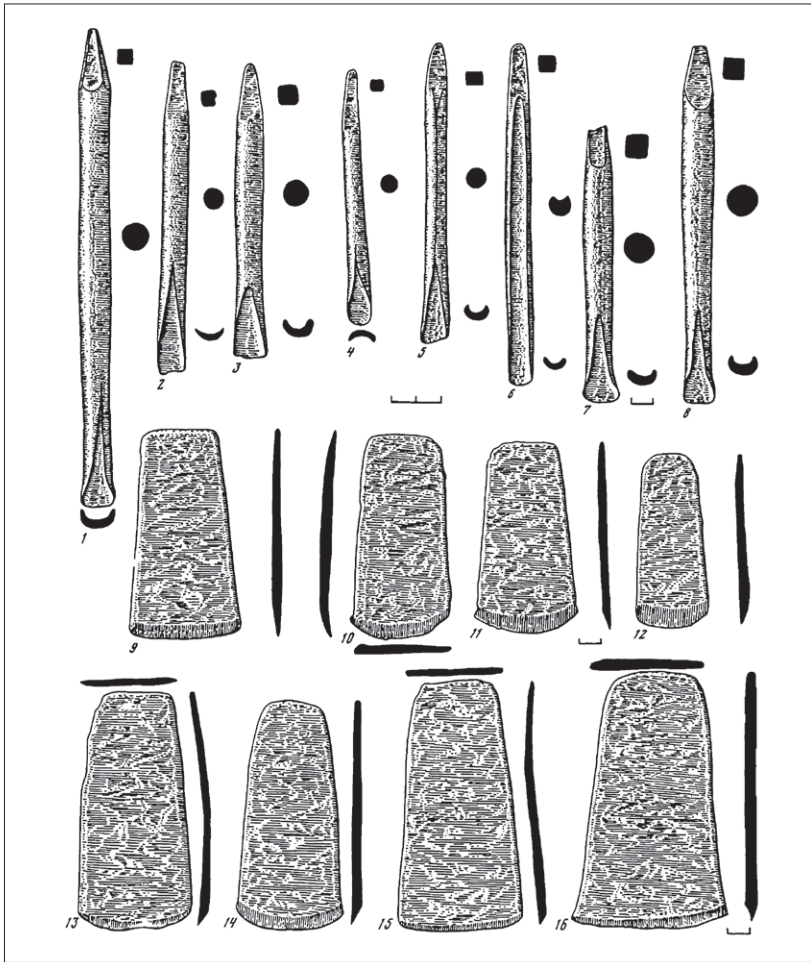

Fig. 44 Flat axes and gouges from various sites in the North Caucasus.



Fig. 45 Dolný Pial, okr. Levice, Slovakia. Axe.

151 Băjenaru 2010, 154.

152 For the Urnfield Culture in Central Europe, see Hansen 1994; for the Early Iron Age in Greece, see Morris 1987.

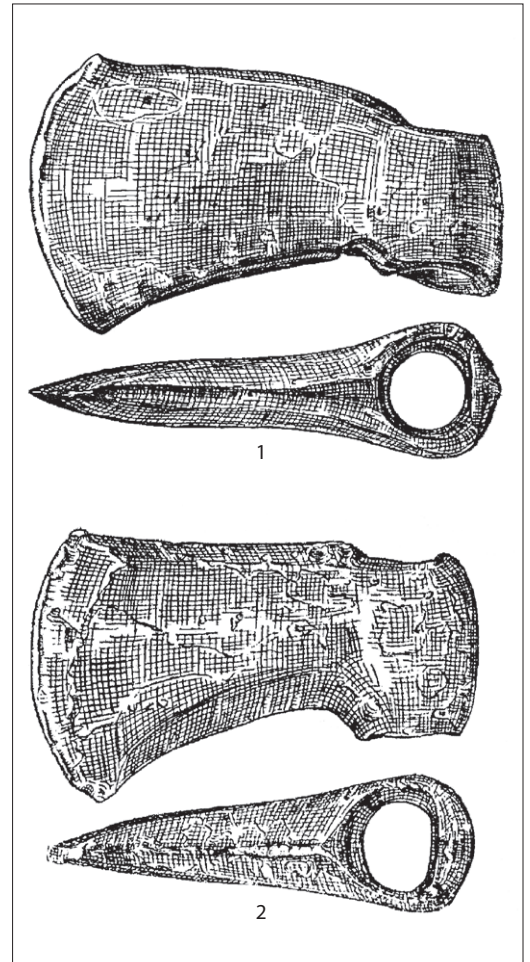

Fig. 46 Axes: 1 Brachwitz, Saalkreis; 2 Zscheiplitz, Burgenlandkreis, Federal Republic of Germany.

of course, this question cannot be answered, but we can make assumptions. Radu Băjenaru suspects that the link to deposition expresses the social significance of the axe.¹⁵¹ However, this is due to a double movement of thought, namely the significance attributed to the hoard, on the one hand, and, on the other, the significance attributed to the axe. In the Eastern Carpathian Basin, the deposition is the “social arena” and there the object at the top of the social scale, but also the economic scale of values finds its place. In a certain sense, the grave or the hoard seem to fulfil similar functions, yet they are rarely found simultaneously in one and the same region¹⁵². In some cases the similarities are undisputable. A hoard like Brno-Líšeň could also have been used as a functional set of grave goods in the Cauca-



Fig. 47 Vozdvizhenskaja, krai Krasnodar, Russian Federation. Grave.

sus. The objects lay crossed, one on top of the other, a common way of placing Early Metal Age weapon sets in graves. The grave of Vozdvizhenskaja, krai Krasnodar (Fig. 47) is also mentioned here as an example of such a set of functional weapons and equipment set¹⁵³.

Intermediate consideration of the origin of the shaft-hole axe

In summary, it can be said that the clumsy shaft-hole axes of the Maikop-Välcele type predominantly belong to the second half of the 4th millennium BCE, which is sufficiently proven by 14C data from graves in the Caucasus and Crimea. An earlier production may be postulated on the basis of the grave in the great kurgan of Maikop. According to 14C data, the use of these axes in the 30th century BCE is also possible (Fig. 48). In the 3rd millennium BCE axe forms with a stepped shaft hole were used. There is no reason to assume that the Maikop-Välcele axes did not reach the Carpathian Basin until

the early 3rd millennium BCE¹⁵⁴. In contrast to Caucasian axes made of arsenic bronze, the Carpathian axes are made of pure copper and thus prove their local production, which ultimately continues the tradition of the axe-adzes¹⁵⁵.

The Caucasus probably played the decisive role in the development of these weapons. The step from the axe with short spiked neck (Fig. 23) to the shaft-hole axe of the Maikop type (Fig. 24) was not great. Also, the range of variation of axes, e.g. in Klady's grave 31/5, suggests that the Caucasus had become a field of experimentation for axes. Besides the heavy axes of the Maikop-Välcele type, other axe shapes were in use, too. Tomb 35 in the Oleksandrivka burial mound west of Odessa contained a small ensemble of weapons with a dagger, a flat axe and an axe with a diamond-shaped outline (Fig. 49)¹⁵⁶. The tomb is assigned to the Usatovo Culture with view of the ceramics. A very similar specimen was found in a hoard in Kałdus, okr. Chełmno (Fig. 50) in Kujawy¹⁵⁷. A coincidental similarity of the axes can be ruled out, because the axe had been deposited in Kałdus together with a dagger of the

153 Popova 1963.

154 Cf. for instance Ivanova 2016, 407.

155 Metal analysis of the Caucasian axes in: Ryndina/Ravich 2019, 125, Tab. 17; 158, Tab. 26; 161, Tab. 27.

156 e-Jahresbericht 2019 des DAI – Eurasien-Abteilung, 247, Fig. 4 (B. Govedarica).

157 Adamczak *et al.* 2015.

Fig. 48 Graves with axes:
14C data.

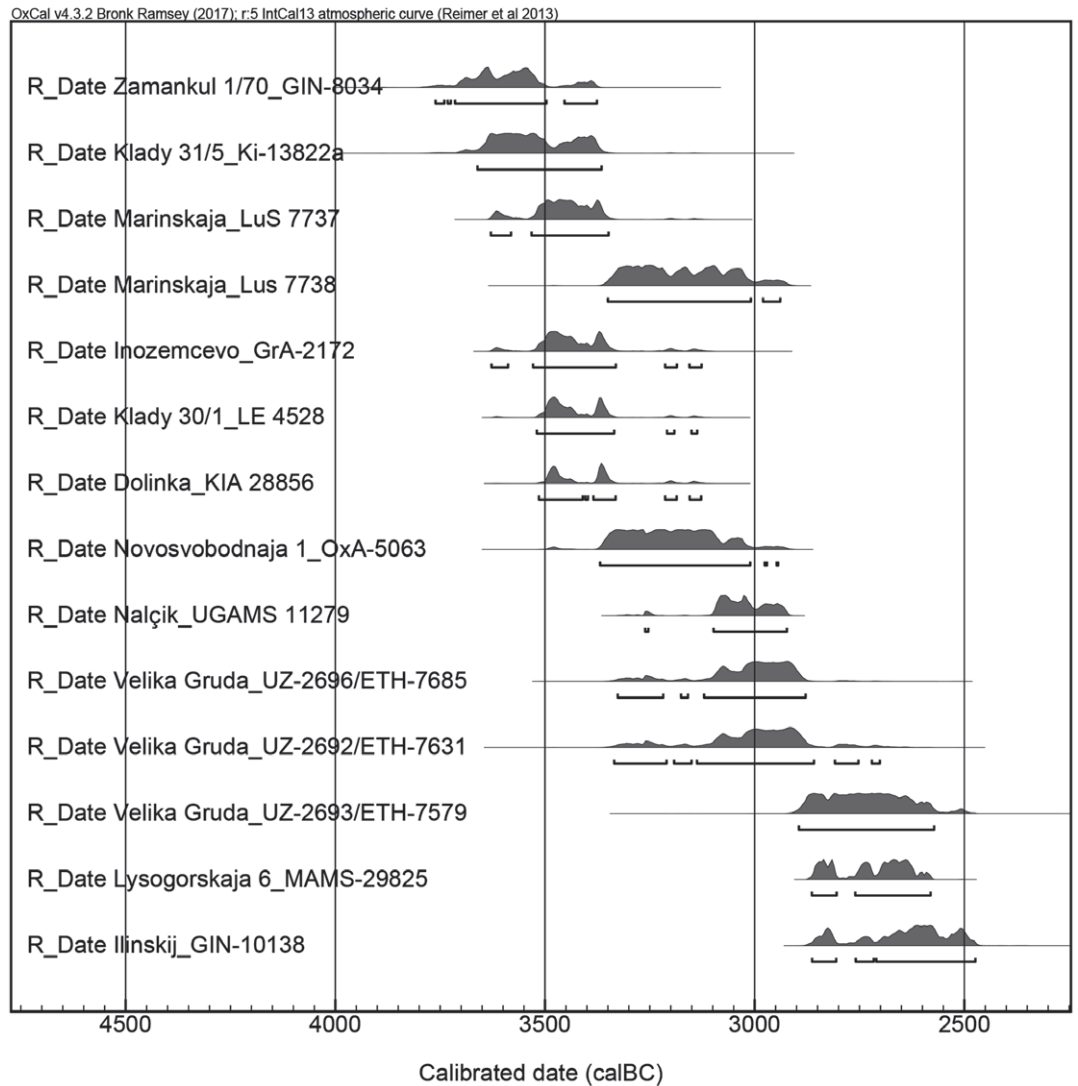

Usatovo type. This splendid 20.7-cm long specimen finds convincing comparisons only in the eponymous cemetery¹⁵⁸. The dagger of Aspenstedt is much smaller¹⁵⁹. This hoard was found in a settlement of the Funnel Beaker Culture. The authors date the pottery of this settlement phase to the time 3600/3500–3200/3100 calBCE. This dating fits very well with the time frame of the Usatovo Culture as defined by Blagoje Govedarica and Igor Manzura, as well as with the assessment that the Usatovo Culture must be regarded as a mediator of the new arsenic copper metallurgy and other innovative elements in Europe

at that time¹⁶⁰. It is equally consistent with this that the axe contains 1.4% and the dagger even 5.2% arsenic.

The technical prerequisites for the production of shaft-hole axes had basically been established for a long time. Nevertheless, the relocation of the shaft-hole to the heel of the axe was obviously a great step forward, if one measures it by its success. The axe became easier to handle and had greater penetrating power. However, this also increased the risk that the casting would fail or that the axe would break at exactly this thinnest point. I suspect that the arsenic alloy

158 Ravich/Ryndina 1995.

159 Müller 2013.

160 Govedarica/Manzura 2011, 54.

created the conditions for the success of the casting here. The thinnest point in particular must not be weakened by casting blowholes.

If one wishes to understand why the shaft-hole axe became such a successful innovation that replaced all the other previously common variants of axe-adzes, one must consider not only at the technical processes, but also at the context in which this took place.

First of all, the dagger should be highlighted as another early innovation. As already mentioned, especially for the blade technology, the alloy was a condition for the success of the casting. The dagger in the Maikop tomb (Fig. 24) represents an early masterpiece of the casting technique: it is 34.7 cm long¹⁶¹. Thus it already comes into the ambiguous category of ‘short swords’. Two silver rivets were used to fasten the blade to the organic hilt. At about the same time daggers of the Usatovo type (Fig. 50) also reach a length of just over 20 cm. The development of blade technology was a no less far reaching innovation, which only a few centuries later in the Caucasus took another technical step with the 63.5-cm long sword from tomb 31/5 of Novosvobodnaya¹⁶². It was made at about the same time that the swords of Arslantepe near Malatya in Eastern Turkey were in use¹⁶³. The longest of them also measured 62 cm. The short swords of Ivan’ki can probably be dated to the same time (Fig. 38). The production of long blades was a technical challenge, which was not mastered in many parts of Europe for a long time and was only realized in the second millennium BCE.

The third weapon-technological innovation is the spearhead with pyramid-shaped shaft. Spearheads were found in kurgan 1 of 1898 (Fig. 33) and in tomb 47 in kurgan 11 of Novosvobodnaya¹⁶⁴. Such spearheads have been found in larger numbers in the South Caucasus. They are also present in the weapons’ complex in room 113 of the collapsed building III in layer VIa in Arslantepe. Furthermore, they are represented in larger numbers from the “Royal Tomb” in Arslantepe, which was built around 3000 BCE¹⁶⁵.



Fig. 49 Oleksandrivka, obl. Odessa, Ukraine. Grave containing a small weapon ensemble: a dagger, an axe with a diamond-shaped outline (1), a dagger (2) and a flat axe (3).



Fig. 50 Kaldus, okr. Chelmino, Poland. Hoard.

The shaft-hole axe, the dagger and the bow and arrow represented a kind of standard equipment, which was reserved in the grave for the leading social group. This functional set – but completely in stone – was also part of the grave equipment in the rich grave 5 in kurgan 31 in Novosvobodnaya: a white stone hammer axe

161 Catalogue St. Petersburg 2013, 312, Fig. 20,10.

162 Catalogue St. Petersburg 2013, 328, Fig. 24,5.7.

163 Frangipane/Palmieri 1988, 394, Figs. 58–61.

164 Rezepkin 2012, 22, 322, Pl. 4.

165 Palumbi 2012.

(a copy of the bronze hammer axe in this grave), a white flint dagger and five arrowheads made of flint¹⁶⁶.

The axe, dagger and bow were a functional unit that was not limited to the Caucasus, but much more widely distributed. In the Alps, Ötzi travelled with exactly this functional equipment – although of a technically more backward version: a flint dagger, a copper flanged axe and a bow. This equipment is found only quite exceptionally in graves of this period. In hoards at most a dagger and an axe are present in combination with each other.

However, the weaponry was eminent not only in terms of technical innovation and military functionality, but also in terms of social and symbolic significance. A new social class displayed its quick-wittedness even in the grave, carrying the most advanced means of coercion as proof that it was always ready to defend its power and wealth with these weapons. This new class was probably the driving force behind the technological developments in which it had the greatest interest. That this was not limited to the Caucasus, but that comparable processes of power concentration took place in Western Europe as well as in Northern Mesopotamia, has been demonstrated several times in recent years¹⁶⁷.

An open question remains as to what weapons were in use in the early urban centres of northern Mesopotamia during the 4th millennium BCE. Evidence of violent conflicts are found, for example, in the period between 3800 and 3600 BCE in Tell Brak¹⁶⁸. There is also evidence of violence for Hamoukar, and it can be indirectly proven by the construction of the city wall in Uruk at the end of the 4th millennium BCE¹⁶⁹. It is clear that slingshots played an important role. At best we can assume that the lances and swords known from Arslantepe were much more widespread in the region.

Depositions in the 3rd millennium BCE

The axes of the 4th millennium BCE were part of richly furnished graves and large kurgans in the North Caucasus. Giulio Palumbi interpreted the direct relationship between the size of the kurgans, the complexity of the grave structures and the concentration of spectacular metal offerings as a funerary ideology, which was meant to emphasize the formation of internally hierarchised communities founded on vertical social relations¹⁷⁰. He understands the embedding of these hills in the landscape as a strategy of naturalizing social organization. The burial mound becomes part of the landscape, and the structure of social inequality connected with it, more precisely, materialized in it, thus becomes part of nature. This observation is very important, because it goes one step farther than the idea that the rows of kurgans along paths or the larger cemeteries legitimized the age-old claims of single kinship groups. These claims are supposedly – let us follow Palumbi – as old as the world's creation, as the (naturalized) hills “prove”.

The offering of numerous metal objects in graves ended with the Maikop-Novosvobodnaya phenomenon at the turn of the 3rd millennium BCE, but the use and enlargement of existing kurgans and the construction of new ones continued without interruption. Only a few graves of the North Caucasian and Yamnaya cultures continued to be furnished with metal objects. As a result, the archaeological visibility of bronze axes is severely impaired, as there is no tradition of hoarding in the North Caucasus.

South of the Caucasus, on the other hand, graves were first equipped with metal weapons and jewellery around and shortly after 3000 BCE. The “Royal Tomb” of Arslantepe was built during or at the end of phase VIB1 and has been dated between the years 3200 and 2900 BCE. It contained 65 metal objects, including nine lanceheads, a

166 Rezapkin 2012, 323, Pl. 5. Catalogue St. Petersburg 2013, 329, Fig. 24,5.11–13.

167 Stein 2012; Hansen 2013a; Jeunesse 2014a; Jeunesse 2014b.

168 McMahon/Sołtysiak/Weber 2011.

169 Schrakamp 2015, 213–214.

170 Palumbi 2012, 55, Figs. 4–7; for the subsequent settlement, cf. now Palumbi *et al.* 2017.

sword, a dagger, four flat axes and three gouges, as well as numerous rings and pins. The heavy axe and bow and arrow are absent among the weapons. Whereas the lanceheads already have practically identical forerunners in the hoard from layer VIA, the flat axes and gouges follow Caucasian forms. At present, the available metal analyses will have to be questioned with regard to the possible origin of the objects in the light of the comparison with the North Caucasus¹⁷¹. Whether population movements from North to South around 3000 BCE were actually responsible for this change in tomb furnishings, as Philip Kohl suspected, will perhaps be answered in the light of bioarchaeological investigations¹⁷².

Palumbi interprets the construction of the tomb on the only sparsely populated settlement hill, which rises 30 m above the plain, as a re-interpretation of the symbolic principles in the North Caucasus. Indeed, there are very few such high burial mounds in the North Caucasus. For example, the (settlement) hill of Malatya could have been a particularly attractive object for the implementation of this symbolic concept.

In Upper Mesopotamia a number of burials are found from this time, which now also furnished with numerous grave goods. At about the same time, grave 12 on Hasek Höyük was also placed¹⁷³. It belongs to the latest phase of the Early Bronze Age. The stone cist grave was buried in the collapse of a Late Chalcolithic house. The approximately 35-year-old man was also richly endowed with metal grave goods (Fig. 51): two lance points (1–2), a dagger (7), two flat axes (5–6), a chisel (8) and a macehead (3) as well as a pin (4). About 700 m west of the settlement hill was the cemetery, where 94 pithos graves were excavated¹⁷⁴. There, too, the burial place might correspond with the social position of the deceased¹⁷⁵. A very similar equipment was found in the Early Bronze Age graves of Karkemish¹⁷⁶. The aforementioned Early Bronze Age cemetery of Bashur Höyük with its abundance of grave goods belongs to this context.

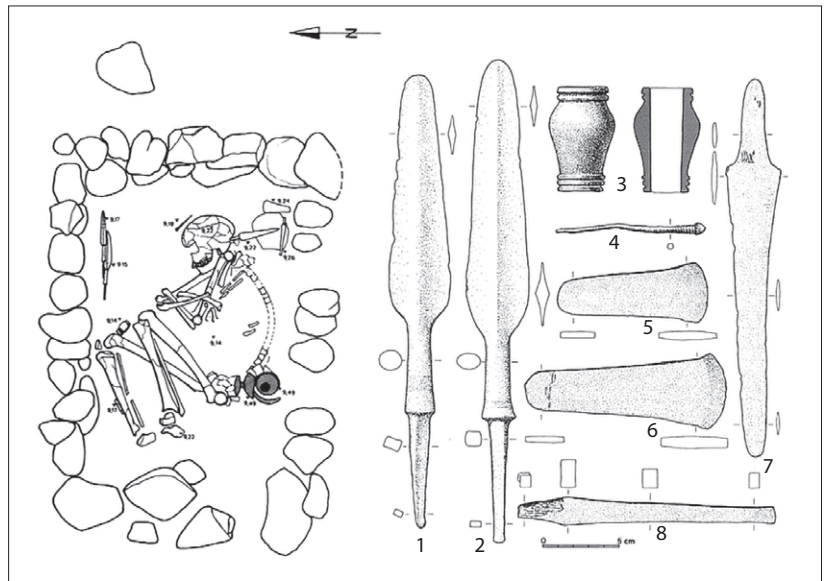

Fig. 51 Hasek Höyük, Turkey. Grave 12.

Fig. 52 Mala Gruda, Kotor, Montenegro. Silver axe.

Exactly in this period there are also some graves with above-average weaponry in Southeast Europe. In the Tumulus Mala Gruda in the Bay of Kotor in Montenegro a golden dagger and a silver axe (Fig. 52) were found in the main burial¹⁷⁷. The dating of this tomb has been moved to the beginning of the 3rd millennium BCE due to finds in two other tombs. In another Montenegrin burial mound – Gruda Boljevića in Podgorica –, identical pottery was found as well as an axe made of finely polished granite with a staff sheathed in gold foil, a form very similar to

171 Hauptmann *et al.* 2002.

172 Kohl 2007, 19–20.

173 Behm-Blancke 1984, 49–53 A. 7–8.

174 Behm-Blancke 1984, 56–58.

175 Lichter 2018, 84.

176 Woolley 1952, Pls. 60–61.

177 Parović-Pešika/Trbuhović 1971.

Fig. 53 Griča, Bosnia and Herzegovina. Hoard





the axe in Mala Gruda¹⁷⁸. The 14C dating for this grave places it at the turn of the 4th and 3rd millennium BCE. This tends to coincide with the dates from the tumulus of Velika Gruda¹⁷⁹.

The slender axe with the long shaft socket from Mala Gruda finds a very good analogy in the hoard of Griča (Fig. 53), where fan-shaped flat axes as well as other shaft-hole axes had been deposited¹⁸⁰. These copper axes have a more slender outline than the Fajz axes and a shaft socket that is set off from the blade body. They are called shaft-hole axes of the type Kozarac, after another hoard¹⁸¹. These axes were also deposited



Fig. 54 Rodotopi, Ioannina, Greece. Hoard.

Fig. 55 Călugăreni, jud. Prahova, Romania. Axe.

in larger series in hoards, for example in Brekinjska, Croatia, 45–50 axes were deposited¹⁸². The southernmost of these large hoards with axes and hatchets was found in Petralona on the Chalkidiki. There four shaft-hole axes, 38 flat axes as well as one chisel had been deposited in a pithos¹⁸³. The axes, however, represent the axe-form Izvoarele. Joseph Maran dates them parallel to the axes of the Kozarac type between the 29th and 25th century BCE. Another type of hoard, the “pure” hoard type comprising exclusively shaft-hole axes, is represented by the find in Rodotopi northwest of Ioannina in Epirus (Fig. 54)¹⁸⁴. It consists of four heavy shaft-hole axes (942 g). Christos Kleitsas assigns them to the type Veselinovo, after Vulpe.

In the Carpathian region, axes of the Veselinovo type have been found in hoards and as single finds¹⁸⁵. Among the former is the hoard of Schitu-Pingălesti, containing a broken axe and two flat axes¹⁸⁶. In a hoard in Ostrovul Corbului, jud. Mehedinti, a total of 20 axes was found in a clay vessel¹⁸⁷.

178 Govedarica 2010b; Saveljić-Bulatović/Guštin/Hincak 2015.

179 Primas 1996, 48–52.

180 Further silver axes in a deposition in Bosnia: Born/Hansen 2001.

181 For the eponymous hoard, cf. Truhelka 1909b.

182 Catalogue Zagreb 1988, no. 221.

183 Maran 2001.

184 Kleitsas 2019.

185 Ștefan 2007.

186 Vulpe 1970, Taf. 66A.

187 Vulpe 1970, 35–37.

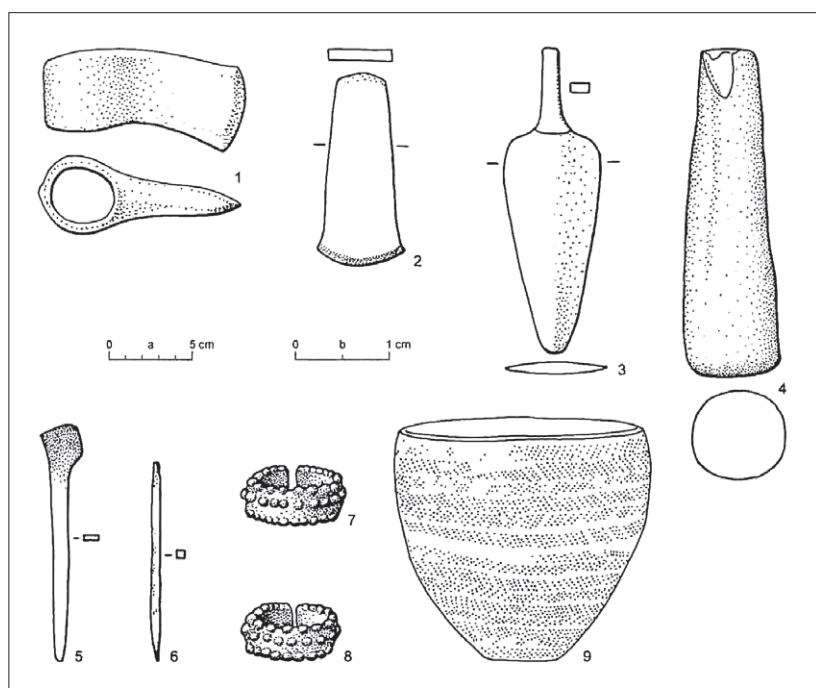
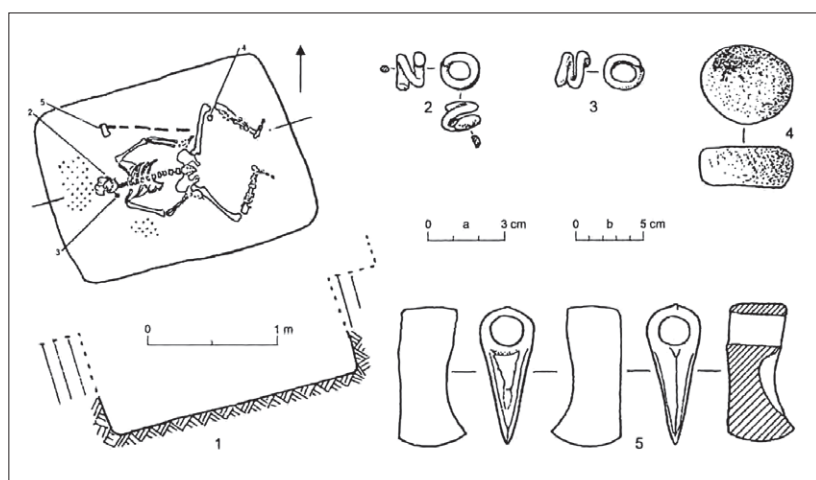

Fig. 56 Pidlissya, Ukraine. Grave.

Fig. 57 Utevkа, obl. Samara, Russian Federation. Kurgan 1.

Concentrated in the Southeastern Carpathian foothills is the distribution area of the axe type *Izvoarele* or its variant *Halânga*, to which the single deposition of an axe from *Çalugăreni*, jud. Prahova (Fig. 55) belongs¹⁸⁸.

Northeast of the Carpathians an axe of the type *Vâlcele* (Fig. 56,5) was found in grave 2 in kurgan 1 of Pidlissya on the left arm of the deceased. On both sides of the skull lay silver spiral rings (Fig. 56,2–3)¹⁸⁹. Another axe of this type was found in Kedina Gora, raion Zolotonosha, oblast Cherkassy¹⁹⁰.

East of the Carpathians axes of the *Kozarac* type seem to be absent in graves of the Yamnaya Culture. Axes from graves of the developed Yamnaya Culture in the middle Volga region represent a separate type. They are compact axes, but in contrast to the older axes of the Caucasus they are much narrower. One example is from tomb 1 (Fig. 57,1) in kurgan 1 in Utevkа, dated between 2800 and 2500 BCE. The metal ensemble includes a shaft-hole axe, a dagger, a flat axe and an awl¹⁹¹. Two small golden rings again indicate the high social status of the deceased. Also the 14C data for grave 4 in kurgan 8 of Tamar-Utkul, which contained a tool set consisting of a shaft-hole axe, a flat axe, a chisel and a dagger, confirms this dating¹⁹². In the necropolis of Pavlovsk, south of Voronezh, with 175 graves, grave 4 of kurgan 31 contained an axe, a flat axe, a chisel, a silver spiral ring and a clay vessel with pointed bottom¹⁹³. A shaft-hole axe of the same type was found in Koltuvanka¹⁹⁴. Axes of this type lead typologically to those of the *Fatyanovo* and *Abashevo* cultures¹⁹⁵.

In the North Caucasus, the end of the *Maikop-Novosvobodnaya* Culture was accompanied by a massive decline in the number of axes found in graves. Kurgan 1 of *Il'inskiĭ*, excavated by Aleksei Kalmykov and published together with Sergei N. Korenevskii, is one of the rare examples of a Yamnaya burial that contained a metal axe¹⁹⁶. In the central grave (grave 5) lay a 45–55-year-old man, on whose left side the axe (Fig. 58,2), a bronze arrowhead and 11 stone arrowheads and a lump of ochre were found. Next to it was the burial of a 25–35-year-old man and a 9–10-year-

188 Preda/Frinculeasa 2015.

189 Bratchenko/Klochko/Soltis 2000.

190 Klochko 2006.

191 Anthony 2007, 335, Fig. 13,9; Morgunova 2014, 192, Fig. 94.

192 Morgunova 2014, 190, Fig. 92,6–14; Morgunova/van

der Plicht 2013 (Tamar-Utkul VIII,4/1: GrA-54382: 4165±35; Tamar-Utkul VIII,4/1: Poz-47845: 4200±90).

193 Sinyuk 1983, 23, Fig. 8,5–10; Morgunova 2014, 187, Fig. 89.

194 Morgunova 2014, 196, Fig. 95,5.

195 Kuzmina 2003.

196 Kalmykov/Korenevskii 2001.

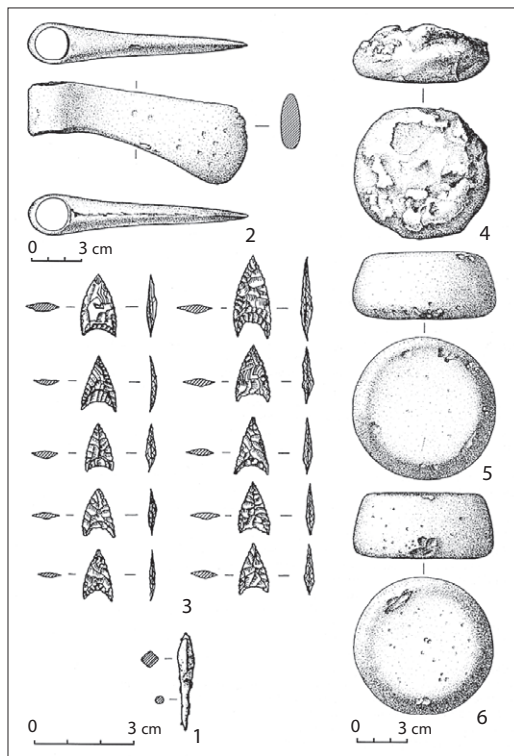

old girl, in which two round anvils of stone were found. The published 14C date gives in the 2-sigma range 2864–2474 calBCE. The authors have already referred to a very similar axe from kurgan 6, grave 2 of Bichkin-Buluk in Kalmykia. In this grave also two silver temple rings were found. The axe does not represent the Maikop-Vâlcele type and therefore cannot be used as evidence for a dating of this type beyond the middle of the 3rd millennium BCE. On the contrary, the tomb is an important proof that in the Caucasus, too, the formal change of axes from compact and massive types to more slender forms with a shortening of the shaft hole occurred.

The axe from Velikent, kurgan III, tomb 11 (Fig. 59) is “massive, archaic”, as Kaiser notes, but belongs neither to the Maikop-Vâlcele type nor to the Fajsz type. Perhaps it is a younger axe of the type Corbasca with a separate socket. With

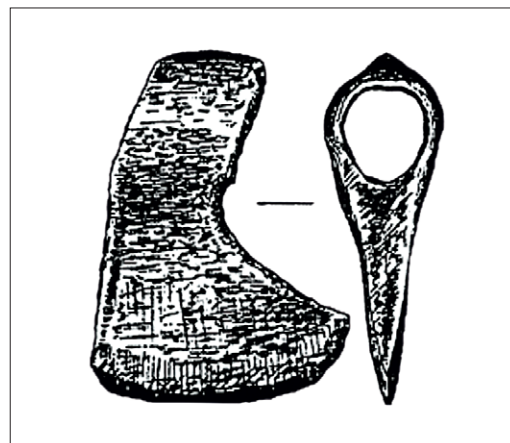

Fig. 58 Il'inskiĭ, obl. Stavropol, Russian Federation. Kurgan 1.

Fig. 59 Velikent, Dagestan, Russian Federation. Kurgan III, tomb 11.

this axe, Gernez defines his own type, which is characteristic of Dagestan (Type H 2.M.a). The calibrated 14C age gained from the wood of the axe handle – 2851–2367 calBCE – fits to the other grave goods of the catacomb grave period¹⁹⁷.

In the South Caucasus several hoards were deposited during the first half of the 3rd millennium BCE. Two hoards from western Georgia were recently catalogued by Joni Apakidze¹⁹⁸. They include the hoard of Saqasria, discovered in 1984, with two shaft-hole axes (Fig. 60), and the hoard of Zeda Ilemi, discovered in 1979, with two bronze axes (Fig. 61) and an ingot (Fig. 62). Both sites are located on the left bank of the River Dzirula. The finds were first published and presented in drawings in the work of Irina Gambashidze on metal finds of the 6th–3rd millennium BCE in Georgia¹⁹⁹. The two axes from Ilemi and one of the axes from Saqasria are characterized by a slender form. The shaft-hole socket is set off from the blade by a weak heel. They belong to group I in the scheme of Gambashidze and others²⁰⁰. In Georgia, comparable axes can still be found in the early Kurgan Culture, for example in Martkopi, kurgan IV²⁰¹. A shaft-hole axe and a group of other bronze items also belonging to this time horizon come from the only recently discovered grave of Hasansu (Fig. 63) in Azerbai-

197 Kohl/Gadzhiev/Magomedov 2002, 536–539, Fig. 11.

198 Apakidze/Hansen 2019. The project is concerned with cataloguing hoards of the 2nd and early 1st millennium BCE.

199 Gambashidze *et al.* 2010, 380–381, Pl. 27; a bronze shaft-hole axe in the hoard of Saqasria is missing. For

the metal analyses from Zeda Ilemi, cf. Kvirkvaia/Jibladze 2019, 55.

200 Gambashidze *et al.* 2010, 154; Orjonikidze 2015, Pl. 6.

201 Japaridze 1991, 141, Fig. 44,1, Pl. XXI,1; Japaridze 1998, 24, Fig. 12, Pl. 24; Kvirkvaia/Jibladze 2019, 53.

Fig. 60 Saqasria, Georgia.
Hoard.



Fig. 61 Zeda Ilemi, Georgia.
Hoard.



Fig. 62 Zeda Ilemi, Georgia.
Hoard.



jan, which dates to the first half of the 3rd millennium BCE²⁰².

The broken axe in the hoard of Saqasria belongs to a type common in the South Caucasus, which is characterized by a long thin socket and a curved blade widening towards the cutting edge²⁰³. Comparable axes (Fig. 64) are known in western Georgia, especially in the tombs of Sachkhere²⁰⁴. They are found there together with slen-



Fig. 63 Hasansu, Azerbaijan.
Grave.

202 Müseyibli/Axundova/Ağalarzadə 2012.

203 Group II of axes with a longer socket: Gambashidze *et al.* 2010, 155–156.

204 Japaridze 1961, 123, 129, Fig. 23,1; Pkhakadze 1993, Pls. XVI,1; XVII,1; XVIII.



Fig. 64 Sachkhere, Georgia. Shaft-hole axes: the uppermost axe is 22.2 cm long.

der flat axes, daggers with a grip tang as well as daggers with ornamented full grip, lance points, stone arrowheads as well as pins with large T-shaped or volute-shaped heads and clay vessels of the late Kura-Araxes Culture. The tombs of Sachkhere have been excavated by various researchers since the beginning of the 20th century, but a detailed publication of these excavations is still lacking²⁰⁵. Of the approximately 35 axes from Sachkhere only a few have been undergone chemical analysis. However, they seem to consist regularly of copper-arsenic alloys. The finds from Sachkhere represent a time horizon that can be dated before the appearance of the kurgan cultures Martkopi and Bedeni, i.e. before about 2500 BCE²⁰⁶. There are no 14C datings from Georgian find contexts available for a more exact chronological classification, which is why the chronological relationship of these groups is still in discussion²⁰⁷.

The finding of a comparable axe (*Fig. 65*) from the Lysogorskaya-6 necropolis, located

between Pyatigorsk and Georgievsk in the Stavropol krai, is therefore all the more important²⁰⁸. Kurgan 3 measured 7.2 m in height and 50 or 64 m in diameter. It was the largest hill in the vicinity. Grave 4 is the only Bronze Age burial, while graves 1–3 are of the Iron Age. Found next to the grave pit were two cattle skulls, which can be interpreted as the symbol for a team of draft animals. The deceased man lay on his back in the wooden chamber. The bronze grave goods were placed on wooden supports. They included the axe, a flat axe, two daggers and a small (now restored) bronze vessel with spiral decoration. The outstanding find is a 38-cm long all-metal driving stick ('oxgoad'), which is a unique piece. Among the metal findings is also a small gold ring. The deceased in grave 4 was undoubtedly a socially prominent person buried with exceptional grave goods. The gold ring can easily be understood as an indicator of status. The bronze vessel is indicative not only of its owner's access to technically innovative products, but also the

205 Japaridze 1961, 122–140.

206 Tchabashvili/Bastert-Lamprichs/Giemsch 2018, 308, Figs. 6,1–3; 7,1–3.

207 Kavtaradze 1981, 95; Orjonikidze 2015, 6–7.

208 Korenevskii/Berezin/Gabuev 2018, Fig. 6,4.

Fig. 65 Lysogorskaya, obl. Stavropol, Russian Federation. Necropolis 6. Axe.

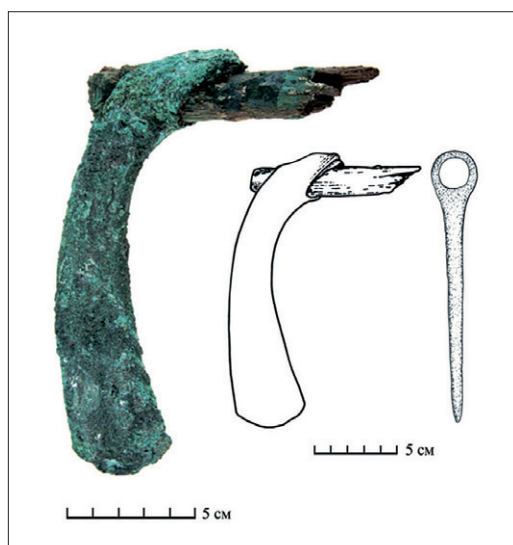

Fig. 66 Enguri River, Svanetia, Georgia. Axes.

need for an extraordinary vessel from which special, perhaps intoxicating, drinks were consumed. The cattle team and the driving stick show the gentleman as the owner of a chariot. The bronze driving stick is a weapon that could

also be used to ‘drive’ people. The axe is probably an imported product from the South and underlines the man’s long-range connections. In contrast to what is presented by Korenevskii and others, the dating of the grave can refer not only to typological estimates, but also to a concrete 14C date from this grave, which we have published in the context of our DNA study²⁰⁹. The date falls in the time between 2863–2581 calBCE (4122±23BP, MAMS-29825). This confirms the dating of the Sachkhere type axes before the time of the kurgans of Martkopi and Bedeni. The distribution of the axes is concentrated in Georgia, but there are also isolated cases north of the Caucasus.²¹⁰ A fragmented piece comes from the region around Sumi in northeastern Ukraine.²¹¹

The two hoards from Saqasria (Fig. 60) and Zeda Ilemi (Figs. 61–62) prove the custom of the deposition of hoards in western Georgia in the first half of the 3rd millennium BCE²¹². Other possible hoards are from Zahesi, Zemo Avchala (lancehead and shaft-hole axe)²¹³, Medshri-shevi, Gori district (two shaft-hole axes)²¹⁴ and Gufta, the site “Mashiv Uiati”, Tskhinvali district (two axes)²¹⁵. Of course, the numerous individual finds of such axes, which originate from destroyed graves as well as from hoard depositions, must also be included in the analysis. Only recently have axes from the Enguri River in Svanetia been published, among them an axe of the Maikop and Sachkhere type (Fig. 66)²¹⁶. This means that the custom of depositions in rivers, which is relatively poorly documented in Eastern Europe, was already practised in the Caucasus during the 3rd millennium BCE.

Hoards of the second half of the 3rd millennium BCE

In the Carpathian Basin, in the second half of the 3rd millennium BCE, the characteristic axes are of the type Pätulele²¹⁷. On the occasion of two

209 Wang *et al.* 2019, supplementary information.

210 Korenevskii 1981.

211 Klochko/Kozymenko 2017, 92, Fig. 8.

212 Apakidze/Hansen 2019.

213 Gambashidze *et al.* 2010, Pl. 15,236–237.

214 Gambashidze *et al.* 2010, Pl. 16,242–243.

215 Gambashidze *et al.* 2010, Pl. 17,257–258.

216 Kvitsiani/Jibladze 2015, 120, Pl. 3,3.

217 Vulpe 1970, 37–39.

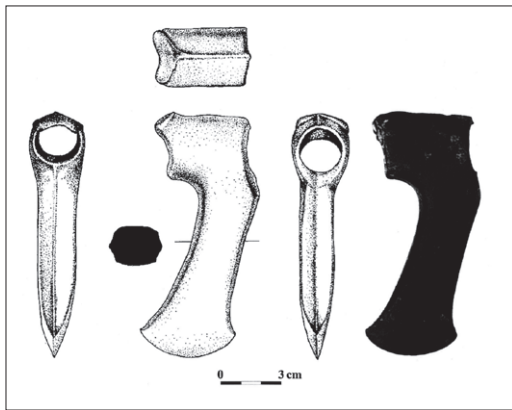
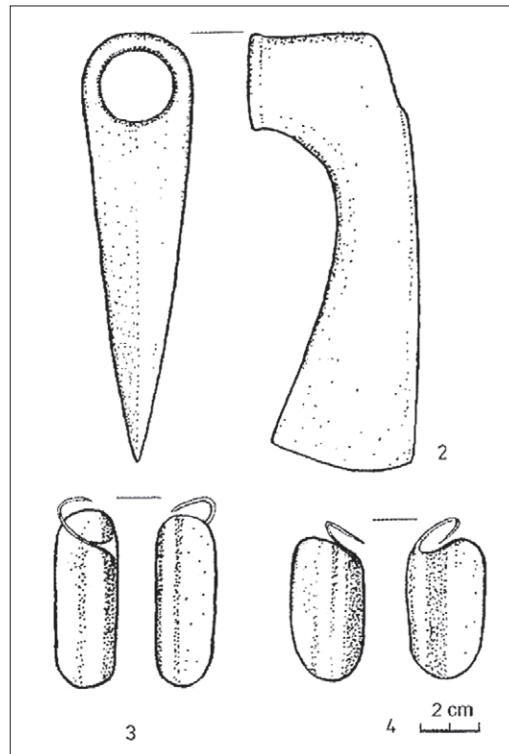

Fig. 67 Niculițel, jud. Tulcea, Romania. Axe of Pătulele type.

Fig. 68 Mezhyhircsi (Polish: Mezyhirci), obl. Galich, Ukraine. Hoard.



new finds Sorin Ailincăi has studied this type anew and suggests a dating between 2400 and 2200 BCE²¹⁸. In the Carpathian Basin, Pătulele-type axes were solely deposited as single or multi-piece hoards (Fig. 67). Some hoards with these axes are also known in Bulgaria. One axe belongs to a hoard in the Greek Thebes, which can probably be dated to the phase Early Helladic III²¹⁹. Another axe of this type comes from a small hoard found in the settlement of Daskalio, near the Cyclades island of Keros. It is attributed to phase C, which is dated to the 24th century BCE²²⁰.

East of the Carpathian Mountains are a number of hoards with shaft-hole axes. The find of Mezhyhircsi (Polish: Mezyhirci), oblast Galich in the Carpathians (Fig. 68) consists of an axe with two gold earrings in the shaft-hole socket²²¹. The axe was found in 1998 under circumstances, which unfortunately cannot be reconstructed. It is attributed to the Stublo type, which is considered a late variant of the Kozarac-type axes. There are differences in both the contour of the blade back and the shape of the shaft-hole. Bătora already connected the two golden earrings with very similar west European earrings of the Bell Beaker period²²². These golden rings can be found throughout the Atlantic area. Jay J. Butler had already paralleled the Western European rings

with Eastern Central European finds in 1956 and suggested a chronological intertwining of the Bell Beakers in the Netherlands with the period Bronze Age A1 (according to Paul Reinecke) in Poland²²³. In 2004 Brendan O'Connor discussed the Central and Eastern European comparison finds again²²⁴. Like Butler, he also included the willow-leaf-shaped rings of the Early Bronze Age Mierzanowice Culture in his considerations. There may be a very general connection here, but in my opinion there is actually no reason for these formal-typological considerations. The gold earrings and the willow leaf-shaped rings differ in material and in the principle of suspension. The only really similar piece for comparison seems to be from the Rusiliv burial mound, oblast Ternopil. For the dating of the golden rings of Mezyhirci this means that they can be paralleled with the Bell Beaker period.

218 Ailincăi 2003–2005; Ailincăi 2009.

219 In addition to the shaft-hole axe, the hoard contains a double axe, two flat axes, a chisel and the fragment of a chisel (Maran 1989). For a comprehensive discussion of the shaft-hole axes, see now Kleitsas 2019.

220 Georgakopoulou 2013, 673–677.

221 Machnik/Tkaczuk 2003, 484–485 with illustrations.

222 Bătora 2003, 25.

223 Butler 1956.

224 O'Connor 2004.

Fig. 69 Stubło (Stebliwka), Poland. The two axes from the hoard.



Based on 14C dates, the Atlantic finds are dated to the 24th–23rd century BCE²²⁵. Two decorated gold earrings derive from the well-known grave of the “Amesbury Archer”, which held probably the most extensive grave equipment of the Bell Beaker Period outside the Iberian Peninsula. It is dated to the 23rd century BCE²²⁶.

The axe and the two gold rings formed an ensemble, whose unity should be preserved. The axe can be understood here as the container for the gold sheet. A piece of metal was also found jammed into the shaft socket of one of the Saqasria axes (Fig. 60). This form of deposition has been known since the Copper Age. For example, the hoard of Szeged “Sziller” contained a broken axe, in whose shaft-hole three chisels of different shapes were wedged²²⁷. The axe-adze dates the find to the 5th millennium BCE. The number of such finds only increased significantly in the Late Bronze Age, when the breaking of objects became a special mode of hoard deposition²²⁸. These are small objects or fragments which were inserted into socketed axes or the sockets of lanceheads. One can understand these small metal ensembles as meaning that two or more objects should be deposited together, which had previously been dedicated together. Another interpretation is that the objects that were stuck together were intended to prevent the axe blade

from being re-mounted and thus from being re-used.

The Stubło variant was last compiled by Klochko²²⁹. The eponymous find of Stubło (Stebliwka) in Volhynia contained two axes (Fig. 69) and several decorative ornaments, including willow leaf-shaped pendants²³⁰. The eponymous axe has a larger shaft-hole socket compared to the Kozarac axes, which is slightly thickened only at the mouth of the socket. The second strongly curved axe points back to the Caucasus. Korenevskii counts it to his type Faskau.²³¹

In the North Pontic steppe area several hoards with shaft-hole axes are known: Kolotaevka with several shaft-hole axes of different shapes, Rybakovka with shaft-hole axes and flat axes, Skakun with a shaft-hole axe and a chisel, and Oleksandrivka and Privol'noe with a shaft-hole axe, a flat axe and two daggers. The compilation of these axes (Fig. 70) by Korenevskii shows the range of variation among these Middle Bronze Age axe forms²³².

The hoard of Ureki, dist. Osurgeti (Figs. 71–72) in western Georgia has been dated to the 18th–16th century BCE or even considered younger.²³³ Several components of the find were brought to the museums at different times, but the hoard seems to be a closed find. According to the research of Joni Apakidze, in 1938 some objects of the hoard were found by a student under an old lime tree. In 1941 19 axes and three adzes were found on the same spot under the lime tree. In 1945 a pupil also found some hoes and a “scraping knife” at the same place. The hoard consists of 23 bronze axes, 7 bronze adzes and two “halberd blades”²³⁴. Some of the axes from Ureki (Fig. 71) can be compared with the shaft-hole axes of the type Pätulele²³⁵. The shape of the remaining shaft-hole axes (Fig. 72) does not contradict this dating. Two shaft-hole axes with strongly curved blade can also find comparisons in Southeastern Europe²³⁶. The adzes do not

225 Fitzpatrick *et al.* 2016, 44.

226 Fitzpatrick 2019, 327, Fig. 7.

227 Pulszky 1884, 22–24, Fig. 1,1.

228 Hansen 1996–1998; Dietrich 2014; Dietrich/Mörtz 2019.

229 Klochko 2012, 396, Fig. 1.

230 Antoniewicz 1929.

231 Korenevskii 1981.

232 Korenevskii 1974.

233 Reinhold 2005.

234 Koridze 1965, Pl. 1-2; 3,2–7.

235 Vulpe 1970, 37–39; Ailincăi 2009.

236 Chernykh 1978, Pl. 24,1.

Fig. 70 Axes of the second half of the 3rd millennium BCE.

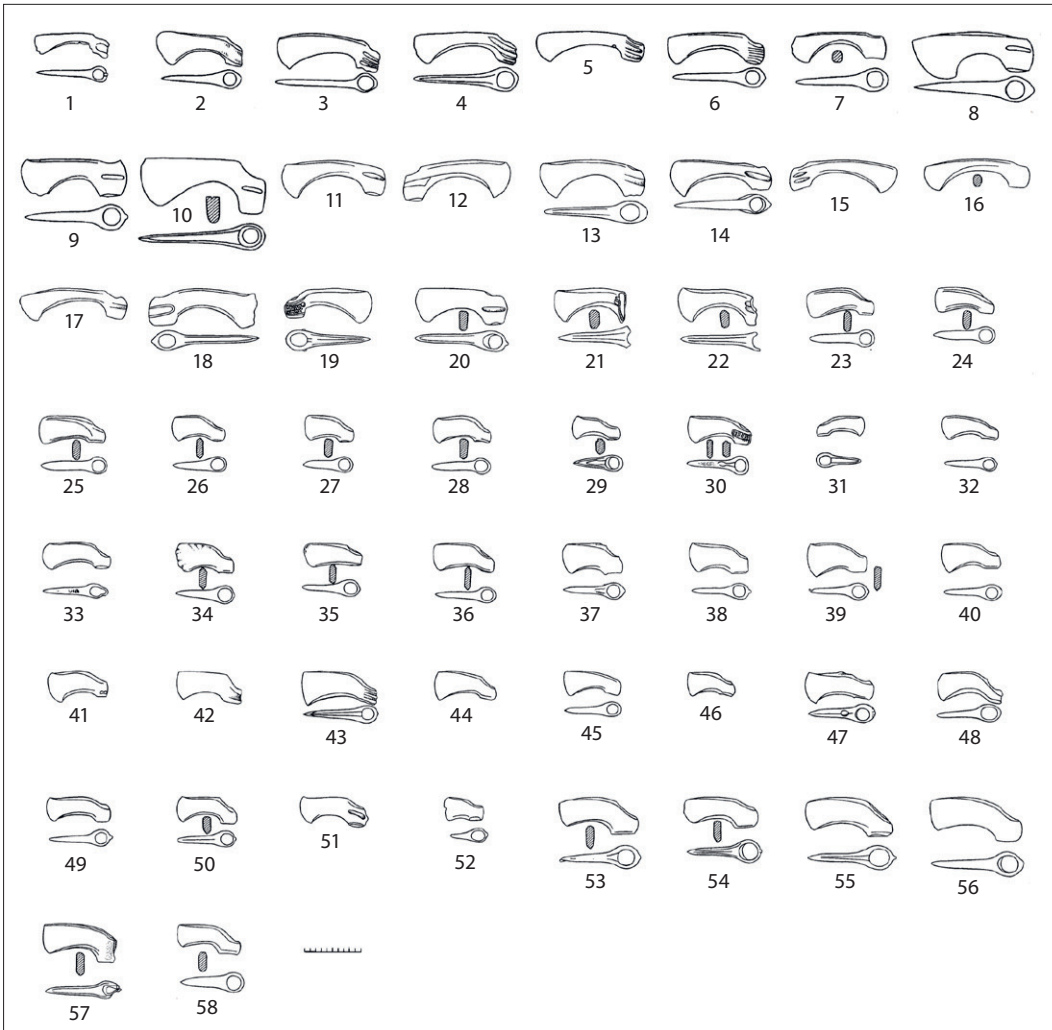
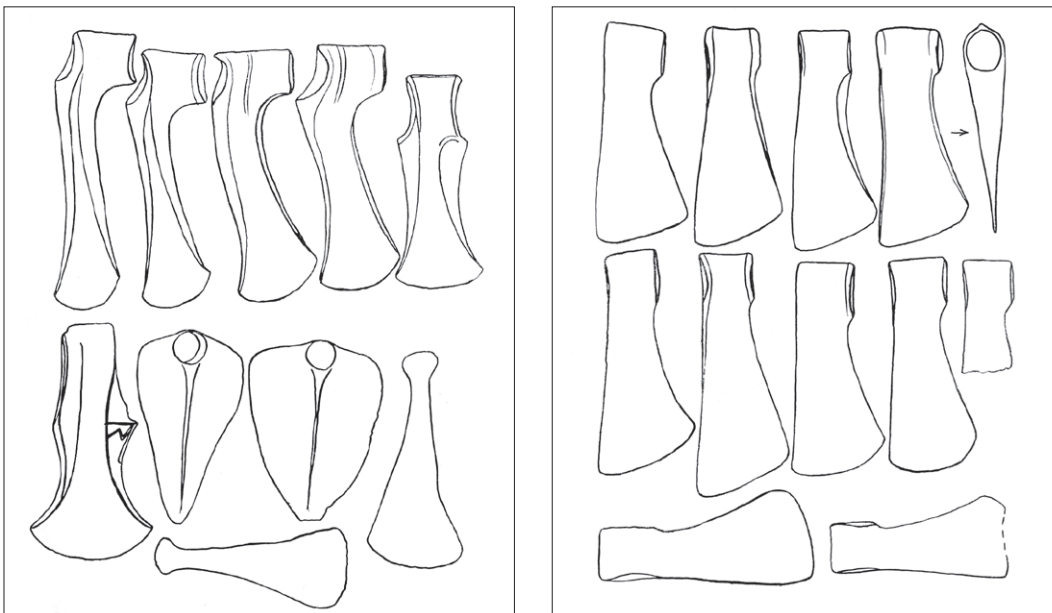

Fig. 71 Ureki, Osurgeti district, Georgia. Hoard.

Fig. 72 Ureki, Osurgeti district, Georgia. Hoard.



contradict the dating into the 3rd millennium BCE either. Special objects are the two “halberd blades”, which are probably Egyptian flat axes that were deposited in graves as small tools, especially in the 4th dynasty²³⁷.

Conclusions

The history of the axes can only be described in broad outlines so far, as only few of them originate from datable find contexts. Again and again there are gaps in tradition. This is primarily due to the different norms of deposition (*Fig. 73*). Whereas in the Tisza Plain axes in graves could have served as grave goods, in the eastern Carpathian Basin they were deposited in hoards ever since the 5th millennium BCE without exception. East of the Carpathians, hoards also predominate, but there are also few axes in graves of the Yamnaya Culture. In the North Caucasus, however, they were used exclusively as grave goods. In the South Caucasus, hoards as well as graves with axes are known from the early 4th millennium BCE onwards.

In burial rites, the axe as a funerary object was bound to the highest grave furnishings. This is true for the Carpathian Basin in the 5th millennium BCE with graves of the Tiszapolgár and Bodrogkeresztúr cultures as well as for the Caucasus with the Maikop and Novosvobodnaya graves. Early Bronze Age graves often contain other exclusive metal objects, such as bronze vessels, flat axes and daggers. Gold and silver offerings are also common. The axe was a tool on the one hand and a weapon on the other. In the graves of the powerful it was an expression and signal of the firm will to defend social supremacy.

In the North Caucasus metal tools were reserved for burials of the leading social group. This also allows a social evaluation of the axes placed in hoards or as single objects. The depositions of single or multiple copper and bronze objects was also not a mass phenomenon, but one that was tied to the socially privileged. The

hoard in the 5th–3rd millennium BCE can be understood as a medium of social privilege that was analogous to the grave.

Since the 5th millennium BCE, hammer axes and axe-adzes had been in use in the Carpathian Basin in numerous variations. These spread in all directions, even to the east. The hammer axe from the grave of Ovçular Tepesi in the South Caucasus is the earliest dated find to date that proves an exchange of axes.

The spiked axes can be described as the first Caucasian metal axe form; their area of distribution ranges from Iranian Azerbaijan to the eastern edge of the Carpathians with a clear focus on Armenia and Georgia. The most reliably dated axe comes from the Tripolye settlement and can thus be dated to the second quarter of the 4th millennium BCE. This corresponds with the dating of the graves in Sé Girdan, parallel to the great kurgan of Maikop.

In this kurgan the classical shaft-hole axe was present for the first time, at ca. 3700/3600 BCE, which can be described as a Caucasian further development of the spiked axe. This innovation is to be seen in the context of further developments in weapons technology, for which the earliest evidence exists in the Caucasus. This axe found its way into the Carpathian Basin, where a number of axes of the same type were deposited in hoards and as single objects. The Carpathian axes are probably local products, because they are – unlike the Caucasian axes – made of pure copper. Around about 2900 BCE these heavy unstructured axes were replaced by a new axe shape with a separated socket and a narrower blade. The Kozarac-type axe is the starting point for a varied development in Southeastern Europe, but finds no access to the area east of the Carpathians, where axes appear, whose blade is also narrower, but still retains the unstructured form. In the South Caucasus, axes of the Sachkhere type show a development of their own in the first half of the 3rd millennium BCE, which radiates into the North Caucasus. At the same time or a little later axes in the South Caucasus are connected to

237 Publication in preparation.

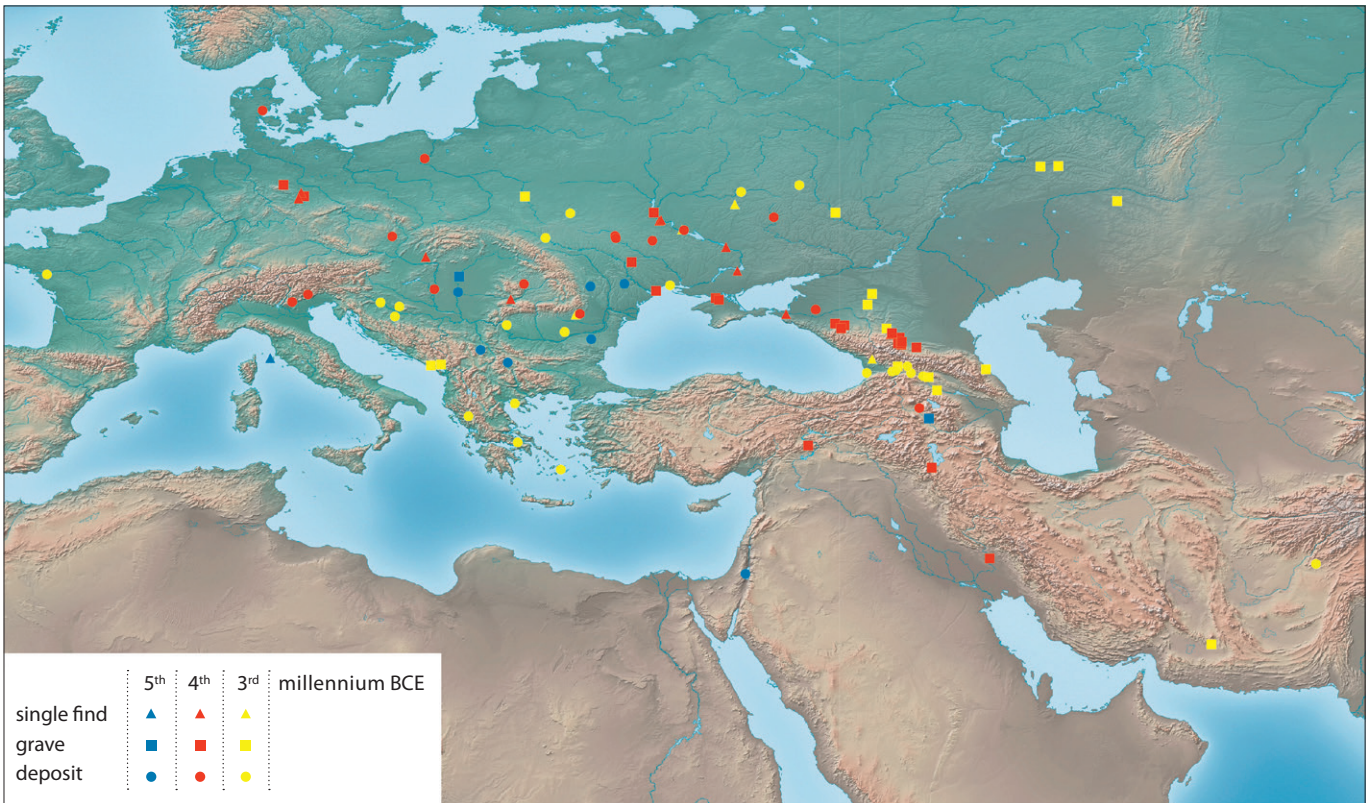

Fig. 73 Map with the most important sites mentioned in the text.

the South-East European production lines. Close similarities can also be seen in the second half of the 3rd millennium BCE.

As fragmentary as the tradition for heavy copper and bronze axes is, it is plausible for the history of innovation of the shaft-hole axe that this happened in the second quarter of the 4th millennium BCE in the Caucasus, namely in the context of the development of other new and effective weapons. The shaft-hole axe was a resounding success. It is still produced in a similar form today. Almost all the technical prerequisites had been established long before that. We can only assume that the small change with a big effect, namely the relocation of the shaft-hole to the neck, was mainly due to the improvement of the casting technique in the course of the arsenic alloying. The casting probably succeeded more effortlessly at this structurally sensitive point in particular, and the risk of breakage in this place

was reduced. For about two thousand years the shaft-hole axe became the standard armament in the Near East as well as in the North Pontic steppe region and in Southeast Europe.

Acknowledgements

This paper is part of my Advanced Grant that has received funding from the European Research Council (ERC) under the European Union's Horizon 2020 (Grant agreement No. 834616).

My gratitude to Joni Apakidze, Blagoje Govedarica, Kirsten Hellström, Barbara Helwing, Alekseï Kalmykov, Mehmet Karauçak, Sergeï Korenevskii, Sabine Reinhold, Mike Teufer and Viktor Trifonov for their provision of information, discussions and the permission to use the material. Emily Schalk was responsible for the English text.

Bibliography

Acconcia/Millett 2015

V. Acconcia/M. Millett, Il ripostiglio di San Martino e la metallurgia elbana tra Bronzo Finale e prima età del Ferro. *Rivista di Scienze Preistoriche* LXV, 2015, 217–251.

Adamczak et al. 2015

K. Adamczak/L. Kowalski/ J. Bojarski/M. Wein-kauf/A. Garbacz-Klemka, Eneolithic Metal Objects Hoard from Kaldus, Chełmno Commune, Kujawsko-Pomorskie Voivodeship. *Sprawozdania Archeologiczne* 67, 2015, 199–219.

Ailincăi 2003–2005

S.C. Ailincăi, Un topor de bronz descoperit la Niculițel (jud. Tulcea). *Studii și Cercetări de Istorie Veche și Arheologie* 54–56, 2003–2005, 271–277.

Ailincăi 2009

S.C. Ailincăi, A new Bronze Age axe discovered in Northern Dobruja. *Peuce* 7, 2009, 49–56.

Anthony 2007

D.W. Anthony, The Horse, the Wheel and Language. How Bronze Age Riders from the Eurasian Steppes Shaped the Modern World (Princeton/Oxford 2007).

Antoniewicz 1929

V. Antoniewicz, Der in Stublo in Wolhynien aufgefundene Bronzeschatz. *Eurasia Septentrionalis Antiqua* 4, 1929, 135–148.

Apakidze/Hansen 2019

J. Apakidze/S. Hansen, Zwei Horte mit Schaflochhäxten vom Ende der Frühbronzezeit aus Westgeorgien. *Das Altertum* 64, 2019, 271–290.

Artioli et al. 2013

G. Artioli/I. Angelini/P. Nimis/A. Addis/I.M. Villa, Prehistoric copper metallurgy in the Italian Eastern Alps: recent results. *Historical Metallurgy* 47, 2013, 51–59.

Băjenaru 2010

R. Băjenaru, Between Axe and Dagger: Early Bronze Age Weaponry in the Lower Danube Area. In: R. Băjenaru/G. Bodi/C. Opreanu/V.V. Zirra (eds.), *Recent Studies in the Past and Present, vol. I: Human Heritage and Community: Archaeology in the Carpathians and Lower Danube Area from Prehistory to the Early Medieval Age*. *Transylvanian Review* 19, Supplement 5,1 (Cluj-Napoca 2010) 151–162.

Băjenaru/Frînculeasa 2014

R. Băjenaru/A. Frînculeasa, A new Baniabic type axe from Southern Romania. In: C. Schuster/O. Cirstina/M. Cosac/G. Murătoreanu (eds.), *Proceedings of the 12th International Congress of Thracology “The Thracians and their Neighbors in the Bronze and Iron Ages”, Târgoviște, 10th–14th September 2013* (Târgoviște 2014) 13–16.

Bar-Adon 1980

P. Bar Adon, The Cave of the Treasure. The Finds from the Caves in Nahal Mishmar (Jerusalem 1980).

Batchaev/Korenevskii 1980

V.M. Batchaev/C.H. Korenevskii, Находка оригинального топора в майкопском погреб-

ении у с. Лечинкай. Краткие сообщения Института археологии (КСИА) 161, 1980, 79–83.

Bátora 2003

J. Bátora, Kupferne Schaflochhäxte in Mittel-, Ost- und Südosteuropa (Zu Kulturkontakten und Datierung – Äneolithikum/Frühbronzezeit). *Slovenská Archeológia* 51, 2003, 1–38.

Baudouin 1923

M. Baudouin, Neuf haches plates et une pointe de javeline en cuivre trouvées en Loire près Trentemoult (L.-A.). *Bulletin de la Société Préhistorique Française* 20, 1923, 326–328.

Becker 2013

K. Becker, Transforming Identities – New Approaches to Bronze Age Deposition in Ireland. *Proceedings of the Prehistoric Society* 79, 2013, 225–263.

Behm-Blancke 1984

M.R. Behm-Blancke, Hassek Höyük. Vorläufiger Bericht über die Ausgrabungen der Jahre 1981–1983. *Istanbuler Mitteilungen* 34, 1984, 31–149.

Bejinariu/Kadar 2003

I. Bejinariu/M. Kadar, An Early Bronze Age axe discovered in Sălaj county. In: A. Chiriac/L. Cornea/C. Ghemiș/G. Moisa (eds.), *In Memoriam Nicolae Chidioșan* (Oradea 2003) 41–51.

Beldiman/Sztancs 2000–2006

C. Beldiman/D.-M. Sztancs, Depozitele de obiecte de prestigiu aparținând culturii Cucuteni. *Studiul artefactelor din materii dure animale. Materiale și cercetări arheologice* (Serie nouă) 2000–2006, 33–74.

Belinskij/Hansen/Reinhold 2017

A. Belinskij/S. Hansen/S. Reinhold, The Great Kurgan from Nalčik. A Preliminary Report. In: E. Rova/M. Tonussi (eds.), *At the Northern Frontier of Near Eastern Archaeology*. *Subartu XXXVIII* (Turnhout 2017) 13–31.

Benešová 1956

A. Benešová, Nález měděných předmětů na Starých Zámčích v Brně-Líšni. *Pamatky Archeologické* 47, 1956, 236–244.

Bianchin Citton 2013

E. Bianchin Citton, Aspetti funerari e culturali dell'età del Rame nel Veneto centro-orientale. In: R.C. de Marinis (ed.), *L'età del rame. La Pianura padana e le Alpi al tempo di Ötzi* (Roccafranca 2013) 437–449.

Bisson de la Roque/Contenau/Chapouthier 1953

F. Bisson de la Roque/G. Contenau/F. Chapouthier, *Le Trésor de Tôd*. *Documents de Fouilles de l'Institut Français d'Archéologie Orientale du Caire XI* (Le Caire 1953).

Blažek/Hansen 1997

J. Blažek/S. Hansen, Die Hortfunde von Saběnice in Nordwest-Böhmen. *Beiträge zur Ur- und Frühgeschichte Nordwestböhmens* 4 (Most 1997).

Borić 2009

D. Borić, Absolute Dating of Metallurgical Innovations in the Vinča Culture of the Balkans. In: T.L. Kienlin/B. Roberts (eds.), *Metals and*

society. *Studies in honour of Barbara S. Ottaway* (Bonn 2009) 191–245.

Born/Hansen 2001

H. Born/S. Hansen, *Helme und Waffen in Alt-europa* (Mainz 2001).

Boroffka 2009

N. Boroffka, Simple technology: casting moulds for axe-adzes. In: T.L. Kienlin/ B. Roberts (eds.), *Metals and society*. *Studies in honour of Barbara S. Ottaway* (Bonn 2009) 246–257.

Bratchenko/Klochko/Soltis 2000

C.H. Братченко/В.І. Клочко/О.Б. Солтис, Металеві сокири ямної культури Середньої Наддніпрянщини. *Археологічний літопис Лівобережної України* 1–2, 2000, 8–14.

Brummack in prep.

S. Brummack, Vergleichende Studien zum sozialen Individuum zwischen Zentralbalkan und Westschwarzmeerküste im Lichte der Gräber (Dissertation FU Berlin, in preparation).

Butler 1956

J.J. Butler, The Late Neolithic gold ornament from Bennekom, vol. II: The affiliations of the Bennekom ornament. *Palaeohistoria* 5, 1956, 59–71.

Casal 1961

J.-M. Casal, Fouilles de Mundigak. *Mémoires de la Délégation Archéologique Française en Afghanistan* 17 (Paris 1961).

Casanova et al. 2015

M. Casanova/G. Pierrat-Bonnefois/V. Quenet/V. Danrey/D. Lacambre, Lapis Lazuli in the Tôd treasure: a new investigation. In: P. Koisoulis/N. Lazaridis (eds.), *Proceedings of the Tenth International Congress of Egyptologists*. University of the Aegean, Rhodes 22–29 May 2008 (Leuven/Paris/Bristol 2015) 1619–1640.

Catalogue Bochum 2005

Ü. Yalcin/C. Pulak/R. Slotka, *Das Schiff von Ulu Burun. Welthandel vor 3000 Jahren*. Katalog der Ausstellung des Deutschen Bergbau-Museums Bochum vom 15. Juli 2005 bis 16. Juli 2006 (Bochum 2005).

Catalogue St. Petersburg 2013

Ю.Ю. Пиотровский (ed.), *Бронзовый Век. Европа без Границ. IV – начало I тысячелетия до новой эры / Bronzezeit. Europa ohne Grenzen*. 4.–1. Jahrtausend v. Chr. (Санкт-Петербург 2013) 291–654.

Catalogue Zagreb 1988

A. Durman (ed.), *Vučedol – treće tisućljeće p. n. e. / Vučedol – three thousand years B.C.* (Zagreb 1988).

Chantre 1873

E. Chantre, *Fonderies ou cachettes de l'âge du bronze dans la Côte-d'Or et la Savoie*. *Matériaux pour l'histoire primitive et naturelle de l'Homme* 4, 1873, 52–54.

Chantre 1875–76

E. Chantre, *Études paléoethnologiques dans le Bassin du Rhône – Recherches sur l'origine de la métallurgie en France I–III* (Paris 1875–1876).

Chechenov 1973

И.М. Чеченов, Нальчикская подкурганная гробница (Нальчик 1973) 1–62.

- Chechenov 1984**
И.М. Чеченов, Вторые курганные группы у селений Кишпек и Чегем II. Археологические исследования на новостройках Кабардино-Балкарии (Нальчик 1984) 164–253.
- Chernakov 2018**
D. Chernakov, A New-Found Hoard of Chalcolithic Heavy Copper Tools from Northeastern Bulgaria. *Archaeologia Bulgarica* 22, 2, 2018, 1–13.
- Chernykh 1966**
Е.Н. Черных, История древнейшей металлургии восточной Европы (Москва 1966).
- Chernykh 1978**
Е.Н. Черных, Горное дело и металлургия в древнейшей Болгарии (София 1978).
- Chernykh 1992**
E.N. Chernykh, Ancient Metallurgy in the USSR. The Early Metal Age (Cambridge 1992).
- Cochavi-Rainey 1999**
Z. Cochavi-Rainey, Royal Gifts in the Late Bronze Age Fourteenth to Thirteenth Centuries B.C.E. (Beer-Sheva 1999).
- Csányi/Raczky/Tárnoki 2010**
M. Csányi/P. Raczky/J. Tárnoki, Das kupferzeitliche Gräberfeld von Rákóczi-falva-Bagiföld in Ungarn. *Das Altertum* 55, 2010, 241–270.
- Dani 2013**
J. Dani, The Significance of Metallurgy at the Beginning of the Third Millennium BC in the Carpathian Basin. In: V. Heyd/G. Kulcsár/V. Szeverényi (eds.), Transitions to the Bronze Age. Interregional Interaction and Socio-Cultural Change in the Third Millennium BC Carpathian Basin and Neighbouring Regions. *Archaeolingua* 30 (Budapest 2013) 203–232.
- Dergachev 1998**
В.А. Дергачев, Кэбунский клад (Кишинев 1998).
- Dergačev 2002**
V.A. Dergačev, Die äneolithischen und bronzezeitlichen Metallfunde aus Moldavien. *Prähistorische Bronzefunde* XX,9 (Stuttgart 2002).
- Dergačev 2016**
V. Dergačev, Noi depozite de piese metalice ale culturii Cucuteni-Tripole din regiunea Nistrului mijlociu (Ucraina). *Arheologia Moldovei* 39, 2016, 179–194.
- Dergachev 2018**
В. Дергачев, Топоры типа Баниабик-Майкоп-Новосвободная. *Историографический обзор. Revista Arheologică, serie nouă* 14, 2018, 13–32.
- Diaconescu 2014**
D. Diaconescu, New remarks about the typology and the chronology of the Pločnik and Čoka copper hammer-axes. In: W. Schier/F. Draşovean (eds.), The Neolithic and Eneolithic in Southeast Europe: New Approaches to Dating and Cultural Dynamics in the 6th to 4th Millennium BC (Rahden/Westf. 2014) 221–241.
- Didier/Mutin 2013**
A. Didier/B. Mutin, La production céramique protohistorique du Makran pakistanais la compréhension des relations indo-iraniennes. World Congress, 1–7 September, Burgos, Spain. Volume 6, Session B36 (Oxford 2016) 37–54.
- Frangipane/Palmieri 1988**
M. Frangipane/A. Palmieri, A Protourban Centre of the Late Uruk Period. *Origini* 12, 1988, 287–454.
- Frost 2008**
L. Frost, Vognserup Enge – Et offerfynd med kvindesmykker fra den ældre bronzealder. *Aarbøger for Nordisk Oldkyndighed og Historie* 2008, 7–58.
- Frost 2013**
L. Frost, River finds – Bronze Age depositions from the River Gudenå, Denmark. *Germania* 91, 2013, 39–88.
- Furholt 2013**
M. Furholt, Die Datierung der Höhensiedlung Hlinsko im Kontext der Boleráz-Gruppe Mährens. *Přehled výzkumů* 54, 1, 2013, 83–97.
- Gambashidze et al. 2010**
I. Gambashidze/G. Gogotschuri/K. Kachiani/I. Japaridze, Udzelesi metalurgia da samto saqme saqartveloshi dzv. ts. VI–III atatsleulbschi (Ancient metallurgy and mining in Georgia in the 6th to 3rd millennia BC) (Tbilisi 2010).
- Georgakopoulou 2013**
M. Georgakopoulou, Metal Artefacts and Metallurgy. In: C. Renfrew/O. Philaniotou/N. Brodie/G. Gavalas/M.J. Boyd (eds.), The settlement at Dhaskalio. The sanctuary on Keros and the origins of Aegean ritual practice: the excavations of 2006–2008, vol. I (Cambridge 2013) 667–692.
- Gernez 2007**
G. Gernez, L'armement en métal au Proche et Moyen-Orient: des origines à 1750 av. J.-C. *Sciences de l'Homme et Société. Université Pantheon-Sorbonne – Paris I, 2007. Français.* <tel-00339404>
- Gernez 2017**
G. Gernez, Les armes du Proche Orient. Des origines à 2000 av. J.-C. (Paris 2017).
- Gilead/Gošić 2014**
I. Gilead/M. Gošić, Fifty Years Later: A Critical Review of the Stratigraphy, Chronology and Context of the Nahal Mishmar Hoard Mitekufat Haeven. *Journal of the Israel Prehistoric Society* 44, 2014, 226–239.
- Gimbutas 1956**
M. Gimbutas, The Prehistory of Eastern Europe. Part 1: Mesolithic, Neolithic and Copper Age Cultures in Russia and the Baltic Area (Cambridge, Mass. 1956).
- Gleirscher 2007**
P. Gleirscher, Frühes Kupfer und früher Kupferbergbau im und um den Ostalpenraum. In: M. Blečić/M. Črešnar/B. Hänsel/A. Hellmuth/E. Kaiser/C. Metzner-Nebelsick (eds.), *Scripta praehistorica in honorem Biba Teržan. Situla* 44 (Ljubljana 2007) 93–110.
- Godelier 1999**
M. Godelier, Das Rätsel der Gabe. Geld, Geschenke, heilige Objekte (München 1999).
- Govedarica 2010a**
B. Govedarica, Spuren von Fernbeziehungen in
- In: J. Bendezu-Sarmiento (ed.), *L'archéologie française en Asie centrale. Nouvelles recherches et enjeux socioculturels. Cahiers d'Asie centrale* 21/22 (Paris/Bichkek/Kaboul 2013) 461–486.
- Dietrich 2014**
O. Dietrich, Learning from 'Scrap' about Late Bronze Age Hoarding Practices: A Biographical Approach to Individual Acts of Dedication in Large Metal Hoards of the Carpathian Basin. *European Journal of Archaeology* 17, 2014, 468–486.
- Dietrich/Mörtz 2019**
O. Dietrich/T. Mörtz, Sockets full of scrap? Remarks on deliberate fragmentation in Late Bronze Age metal deposits in south-eastern and north-western Europe. In: D. Brandherm (ed.), *Aspects of the Bronze Age in the Atlantic Archipelago and Beyond Proceedings from the Belfast Bronze Age Forum, 9–10 November 2013. Archaeologia Atlantica – Monographie 3 (Hagen/Westf. 2019)* 281–298.
- Dobeš 2013**
M. Dobeš, Měď v eneolitických Čechách / Kupfer im Äneolithikum Böhmens (Praha 2013).
- Dunand 1950**
M. Dunand, Fouilles de Byblos II – Atlas (Paris 1950).
- Dunand 1954**
M. Dunand, Fouilles de Byblos II – Texte (Paris 1954).
- Ertekin/Ediz 1993**
A. Ertekin/I. Ediz, The unique sword from Bogazköy/Hattuša. In: M.J. Mellink/E. Porada/T. Özgüç (eds.), *Aspects of Art and Iconography: Anatolia and its Neighbors. Studies in Honor of Nimet Özgüç (Ankara 1993)* 719–725.
- Evans 1881**
J. Evans, The ancient bronze implements, weapons and ornaments of Great Britain and Ireland (London 1881).
- Evans/Roßberger 2019**
J.M. Evans/E. Roßberger, in cooperation with P. Paoletti (eds.), Ancient Near Eastern Temple Inventories in the Third and Second Millennia BCE: Integrating Archaeological, Textual, and Visual Sources. Proceedings of a Conference held at the LMU Centre for Advanced Studies, November 14–15, 2016 (Gladbeck 2019).
- Fitzpatrick 2019**
A.P. Fitzpatrick, El Arquero de Amesbury. In: G. Delibes/E. Guerra (eds.), ¡Un brindis por el príncipe! El vaso Campaniforme en el interior de la Península Ibérica (2500–2000 a. C.) (Madrid 2019) 319–338.
- Fitzpatrick et al. 2016**
A.P. Fitzpatrick/G. Delibes de Castro/E. Guerra Doce/J. Velasco Vázquez, Bell Beaker connections along the Atlantic façade: the gold ornaments from Tablada del Rudrón, Burgos, Spain. In: E. Guerra Doce/C. Liesau von Lettow-Vorbeck (eds.), *Analysis of the Economic Foundations Supporting the Social Supremacy of the Beaker Groups. Proceedings of the XVII UISPP*

- Norddeutschland während des 5. Jahrtausends v. Chr. *Das Altertum* 55, 2010, 1–12.
- Govedarica 2010b**
B. Govedarica, Grab- und Opferfunde aus dem Hügel Gruda Boljevića in Montenegro (erste Hälfte des 3. Jahrtausend v. Chr.). In: J. Šuteková/P. Pavúk/P. Kalábková/B. Kovár (eds.), *Panta Rhei. Studies on the Chronology and Cultural Development of South-Eastern and Central Europe in Earlier Prehistory. Presented to Juraj Pavúk on the Occasion of his 75th Birthday* (Bratislava 2010) 103–109.
- Govedarica 2019**
B. Govedarica, Aleksandrovka. In: S. Hansen (ed.), *e-Jahresbericht 2019 des DAI – Eurasien-Abteilung* 2019, 247.
- Govedarica/Manzura 2011**
B. Govedarica/I. Manzura, Grundzüge einer Kulturgeschichte des nordwestlichen Schwarzmeergebietes im 5. und 4. Jahrtausend v. Chr. In: E. Sava/B. Govedarica/B. Hänsel (eds.), *Der Schwarzmeerraum vom Äneolithikum bis in die Früheisenzeit (5000–500 v. Chr.)*, Bd. 2: Globale Entwicklung versus Lokalgeschehen. Internationale Fachtagung von Humboldtianern für Humboldtianer im Humboldt-Kolleg in Chişinău, Moldavien, 4.–8. Oktober 2010 (Rahden/Westf. 2011) 61–61.
- Gries 2019**
H. Gries, Votive Objects from the Temple of Aššur at Aššur. In: Evans/Roßberger 2019, 139–158.
- Hampel 1903**
J. Hampel, A M. N. Múzeumi Régiségosztály gyarapodása. *Archaeologiai Értesítő* 23, 1903, 425–447.
- Hansen 1991**
S. Hansen, Studien zu den Metalldeponierungen während der Urnenfelderzeit im Rhein-Main-Gebiet. *Universitätsforschungen zur prähistorischen Archäologie* 5 (Bonn 1991).
- Hansen 1994**
S. Hansen, Studien zu den Metalldeponierungen während der älteren Urnenfelderzeit zwischen Rhönetal und Karpatenbecken. *Universitätsforschungen zur prähistorischen Archäologie* 21 (Bonn 1994).
- Hansen 1996–1998**
S. Hansen, Migration und Kommunikation während der späten Bronzezeit. Die Depots als Quelle für ihren Nachweis. *Dacia N.S.* 40–42, 1996–1998 (2000), 5–28.
- Hansen 2000**
S. Hansen, Gewässerfunde im bronzezeitlichen Europa. Ein Panorama. *Das Altertum* 46, 2000, 31–62.
- Hansen 2002**
S. Hansen, “Überausstattungen” in Gräbern und Horten der Frühbronzezeit. In: J. Müller (ed.), *Vom Endneolithikum zur Frühbronzezeit: Muster sozialen Wandels? Tagung Bamberg 14.–16. Juni 2001* (Bonn 2002) 151–173.
- Hansen 2008**
S. Hansen, Bronzezeitliche Horte als Indikatoren für “andere Orte”. *Das Altertum* 53, 2008, 291–314.
- Hansen 2009**
S. Hansen, Kupferzeitliche Äxte zwischen dem 5. und 3. Jahrtausend in Südosteuropa. *Analele Banatului S. N.* 17, 2009, 129–158.
- Hansen 2011**
S. Hansen, Technische und soziale Innovationen in der zweiten Hälfte des 4. Jahrtausends v. Chr. In: S. Hansen/J. Müller (eds.), *Sozialarchäologische Perspektiven: Gesellschaftlicher Wandel 5000–1500 v. Chr. zwischen Atlantik und Kaukasus. Archäologie in Eurasien* 24 (Main 2011) 153–191.
- Hansen 2012**
S. Hansen, Bronzezeitliche Horte: Zeitliche und räumliche Rekontextualisierungen. In: S. Hansen/D. Neumann/T. Vachta (eds.), *Hort und Raum. Aktuelle Forschungen zu bronzezeitlichen Deponierungen in Mitteleuropa* (Berlin 2012) 23–48.
- Hansen 2013a**
S. Hansen, The birth of the hero. The emergence of a social type in the 4th millennium BC. In: E. Starnini (ed.), *Unconformist Archaeology. Papers in honour of Paolo Biagi* (Oxford 2013) 101–112.
- Hansen 2013b**
S. Hansen, Deponierungen in der Bronzezeit Europas. In: *Catalogue St. Petersburg 2013*, 279–289.
- Hansen 2014**
S. Hansen, Goldene Scheiben aus der Kupferzeit. *Das Altertum* 59, 2014, 81–108.
- Hansen 2016**
S. Hansen, Gabe und Erinnerung – Heiligtum und Opfer. In: S. Hansen/D. Neumann/T. Vachta (eds.), *Raum, Gabe und Erinnerung. Weihgaben und Heiligtümer in prähistorischen und antiken Gesellschaften. Topoi, Berlin Studies of the Ancient World* 38 (Berlin 2016) 211–236.
- Hansen 2017**
S. Hansen, Key Techniques in the Production of Metals in the 6th and 5th Millennia BCE: Prerequisites, Preconditions and Consequences. In: J. Maran/P.W. Stockhammer (eds.), *Appropriating innovations: entangled knowledge in Eurasia 5000–1500 BCE. Papers of the Conference, Heidelberg, 15–17 January 2015* (Oxford 2017) 136–148.
- Hansen 2019**
S. Hansen, Metalldeponierungen in Europa. Ein Phänomen der Langen Dauer, der Konjunkturen und der Ereignisse. In: S. Hye/U. Töchterle (eds.), *UPIKU:TAUKE. Festschrift für Gerhard Tomedi zum 65. Geburtstag* (Bonn 2019) 201–218.
- Hansen 2020**
S. Hansen, Ikonographische Innovationen im Kaukasus: die Löwen im Grab von Majkop / Иконографические нововведения на Кавказе: львы в Майкопском кургане. In: M.T. Kašuba/S. Reinhold/Ju. Ju. Piotrovskij (eds.), *Der Kaukasus zwischen Osteuropa und Vorderem Orient in der Bronze- und Eisenzeit: Dialog der Kulturen, Kultur des Dialoges. Archäologie in Iran und Turan* 19 (Berlin 2020) 173–198.
- Hansen in print**
S. Hansen, Arsenic Bronze. An archaeological introduction into a key innovation. *Eurasia Antiqua* 24, in print.
- Hauptmann et al. 2002**
A. Hauptmann/S. Schmitt-Strecker/F. Bege-mann/A. Palmieri, Chemical Composition and Lead Isotopy of Metal Objects from the “Royal” Tomb and Other Related Finds at Arslantepe, Eastern Anatolia. *Paléorient* 28, 2, 2002, 43–70.
- von Haxthausen 1894**
E. von Haxthausen, Der Kupferfund bei Gross-Heubach a./M., 1892. *Prähistorische Blätter* 6, 1894, 33–39.
- Heidary/Desset/Vidale 2019**
M. Heidary/F. Desset/M. Vidale, A Late 4th–early 3rd millennium BC grave at Spidej (Eastern Jazmurian, Iranian Baluchistan). *Iranica Antiqua* 54, 2019, 17–57.
- Heide 2003**
B. Heide (ed.), *Leben und Sterben in der Steinzeit* (Mainz 2003).
- Helwing 2004**
B. Helwing, Klassifikation, Typologie und Datierung der untersuchten Metallobjekte. In: H. Hauptmann/E. Pernicka (eds.), *Die Metallindustrie in Mesopotamien vol. 1; Orient-Archäologie 3*; unpublished. https://www.academia.edu/2184593/DRAFT_ONLY_Klassifikation_Typologie_und_Datierung_der_untersuchten_Metallobjekte_to_appear_as_2_chapters_in_planned_volume_2_of_H._Hauptmann_E._Pernicka_eds._Die_Metall-industrie_in_Mesopotamien_vol._1_Orient-Archäologie_3_Rahden_2004_ (visited at 31.3.2020).
- Helwing 2017**
B. Helwing, Networks of Craft Production and Material Distribution in the Late Chalcolithic. Metallurgical Evidence from Iran and the Southern Caucasus. In: E. Rova/M. Tonussi (eds.), *At the Northern Frontier of Near Eastern Archaeology. Subartu XXXVIII* (Turnhout 2017) 51–78.
- Heyd/Walker 2014**
V. Heyd/K. Walker, The First Metalwork and Expressions of Social Power. In: C. Fowler/J. Harding/D. Hofmann (eds.), *The Oxford Handbook of Neolithic Europe* (Oxford 2014) 674–691.
- Horn 2014**
Chr. Horn, Studien zu den europäischen Stabdolchen. *Universitätsforschungen zur prähistorischen Archäologie* 246 (Bonn 2014).
- Hubert/Mauss 1968**
H. Hubert/M. Mauss, *Essay sur la nature et la fonction du sacrifice*. In: M. Mauss, *Oeuvres* vol. 1 (Paris 1968) 193–307.
- Ivanova 2016**
M. Ivanova, Stop and go: die Ausbreitung kaukasischer Metallformen in Osteuropa in der ersten Hälfte des 3. Jt. v. Chr. In: V. Nikolov/W. Schier (eds.), *Der Schwarzmeerraum vom Neolithikum bis in die Früheisenzeit (6000–600 v. Chr.)*. Kulturelle Interferenzen in der zirkumpontischen Zone und Kontakte mit

- ihren Nachbargebieten (Rahden/Westf. 2016) 403–416.
- Ivanova/Rassmann 2014**
M. Ivanova/K. Rassmann, Das spätchalkolithische Steinkistengrab von Dolinka, Kr. Krasnoperekopsk, Ukraine. Neue spektralanalytische Untersuchung und absolute Chronologie. *Eurasia Antiqua* 20, 2014, 207–218.
- Japaridze 1961**
O.M. Japaridze, Qartveli tomebis istoriasavis litoris tsarmoebis adeul saphechoris (On the History of Georgian Tribes in the Aeneolithic and Early Bronze Ages) (Tbilisi 1961).
- Japaridze 1991**
O. Japaridze, Saqartvelos arqeologia (qvisa da bridzaos chana) (On the Ethnic-Cultural History of Georgian Tribes in the 3rd Millennium BC) (Tbilisi 1991).
- Japaridze 1998**
O. Japaridze, Kartveli tomebis etno-kulturuli istoriasavis dzv. ts. III atastsleulshi (Adrekhorganuli kultura) (On the Ethnic-Cultural History of Georgian Tribes in the 3rd Millennium BC) (Tbilisi 1998).
- Jeunesse 2014a**
C. Jeunesse, Tumulus et agglomérations géantes dans le Chalcolithique d'Europe orientale (cultures de Maikop et de Tripolje): comment les "sociétés villageoises" chalcolithiques succombent à la démesure. In: R.M. Argobast/A. Greffier-Richard (dir.), *Entre Archéologie et écologie, une Préhistoire de tous les milieux. Mélanges offerts à Pierre Pétrequin* (Besançon 2014) 331–334.
- Jeunesse 2014b**
C. Jeunesse, Emergence of the Ideology of the Warrior in the Western Mediterranean during the second Half of the fourth Millennium BC. *Eurasia Antiqua* 14, 2014 (2017), 171–184.
- Jeunesse 2017**
C. Jeunesse, From Neolithic kings to the Staffordshire hoard. Hoards and aristocratic graves in the European Neolithic: the birth of a 'Barbarian' Europe? In: P. Bickle/V. Cummings/D. Hofmann/J. Pollard (eds.), *The Neolithic of Europe. Papers in Honour of Alasdair Whittle* (Oxford 2017) 175–187.
- Yudin/Kochetkov 2019**
А.И. Юдин/Ю.Е. Кочетков, Майкопское поселение Чекон на Кубани и проблемы культурных. In: Н.Л. Моргунова (ed.), *Феномены культур раннего бронзового века степной и лесостепной полосы Евразии: пути культурного взаимодействия в V—III тыс. до н.э.* (Оренбург 2019) 83–87.
- Kadar 2007**
M. Kadar, *Începuturile și dezvoltarea metalurgiei bronzului în Transilvania* (Alba Iulia 2007).
- Kaiser 2005**
E. Kaiser, Frühbronzezeitliche Gräber von Metallhandwerkern mit Gußformen für Schaftlochhäxte im osteuropäischen Steppenraum. In: B. Horejs/E. Kaiser/R. Jung (eds.), *Interpretationsraum Bronzezeit. Bernhard Hänsel von seinen Schülern gewidmet. Universitätsforschungen zur prähistorischen Archäologie* 121 (Bonn 2005) 265–291.
- Kaiser 2019**
E. Kaiser, Das dritte Jahrtausend im osteuropäischen Steppenraum. *Berlin Studies of the Ancient World* 37 (Berlin 2019).
- Kalmykov/Korenevskii 2001**
А.А. Калмыков/С.Н. Корневский, Новое погребение с бронзовым топором эпохи средней бронзы из степного Предкавказья. In: А.Б. Белинский (ed.), *Материалы по изучению историко-культурного наследия Северного Кавказа vol. 2* (Москва 2001) 52–63.
- Kantorovič/Maslov 2008**
A.R. Kantorovič/V.E. Maslov. Eine reiche Bestattung der Majkop-Kultur im Kurgan nahe der stanica Mar'inskaja, rajon Kirov, kraj. Stavropol'. *Eurasia Antiqua* 14, 2008, 151–165.
- Kantorovich/Maslov 2009**
А.Р. Канторович/В.Е. Маслов, Раскопки погребения майкопского вождя в кургане близ станицы Марьинской (предварительная публикация). In: А.Б. Белинский (ed.), *Материалы по изучению историко-культурного наследия Северного Кавказа. Вып. IX: Археология, краеведение* (Moskau 2009) 83–116.
- Kaufmann 2002**
D. Kaufmann, Kupfer in der Steinzeit. In: H. Meller (ed.), *Schönheit, Macht und Tod. 120 Funde aus 120 Jahren. Landesmuseum für Vorgeschichte Halle (Halle/Saale 2002)* 86–87.
- Kavtaradze 1981**
G. Kavtaradze, Saqartvelos eneolit-brindjaos chanis arqeologiuri kulturebis qronologia achali monatsemebis schuqze (The Chronology of Georgian Aeneolithic-Bronze Age Archaeological Cultures in the Light of New Data) (Tbilisi 1981).
- Kelder 2009**
J.M. Kelder, Royal Gift Exchange between Mycenae and Egypt: Olives as "Greeting Gifts" in the Late Bronze Age Eastern Mediterranean. *American Journal of Archaeology* 113, 2009, 339–352.
- Kleitsas 2019**
Chr. Kleitsas, The Hoard of Rodotopi in Ioannina (Epirus, NW Greece) and the Copper Single-Edged Shaft-Hole Axes of the Early Bronze Age in the Helladic Area. *Archäologischer Anzeiger* 2019, 1–41.
- Klimscha 2016**
F. Klimscha, Pietrele 1: Beile und Äxte aus Stein. Distinktion und Kommunikation während der Kupferzeit im östlichen Balkangebiet. *Archäologie in Eurasien* 34 (Bonn 2016).
- Klochko 2006**
В.И. Клочко, Озброєння та військова справа давнього населення України (Київ 2006).
- Klochko 2012**
В.И. Клочко, Гордіївський феномен» (The Gordeyevka Phenomenon). In: W. Blajer (red.), *Peregrinationes archaeologicae in Asia et Europa. Joanni Chochorowski dedicatae* (Kraków 2012) 395–404.
- Klochko/Klochko 2013**
V. Klochko/L. Klochko, Complex of metal goods between the Vistula and Dnieper rivers at the turn of 4000–3000 to 3000 BC. Concept of the Carpathian-Volhynia "willow leaf" metallurgy centre. *Baltic-Pontic Studies* 18, 2013, 36–68.
- Klochko/Kozymenko 2017**
В.И. Клочко/А.В. Козыменко, Древний металл Украины (Киев 2017).
- Kohl 2007**
Ph.L. Kohl, *The Making of Bronze Age Eurasia* (Cambridge/New York 2007).
- Kohl/Gadzhiev/Magomedov 2002**
Ph.L. Kohl/M.G. Gadzhiev/R.G. Magomedov, Connections between the Caucasus and the West Eurasian Steppes during the 3rd Millennium BC. In: K. Jones-Bley/D.G. Zdanovich (eds.), *Complex Societies of Central Eurasia from the Third to the First Millennia BC: Regional specifics in the light of global models. Journal of Indo-European Studies Monograph Series* 45 (Washington D.C. 2002) 518–546.
- Korenevskii 1974**
С.Н. Корневский, О металлических топорах майкопской культуры. *Советская археология* 1, 1974, 14–32.
- Korenevskii 1981**
С.Н. Корневский, Втульчатые топоры – оружие ближнего боя эпохи средней бронзы Северного Кавказа. In: Б.А. Литвинский (ред.), *Кавказ и Средняя Азия в древности и средневековье. История и культура* (Москва 1981) 20–41.
- Korenevskii 2004**
С.Н. Корневский, Древнейшие земледельцы и скотоводы Предкавказья (Москва 2004).
- Korenevskii 2011**
С.Н. Корневский, Древнейший металл Предкавказья (Москва 2011).
- Korenevskii/Petrenko 1982**
С.Н. Корневский/В.Г. Петренко, Курган майкопской культуры у поселка Иноземцево. *Советская археология* 2, 1982, 96–112.
- Korenevskii/Rezepkin 2008**
С.Н. Корневский/А.Д. Резепкин, Радиоуглеродная хронология памятников круга майкопского кургана и новосвободненских гробниц. *Проблемы истории, филологии, культуры* 22, 2008, 109–127.
- Korenevskii/Rostunov 2004**
С.Н. Корневский/ В.Л. Ростунов, большие курганы майкопской культуры у с. заманкул в Северной осетии. In: А.Н. Гей (ред.), *Памятники археологии и древнего искусства евразии* (Москва 2004) 148–167.
- Korenevskii/Yudin 2019**
С.Н. Корневский/А.И. Юдин, Поселения майкопско-новосвободненской общности Тузла-15 и Чекон: особенности культурного слоя и стратиграфия (предварительное сообщение). In: Н.Л. Моргунова (ed.), *Феномены культур раннего бронзового века степной и лесостепной полосы Евразии: пути культурного взаимодействия в V—III тыс. до н.э.* (Оренбург 2019) 60–69.

- Korenevskii/Berezin/Gabuev 2018**
С.Н. Корневский/Я.Б. Березин/Т.А. Габуев, Уникальное погребение эпохи средней бронзы на Кавминводах. Краткие сообщения Института археологии 252, 2018, 67–86.
- Koridze 1965**
D. Koridze, Kolchuri kulturis istoriisatvis (The History of the Cochis Culture) (Tbilisi 1965).
- Knudtzon 1915**
J.A. Knudtzon (ed.), Die El-Amarna Tafeln (Leipzig 1915).
- Kuzmina 2003**
О.В. Кузьмина, К вопросу о происхождении бронзовых топоров абашевского типа Абашевская культурно-историческая общность: истоки, развитие, наследие. Материалы международной научной конференции. Чебоксары, Россия 26–30 мая 2003 года (Чебоксары 2003) 92–102.
- Kuznetsov 2009**
П.Ф. Кузнецов, Курганные культуры и вероятность миграционных моделей. In: Проблемы изучения культур раннего бронзового века степной зоны Восточной Европы (Оренбург 2009) 98–104.
- Kvirkvaia/Jibladze 2019**
R. Kvirkvaia/L. Jibladze, Litonis artefaqtebi sofel Zeda ilemidan (Metal Artifacts from Village Zeda Ilemi). Online Archaeology 15, 2019, 50–62. <https://www.heritagesites.ge/uploads/files/5d5e72c46ec92.pdf?fbclid=IwAR1EijwU3Qtz6U-6H0ce1RgVultiQ46BCJerr3SGOfhAn4dq0pfbwK0JwPU>
- Kvitsiani/Jibladze 2015**
Z. Kvitsiani/L. Jibladze, Uachlesi arqeologiuri aghmochenbi svanetschi (The Latest Archaeological Discoveries in Svaneti) (Tbilisi 2015).
- Lechtman 1996**
H. Lechtman, Arsenic Bronze: Dirty Copper or Chosen Alloy? A View from the Americas. Journal of Field Archaeology 23, 1996, 477–514.
- Lichter 2018**
C. Lichter, Frühbronzezeitliche Eliten in Anatolien im Licht der Gräber. In: Ü. Yalçın (ed.), Anatolian Metal VIII: Eliten – Handwerk – Prestigegüter. Der Anschnitt, Beiheft 39 (Bochum 2018) 77–90.
- Machnik/Tkaczuk 2003**
J. Machnik/T.K. Tkaczuk, Interesting and important artifacts from the beginning of the Bronze Age in the vicinity of Halicz (upper basin of the Dnestr River). In: E. Jerem/P. Raczky (eds.), Morgenrot der Kulturen. Frühe Etappen der Menschheitsgeschichte in Mittel- und Südosteuropa. Festschrift für Nándor Kalicz zum 75. Geburtstag (Budapest 2003) 483–496.
- Mallowan 1947**
M.E.L. Mallowan, Excavations at Brak and Chagar Bazar. Iraq 9, 1947, 1–259.
- Maran 1987**
J. Maran, Die Silbergefäße von el-Töd und die Schachtgräberzeit auf dem griechischen Festland. Prähistorische Zeitschrift 62, 1987, 221–227.
- Maran 2001**
J. Maran, Der Depotfund von Petralona (Nordgriechenland) und der Symbolgehalt von Waffen in der ersten Hälfte des 3. Jahrtausends v. Chr. zwischen Karpatenbecken und Ägäis. In: R.M. Boehmer/J. Maran (eds.), Lux Orientis. Archäologie zwischen Asien und Europa. Festschrift für Harald Hauptmann (Rahden/Westf. 2001) 275–284.
- Marro/Bakhshaliyev/Ashurov. 2011**
C. Marro/V. Bakhshaliyev/S. Ashurov, Excavations at Ovçular Tepesi (Nakhchivan, Azerbaijan). Second Preliminary Report. The 2009–2010 Seasons. Anatolia Antiqua 19, 2011, 53–100.
- Marx 1844/1968**
K. Marx, Ökonomisch-philosophische Manuskripte aus dem Jahre 1844. Marx-Engels-Werke 40 (Ost-Berlin 1968) 465–590.
- Mauss 1968**
M. Mauss, Die Gabe (Frankfurt a. M. 1968).
- Mauss 2012**
M. Mauss, Schriften zur Religionssoziologie (Berlin 2012).
- McMahon/Sołtysiak/Weber 2011**
A. McMahon/A. Sołtysiak/J. Weber, Late Chalcolithic mass graves at Tell Brak, Syria, and violent conflict during the growth of early city-states. Journal of Field Archaeology 36, 2011, 201–220.
- Michailov 2008**
Ф. Михайлов, Нови данни за най-ранния добив и обработка на мед в Долината на Горна Струма. Phosphorion. Studia in honorem Mariae Čičikova (Sofia 2008) 35–47.
- Mildenberger 1950**
G. Mildenberger, Zwei kupferzeitliche Schafthalsäxte aus Mitteldeutschland. Jahresschrift für Mitteldeutsche Vorgeschichte 34, 1950, 27–31.
- Montelius 1903**
O. Montelius, Die typologische Methode (Stockholm 1903).
- Morgunova 2014**
Н.Л. Моргунова, Приуральская группа памятников в системе волжско-уральского варианта ямной культурно-исторической области (Оренбург 2014).
- Morgunova/van der Plicht 2013**
Н.Л. Моргунова/Й. ван дер Плихт, Результаты радиоуглеродного датирования тamar-уткульских курганов в Оренбургской области. Известия Самарского научного центра Российской академии наук, 15, 5, 2013, 261–268.
- Morris 1987**
I. Morris, Burial and ancient society. The rise of Greek city state (Cambridge 1987).
- Müller 2012**
J. Müller, Aspenstedt-Großer Berg: Ein spätneolithisches Grab mit kupfernem Nietdolch – Hinweis auf eine “verpasste Innovation”. Prähistorische Zeitschrift 87, 2012, 44–57.
- Müller 2013**
J. Müller, Missed Innovation: The Earliest Copper Daggers in Northern Central Europe and Southern Scandinavia. In: In: S. Bergerbrant/S. Sabatini (eds.), Counterpoint: Essays in Archaeology and Heritage Studies in Honour of Professor Kristian Kristiansen (Oxford 2013) 443–448.
- Müller et al. 2016**
J. Müller/R. Hoffmann/L. Brandstätter/R. Ohlrau/M. Videiko, Chronology and Demography: How Many People Lived in a Mega-Site? In: J. Müller/K. Rassmann/M. Videiko (eds.), Trypillia Mega-Sites and European Prehistory 4100–3400 BCE (Oxford 2016) 133–170.
- Müller-Karpe 2002**
M. Müller-Karpe, Zur Metallverwendung im Mesopotamien des 4. und 3. Jahrtausends. In: Ü. Yalçın (ed.), Anatolian Metal II. Der Anschnitt, Beiheft 15 (Bochum 2002) 137–148.
- Müseibli/Axundova/Ağalarzade 2012**
N.Ə. Müseyibli/G.K. Axundova/A.M. Ağalarzade, Ağstafa rayonda tunc dövrünün, Qəbir Abidəəri (Ağstafa rayonu) (Burial monuments of the Bronze Age of Ağstafa region). Azərbaycanca Arxeoloji Tədqiqatlar 2011 (Baku 2012) 97–108.
- Munchaev 1975**
Р.М. Мунчаев, Кавказ на заре бронзового века: неолит, энеолит, ранняя бронза. (Москва 1975).
- Munchaev 1994**
Р.М. Мунчаев, Майкопская культура. In: Эпоха бронзы и Северного Кавказа. Археология СССР (Москва 1994) 158–225.
- Munteanu/Costache 2016**
R. Munteanu/D. Costache, Un depozit de obiecte de cupru descoperit la Dobrileşti, jud. Buzău. Studii și Cercetări de Istorie Veche și Arheologie 67, 2016, 105–115.
- Muscarella 1971**
O.W. Muscarella, The Tumuli at Sé Girdan: Second Report. Metropolitan Museum Journal 4, 1971, 5–28.
- Muschalla 2018**
R. Muschalla (ed.), Sparen. Geschichte einer deutschen Tugend (Berlin 2018).
- Nakassis/Galaty/Parkinson 2016**
D. Nakassis/M.L. Galaty/W.A. Parkinson, Discussion and Debate: Reciprocity in Aegean Palatial Societies: Gifts, Debt, and the Foundations of Economic Exchange. Introduction. Journal of Mediterranean Archaeology 29, 2016, 61–70.
- Nebelsick/Lyszkowicz 2018**
L.D. Nebelsick/G. Lyszkowicz, Copper artefact deposits in waters and wetlands during the later 5th and 4th millennium BC in the territory of Poland. In: L.D. Nebelsick/J. Wawrzyniuk/K. Zeman-Wiśniewska (eds.), Sacred space: contributions to the archaeology of belief (Warsaw 2018) 33–64.
- Nechitaïlo 1991**
А.Л. Нечитайло, Связи населения степной Украины и Северного Кавказа в эпоху бронзы (Киев 1991).
- Neumann 2015**
D. Neumann, Landschaften der Ritualisierung: die Fundplätze kupfer- und bronzezeitlicher Metalldeponierungen zwischen Donau und Po. TOPOI – Berlin Studies of the Ancient World 26 (Berlin 2015).

- O'Connor 2004**
B. O'Connor, The earliest Scottish metalwork since Coles. In: I.A.G. Shepherd/G.J. Barclay (eds.), *Scotland in Ancient Europe: the Neolithic and Early Bronze Age of Scotland* (Edinburgh 2004) 205–216.
- Orjonikidze 2015**
A. Orjonikidze, *Adreuli korganbi saqartveloschi* (The Earlier Period Kurgans in Georgia) (Tbilisi 2015).
- Palumbi 2012**
G. Palumbi, The Arslantepe Royal Tomb and the “Manipulation” of the Kurgan Ideology in Eastern Anatolia at the Beginning of the Third Millennium. In: E. Borgna/S. Müller Celka (eds.), *Ancestral Landscapes. Central and Eastern Europe, Balkans, Adriatic, Aegean, 4th–2nd millennium B.C.* Proceedings of the international conference held in Udine, may 15th–18th 2008 (Lyon 2012) 47–59.
- Palumbi et al. 2017**
G. Palumbi/C. Alvaro/C. Grifoni/M. Frangipane, A ‘communal’ building of the beginning of the Early Bronze Age at Arslantepe-Malatya (Turkey). Spatio-functional analysis and interpretation of the archaeological context. *Paléorient* 43, 2017, 89–123.
- Parović-Pešika/Trbuhović 1971**
M. Parović-Pešikan/V. Trbuhović, *Iskopavanja tumula ranog bronzanog doba u Tivatskom polju / Fouilles de tumulus de l'âge du Bronze ancien dans la plaine de Tivat*. *Starinar* 22, 1971, 129–144.
- Pearce 2007**
M. Pearce, *Bright Blades and Red Metal. Essays on north Italian prehistoric metalwork* (London 2007).
- Pétrequin et al. 2012**
P. Pétrequin/S. Cassen/M. Errera/L. Klassen/A. Sheridan/A.M. Pétrequin (eds.), *Jade. Grandes haches alpines du Néolithique européen Ve et IVe millénaires av. J.-C.*, vols. 1–2 (Besançon 2012).
- Pétrequin et al. 2015**
P. Pétrequin/ M. Errera/R. Furestier/F. Prodec, *Quatre grandes lames polies en jades alpins découvertes en Ardèche, fin du Ve millénaire-début du IVe av. J.-C.* *Ardèche Archéologie* 32, 2015, 23–29.
- Piggott 1950**
S. Piggott, *Prehistoric India to 1000 B.C.* (Harmondsworth 1950).
- Pinch/Waraksa 2009**
G. Pinch/E.A. Waraksa, *Votive Practices*. In: J. Dieleman/W. Wendrich (eds.), *UCLA Encyclopedia of Egyptology* (Los Angeles 2009).
- Piotrovskij 2020**
Ju. Ju. Piotrovskij, *Der Majkop-Kurgan (ošad): Vom archäologischen Denkmal zur archäologischen Quelle*. In: M.T. Kašuba/S. Reinhold/Ju. Ju. Piotrovskij (eds.), *Der Kaukasus zwischen Osteuropa und Vorderem Orient in der Bronze- und Eisenzeit: Dialog der Kulturen, Kultur des Dialoges*. *Archäologie in Iran und Turan* 19 (Berlin 2020) 105–172.
- Pkhakadze 1993**
G. Pkhakadze, *Dasavlet amierkavkasia dzveli tselataagritschvis III atatsleuschi* (The western Transcaucasus in the III millennium BC) (Tbilisi 1993).
- Pop 2007**
D. Pop, *The Copper Axe from Corni*. *A Nyíregyházi Jósa András Múzeum Évkönyve* 69, 2007, 49–87.
- Popova 1963**
Т.Б. Попова, *Долмены станицы Новосвободной* (Москва 1963).
- Preda 2015**
B. Preda, Considerations regarding barrow burials and metal depositions during the Early Bronze Age in the Carpathian-Danube Area. *Hiperborea Journal* 2, 2015, 5–51.
- Preda/Frînculeasa 2015**
B. Preda/A. Frînculeasa, *Un topor cu gaură transversală de înmănuș are descoperit la Călugăreni* (jud. Prahova). *Studii și Cercetări de Istorie Veche și Arheologie* 67, 2016, 125–138.
- Primas 1996**
M. Primas, *Velika Gruda I. Hügelgräber des frühen 3. Jahrtausends v. Chr. im Adriagebiet – Velika Gruda, Mala Gruda und ihr Kontext* (Bonn 1996).
- Pulszky 1884**
F. Pulszky, *Die Kupferzeit in Ungarn* (Budapest 1884).
- Quibell/Green 1902**
J.F. Quibell/F.W. Green, *Hierakonpolis II* (London 1902).
- Radwan 1983**
A. Radwan, *Die Kupfer- und Bronzegefäße Ägyptens (Von den Anfängen bis zum Beginn der Spätzeit)* (München 1983).
- Ravich/Ryndina 1995**
I.G. Ravich/N.V. Ryndina, *Early Copper-Arsenic Alloys and the Problems of their Use in the Bronze Age of the North Caucasus*. *Bulletin of the Metals Museum* 23, 1995, 1–18.
- Rech 1979**
M. Rech, *Studien zu Depotfunden der Trichterbecher- und Einzelgrabkultur des Nordens* (Neumünster 1979).
- Reim 2009**
H. Reim, *Die “Eremitage” bei Inzigkofen, Kr. Sigmaringen (Baden-Württemberg). Zur Archäologie eines naturheiligen Platzes an der oberen Donau*. In: J.M. Bagley/C. Eggel/D. Neumann/M. Scheffzik (eds.), *Alpen, Kult und Eisenzeit. Festschrift für Amei Lang zum 65. Geburtstag* (Rahden/Westf. 2009) 161–175.
- Reinhold 2005**
S. Reinhold, *Vom Ende Europas? Zu den Depotfunden im Kaukasus*. In: B. Horejs/E. Kaiser/R. Jung (eds.), *Interpretationsraum Bronzezeit. Bernhard Hänsel von seinen Schülern gewidmet. Universitätsforschungen zur prähistorischen Archäologie* 121 (Bonn 2005) 345–373.
- Rezepkin 2000**
A.D. Rezepkin, *Das frühbronzezeitliche Gräberfeld von Klady und die Majkop-Kultur in Nordwestkaukasien*. *Archäologie in Eurasien* 10 (Rahden/Westf. 2000).
- Rezepkin 2012**
А.Д. Резепкин, *Новосвободненская Культура* (Санкт-Петербург 2012).
- Richlý 1896**
H. Richlý, *Handwerkzeuge eines reisenden Schmiedes der Bronzezeit in Böhmen*. *Mitteilungen der K.K. Zentral-Kommission für Erforschung und Erhaltung Kunst- und Historischen Denkmale NF* 22, 1896, 121–123.
- Rișcuța 2016**
C.N. Rișcuța, *A Copper Axe Discovered in Hărău* (Hunedoara County). In: C.I. Popa, *The Carpathian Basin and the Northern Balkans between 3500 and 2500 BC: Common Aspects and Regional Differences*. *Annales Universitatis Apulensis, Series Historica* 20/II (Alba Iulia 2016) 381–398.
- Ryndina/Ravich 2019**
Н.В. Рындина/И.Г. Равич, *Металл майкопской культуры Северного Кавказа в свете аналитических исследований* (Москва 2019).
- Sağlamtimur/Massimino 2018**
H. Sağlamtimur/M.G.M. Massimino, *Wealth Sacrifice and Legitimacy: The Case of the Early Bronze Age Başur Höyük Cemetery (South-eastern Turkey)*. *Proceedings of the 10th International Congress on the Archaeology of the Ancient Near East 25–29 April 2016, Vienna, vol. 1* (Wiesbaden 2018) 329–342.
- Sava 2015**
V. Sava, *Neolithic and Eneolithic in the Lower Mureș Basin* (Cluj-Napoca 2015).
- Saveljić-Bulatović/Guștin/Hincak 2015**
L. Saveljić-Bulatović/M. Guștin/Z. Hincak, *Podgorica praistorijske humke i srednjovjekovne nekropole Gruda Boljevice* (Podgorica 2015).
- Scholz 2012**
H. Scholz, *Lageuntersuchungen als Mittel zur Hortbeschreibung und -interpretation. Lageverhältnisse bronzezeitlicher Horte in Mecklenburg-Vorpommern*. In: S. Hansen/D. Neumann/T. Vachta (eds.), *Hort und Raum. Aktuelle Forschungen zu bronzezeitlichen Deponierungen in Mitteleuropa* (Berlin 2012) 69–92.
- Schrakamp 2015**
I. Schrakamp, *Militär und Kriegführung in Vorderasien*. In: H. Meller/M. Scheffzik (eds.), *Krieg – Eine archäologische Spurensuche. Begleitband zur Sonderausstellung vom 6. November 2015 bis 22. Mai 2016 im Landesmuseum für Vorgeschichte Halle (Halle [Saale] 2015) 213–224.*
- Schumacher 1903**
K. Schumacher, *Die bronzezeitlichen Depotfunde Südwestdeutschlands*. *Correspondenzblatt der Deutschen anthropologischen Gesellschaft* 10, 1903, 90–101.
- Schunke 2013**
T. Schunke, *Klady-Göhlitzsch. Vom Kaukasus nach Mitteldeutschland oder umgekehrt?* In: H. Meller (ed.), *3300 BC. Mysteriöse Steinzeit-tote und ihre Welt* (Halle/Saale 2013) 151–155.

- Seger 1936**
H. Seger, Schlesische Hortfunde aus der Bronze- und frühen Eisenzeit. *Altschlesien* 6, 1936, 85–201.
- Sergeev 1963**
Г.П. Сергеев, Раннетрипольский клад у с. Карбуна. *Советская археология* 1963, 1, 135–151.
- Sinyuk 1983**
А.Т. Синюк, Курганы эпохи бронзы Среднего Дона (Павловский могильник) (Воронеж 1983).
- Šiška 1972**
S. Šiška, Gräberfelder der Lažňany-Gruppe in der Slowakei. *Slovenská Archeológia* 20, 1972, 107–175.
- Šljivar/Kuzmanović-Cvetković/Jacanović 2006**
D. Šljivar/J. Kuzmanović-Cvetković/D. Jacanović, Belovode – Pločnik, new contributions regarding the copper metallurgy in the Vinča culture. In: N. Tasić/C. Grozdanov (eds.), *Homage to Milutin Garašanin* (Belgrade 2006) 251–266.
- Šljivar/Kuzmanović-Cvetković/Živković 2011**
D. Šljivar/J. Kuzmanović-Cvetković/J.D. Živković, Belovode, Pločnik; on Copper Metallurgy in the Vinča Culture. *Zbornik narodnog muzeja Beograd* 22, 2011, 27–45.
- Sørensen/Bjørnevad/Bye-Jensen 2020**
C. Sørensen/M. Bjørnevad/P. Bye-Jensen, A biographical study of Neolithic hoarding. A regional case study of Funnel Beaker Culture hoards from the Southern Limfjord area, Denmark. *Danish Journal of Archaeology* 9, 2020, 1–24.
- Sombart 1996**
W. Sombart, *Liebe, Luxus und Kapitalismus: Über die Entstehung der modernen Welt aus dem Geist der Verschwendung* (Berlin 1996).
- Soroceanu 2012**
T. Soroceanu, Die Kupfer- und Bronzebeds der frühen und mittleren Bronzezeit in Rumänien. *Archaeologia Romanica* 5 (Cluj-Napoca 2012).
- Stalio 1964**
Б. Сталио, Нови метални налаз из Плочника код Прокупља. *Зборник народног музеја Београд* 4, 1966, 35–41.
- Stalio 1973**
Б. Сталио, Четврти налаз и каменог оруђа са Плочника код Прокупља. *Зборник народног музеја Београд* 7, 1973, 157–161.
- Ștefan 2007**
C.-E. Ștefan, Un topor din cupru aflat în colecțiile Muzeului Național de Antichități / Une hache de cuivre inédite dans les collections du Musée National des Antiquités de Bucharest. *Materiale și cercetări arheologice. Serie nouă* 3, 2007, 83–87.
- Stein 1931**
A. Stein, An Archaeological Tour in Gedrosia. *Memoirs of the Archaeological Survey of India* 43 (Calcutta 1931).
- Stein 2012**
G.J. Stein, The Development of Indigenous Social Complexity in Late Chalcolithic Upper Mesopotamia in the 5th–4th Millennia BC – An Initial Assessment. *Origini* 34, 2012, 125–151.
- Stöllner et al. 2006**
T. Stöllner/J. Cierny/C. Eibner/N. Boenke/R. Herd/A. Maass/K. Röttger/T. Sormaz/G. Steffens/P. Thomas, Der bronzezeitliche Bergbau im Südevier des Mitterberggebietes. Bericht zu den Forschungen der Jahre 2002 bis 2006. *Archaeologia Austriaca* 90, 2006, 87–137.
- Szeverényi 2013**
V. Szeverényi, The Earliest Copper Shaft-Hole Axes in the Carpathian Basin: Interaction, Chronology and Transformations of Meaning. In: A. Anders/G. Kulcsár (eds.), *Moments in Time. Papers Presented to Pál Raczky on His 60th Birthday* (Budapest 2013) 661–669.
- Tadmor et al. 1995**
M. Tadmor/D. Kedem/F. Begemann/A. Hauptmann/E. Pernicka/S. Schmitt-Strecker, The Nahal Mishmar Hoard From the Judean Desert: Technology, Composition, and Provenance. *Atiqot* 27, 1995, 95–148.
- Tallgren 1928**
A.M. Tallgren, s. v. Staromyšastovskaja. In: M. Ebert, *Reallexikon der Vorgeschichte* 12 (Berlin 1928) 389.
- Tallon 1987**
F. Tallon, Métallurgie susienne I. De la fondation de Suse au XVIIIe siècle avant J.-C., vol. 1–2 (Paris 1987).
- Tchabashvili/Bastert-Lamprichs/Giemsch 2018**
L. Tchabashvili/ K. Bastert-Lamprichs/ L. Giemsch, Objekte der Ausstellung. In: L. Giemsch/S. Hansen (eds.), *Gold & Wein. Georgiens älteste Schätze. Begleitband zur Sonderausstellung 6. Oktober 2018–10. Februar 2019*, Archäologisches Museum Frankfurt (Mainz 2018) 257–353.
- Torbrügge 1970–1971**
W. Torbrügge, Vor- und frühgeschichtliche Flußfunde. Zur Ordnung und Bestimmung einer Denkmälergruppe. Bericht der Römisch-Germanischen Kommission 50–51, 1970–1971, 1–146.
- Trifonov et al. 2017**
В.А. Трифонов/Н.И. Шишлина/Й. ван дер Плихт/Р. Фернандес/П. Хоммель, Радиоуглеродная хронология дольменов эпохи бронзы у ст. Царская, северо-западный Кавказ, 1898 г. In: А.А. Тишкин (ред.), *V (XXI) Всероссийский археологический съезд, сборник научных трудов*, 2017, Алтайский государственный университет (Барнаул 2017) 1042–1043.
- Trifonov et al. 2018**
В.А. Трифонов/Н.И. Шишлина/О.Ф. Чернова/ В.С. Севастьянов/Й. ван дер Плихт/Ф.Н. Голенищев, Шуба” эпохи ранней бронзы из дольмена у станицы царская (1898 г.) на северо-западном кавказе: методика и результаты комплексного исследования. *Российская археология* 2018, 1, 118–134.
- Truhelka 1909a**
C. Truhelka, Kupferfund von Griča (Bezirk Varcar Vakuf). *Wissenschaftliche Mitteilungen aus Bosnien und der Herzegovina* 11, 1909, 43–50.
- Truhelka 1909b**
C. Truhelka, Kupferfund von Kozarac. *Wissenschaftliche Mitteilungen aus Bosnien und der Herzegovina* 11, 1909, 54–55.
- Ursachi 2012:**
V. Ursachi, Tezaurul eneolitic de la Brad (București 2012).
- Vachta 2016**
T. Vachta, Bronzezeitliche Hortfunde und ihre Fundorte in Böhmen. *Berlin Studies of the Ancient World* 33 (Berlin 2016).
- Veblen 1994**
T. Veblen, *The Theory of the Leisure Class* (New York 1994; original 1899).
- Vetrosov/Nagoev 1984**
Р.Ж. Бетрозов/А.Х. Нароев, Курганы эпохи бронзы у селений Черем-1, Черем-2 и Кишпек. In: В.И. Марковин (ред.), *археологические исследования на новостройках Кабардино-Балкарии 1* (Нальчик 1984) 7–87.
- Vladár 1970**
J. Vladár, K otázke chronologického postavenia medených sekeriek s Jedným Ostrím / Zur Frage der chronologischen Stellung der kupfernen Schaftalsäxte. *Študijné Zvesti Archeologického Ústavu* 18, 1970, 5–18.
- Vulpe 1970**
A. Vulpe, Die Äxte und Beile in Rumänien I. *Prähistorische Bronzefunde IX, 5* (München 1970).
- Wang et al. 2019**
C.-C. Wang/S. Reinhold/A. Kalmykov/A. Wissgott/G. Brandt/C. Jeong/O. Cheronet/M. Ferry/E. Harney/D. Keating/S. Mallick/N. Rohland/K. Stewardson/A.R. Kantorovich/V.E. Maslov/V.G. Petrenko/V.R. Erlikh/B.Ch. Atabiev/R.G. Magomedov/P.L. Kohl/K.W. Alt/S.L. Pichler/C. Gerling/H. Meller/B. Vardanyan/L. Yeganyan/A.D. Rezepkin/D. Mariaschk/N. Berezina/J. Gresky/K. Fuchs/C. Knipper/S. Schiffels/E. Balanovska/O. Balanovsky/I. Mathieson/T. Higham/Y.B. Berezina/A. Buzhilova/V. Trifonov/R. Pinhasi/A.B. Belinskij/D. Reich/S. Hansen/J. Krause/W. Haak, Ancient human genome-wide data from a 3000-year interval in the Caucasus corresponds with eco-geographic regions. *Nature communications* 10: 590 (2019). <https://doi.org/10.1038/s41467-018-08220-8>
- Wegner 1976**
G. Wegner, Die vorgeschichtlichen Flußfunde aus dem Main und dem Rhein bei Mainz (Kallmünz/Opf. 1976).
- Wengrow 2011**
D. Wengrow, ‘Archival’ and ‘Sacrificial’ Economies in Bronze Age Eurasia: an Interactionist Approach to the Hoarding of Metals. In: T.C. Wilkinson/S. Sherratt/J. Bennet (eds.), *Interweaving worlds. Systemic interactions in Eurasia, 7th to 1st Millennia BC*. Papers from a conference in memory of Professor Andrew Sherratt (Oxford 2011) 135–144.
- Wentink 2006**
K. Wentink, Ceci n'est pas une hache. Neolithic Depositions in the Northern Netherlands (Leiden 2006).

Windholz-Konrad 2003

M. Windholz-Konrad, *Funde entlang der Traun zwischen Ödensee und Hallstätter See* (Wien 2003).

Windholz-Konrad 2005

M. Windholz-Konrad, *Der spätbronzezeitliche Deponierungsplatz bei der Rabenwand im steirischen Salzkammergut, Österreich*. *Das Altertum* 50, 2005, 255–301.

Winghart 1986

S. Winghart, *Vorgeschichtliche Deponate im ostbayerischen Grenzgebirge und im Schwarzwald*. *Zu Horten und Einzelfunden in den Mittelgebirgslandschaften*. *Berichte der Römisch-Germanischen Kommission* 67, 1986, 90–201.

Wirth 2000

St. Wirth, *Die Funde aus der Donauschleife bei Schäfstall in Bayern*. In: L. Bonnamour (ed.), *Archéologie des fleuves et des rivières* (Paris 2000) 84–92.

Woolley 1934

L. Woolley, *Ur Excavations II. The Royal Cemetery* (London/Philadelphia 1934).

Woolley 1952

L. Woolley, *Report on the Excavations at Jerablus on Behalf of the the British Museum, Part III: The Excavations in the Inner Town* (London 1952).

Worsaae 1866

J.J.A. Worsaae, *Om nogle mosefund fra Bron-*

cealderen. *Aarbøger for Nordisk Oldkyndighed og Historie* 1866, 313–326.

Yates/Bradley 2010

D. Yates/R. Bradley, *The Siting of Metalworking Hoards in the Bronze Age of South-East England*. *The Antiquaries Journal* 90, 2010, 41–72.

Photo Credits

1 after Pulszky 1884; **2** after Bar-Adon 1980; **3** after Stalio 1973; **4** photo ©Landesmuseum Mainz; **5** after Baudouin 1923; **7** after Bisson de la Roque/Contenau/Chapouthier 1953; **6** modified after Bianchin Citton 2013; **8–9** after Dunand 1950; **10** after Woolley 1934; **11** after Mikhailov 2008; **12** after Hansen 2009; **13** after Ursachi 2012; **14** after Dergachev 2018; **15** after Marro/Bakhshaliyev/Ashurov 2011; **16** after Munteanu/Costache 2016; **17** after Dergachev 2018; **18** after Klochko/Kozymenko 2017; **19** after Tallgren 1928; **20** after Chernykh 1992; **21** after Korenevskii 2011, Pl. 48,4; **22** after Batchaev/Korenevskii 1980; **23** after Hansen 2020; **24** after Korenevskii 2004; **25** after Casal 1961, 249, Pl. 39B; **26** according to Korenevskii/Rostunov 2004; **27** photo S. Hansen; **28** after Vetrosov/Nagoev 1984, 27; 42, Fig. 10,2.7.10.11; 45, Fig. 11,1; 47, Fig. 13,3–8; **29** after Chechenov 1984, 165–173, Fig. 9; **30** after Korenevskii/

Petrenko 1982; **31** after Kantorovič/Maslov 2008; **32** after Munchaev 1975, 257–259, Fig. 57; **33** after Gimbutas 1956; **34** after Rezepkin 2000, altered; **35** according to Rezepkin 2000, 59–61, Pls. 46–47; **36** according to Rezepkin 2000; **37** after Ivanova/Rassmann 2014; **38** after Klochko/Klochko 2013, 50, Fig. 8; **39** after Soroceanu 2012, modified; **40** detail Josephinian map; **41** after Hampel 1903; **42** after Rîșcuța 2016; **43** after Benešová 1956; **44** after Munchaev 1994, 206, Fig. 54; **45** after Vladár 1970; **46** after Mildenerger 1950; **47** after Popova 1963; **48** graph by M. Karaucak; **49** after Govedarica 2019; **50** after Adamczak *et al.* 2015; **51** after Behm-Blancke 1984; **52** photo ©Museum Kotor; **53** after Truhelka 1909b; **54** after Kleitsas 2019; **55** after Preda/Frînculeasa 2015; **56** after Bratchenko/Klochko/Soltis 2000; **57** after Morgunova 2014, 192, Fig. 94; **58** after Kalmykov/Korenevskii 2001; **59** after Kohl/Gadzhiev/Magomedov 2002, 536–539, Fig. 11; **60–62** photos ©N. Kopaliani; **63** after Müseyibli/Axundova/Ağalarzadə 2012, modified; **64** courtesy of the Georgian National Museum Tbilisi, photo by S. Hansen; **65** after Korenevskii/Berezin/Gabuev 2018, Fig. 6,4; **66** after Kvitsiani/Jibladze 2015, 120, Pl. 3,2–3; **67** after Ailincăi 2005; **68** after Machnik/Tkaczuk 2003; **69** after Antoniewicz 1929; **70** after Korenevskii 1974, modified; **71–72** after Koridze 1965, Pls. 1–2; 3,2–7; **73** map by M. Karaucak.